

THE RADIO EXPERIMENTER'S MAGAZINE

HUGO GERNSBACK
Editor

SHORT WAVE AND TELEVISION

August

WORLD'S
LARGEST
SHORT WAVE
CIRCULATION

Lighting Lamp
by S-W Radio

See Page 166

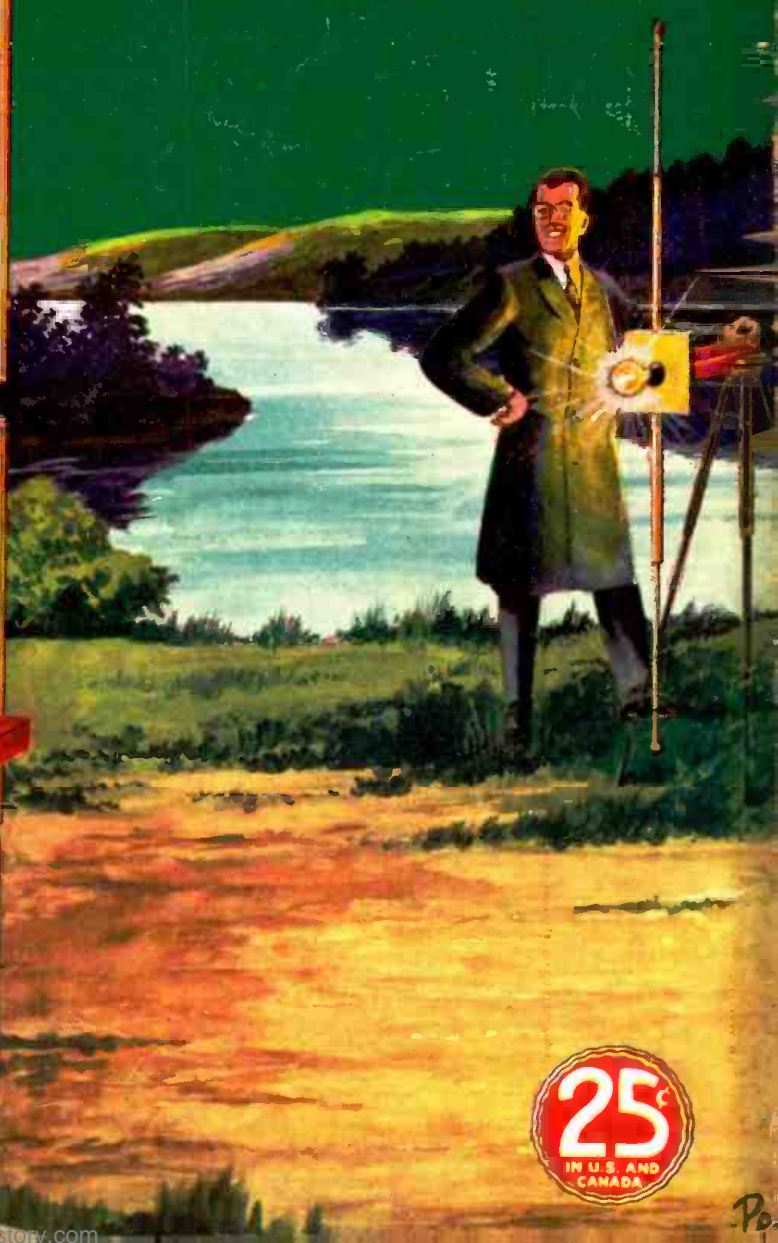
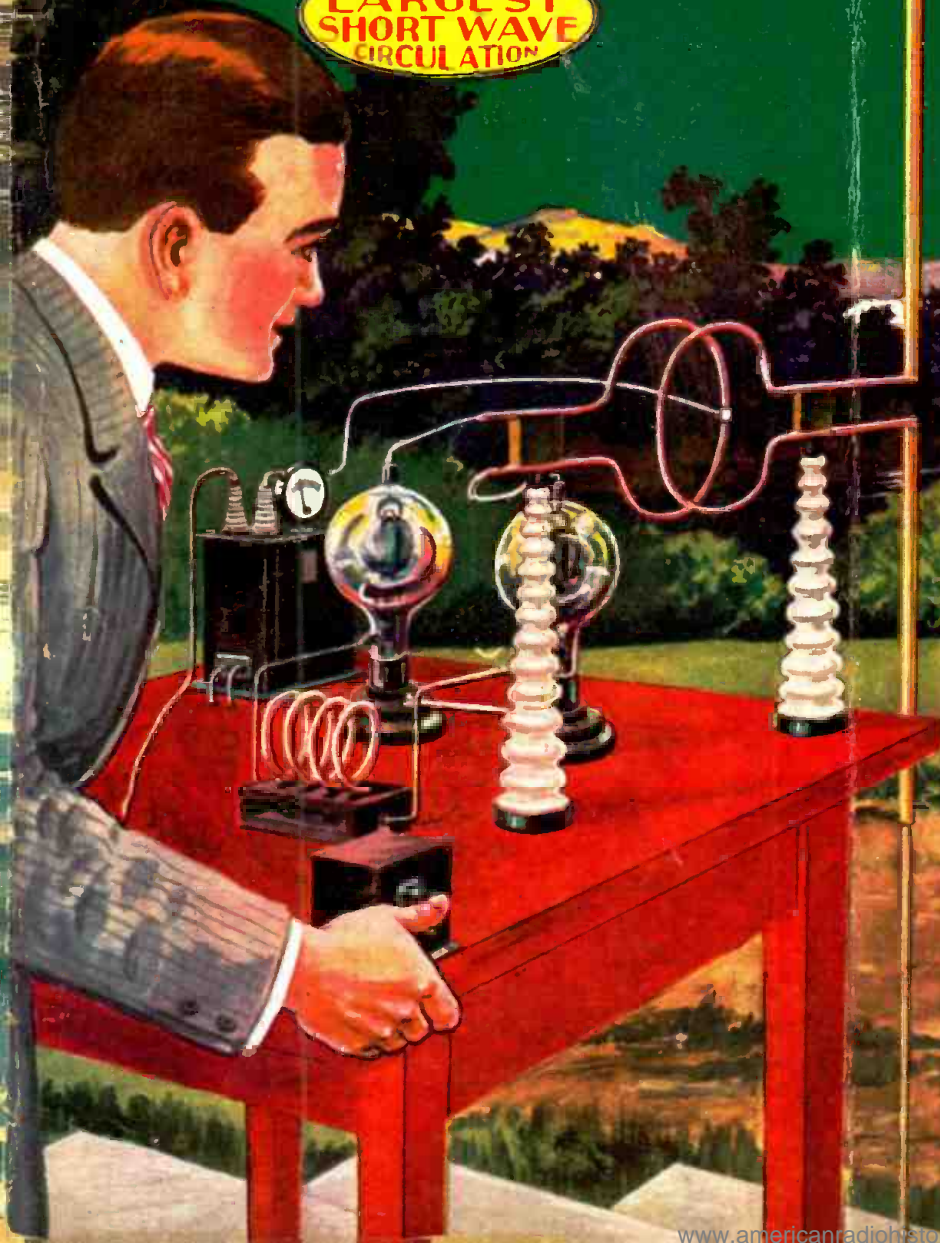

25¢
IN U.S. AND
CANADA

The ULTIMATE in U.H.F. PRODUCTS

ULTRA DUPLEX 5 TUBE BATTERY PORTABLE 2 1/2 to 5 Meters (56 to 120 M.C.)

NEW TUBES, NEW CIRCUIT, the ideal complete station for portable use. Receiver and transmitter absolutely independent of each other. Receiver uses 1-19, 1-1F5G, as detector, 1st and 2nd stage of A.F. Transmitter uses 1-19, oscillator, 1-1E5G speech amplifier, 1-1E7G class A modulator. Past proven performance together with the addition of several up to the minute features insures superb results. Separate antennas are used for receiver and transmitter to obtain the peak of efficiency for both units regardless of frequency settings. Supplied complete with all coils including coil for 10 meter reception.

- 19-1F5G-19-1E5G-1E7G
- Built in Wright DeCoster Nokoil Speaker
- Extremely low current drain
- 100% class A plate modulation
- Negligible receiver radiation
- Receiver or transmitter may be turned off when not in use
- Great usable sensitivity
- Automatic phone jack

Complete with built in Nokoil speaker and cabinet with battery compartment, wired and tested, less tubes, batteries, microphone and antenna **\$20.95**

Set of 5 Sylvania tube **\$4.62**
American SB hand mike **2.95**
Adjustable 8 ft. antenna **1.60**

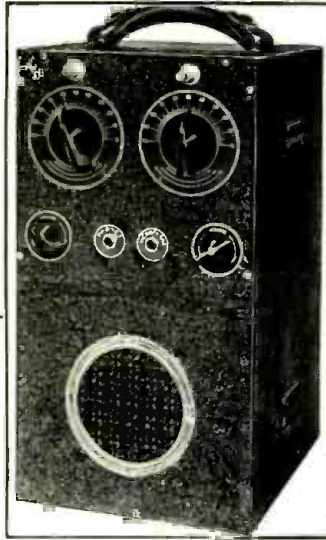

ULTRA DUPLEX 6 TUBE MOBILE OR A.C. 2 1/2 to 5 Meters (56 to 120 M.C.)

This unit uses six of the latest 6 volt tubes in a circuit which may be operated from a 6 volt automobile battery or by substituting power supplies from 110 volts A.C. Receiver uses 1-6J5G as a supersensitive detector, 1-6J7 1st A.F. stage, 1-6F6 output stage. Transmitter consists of 1-6E6 oscillator, 1-6J7 speech amplifier, 1-6L6 class A modulator. Power output of transmitter is 10 watts 100% plate modulated. Separate antennas are used for peak efficiency of both units regardless of frequency settings. Changeover from 6 volt to A.C. operation is extremely simple. All that is necessary is to remove the built in generator and insert the A.C. power supply. Supplied complete with all coils including coil for 10 meter reception.

- 6J5G-6J7-6F6-6E6-6J7-6L6
- Built in 350 volt 150. mil filtered generator
- Built in dynamic speaker
- 10 watts power output
- 100% plate modulation
- Absolutely independent receiver and transmitter
- Negligible receiver radiation
- Automatic phone jack

Ultra 6 tube Duplex complete with built in dynamic speaker, and A.C. power supply, wired & tested, with cabinet, less tubes, mike and antenna **\$28.90**
Ultra Duplex complete with built in dynamic speaker, and 150 mil generator, wired & tested, with cabinet, less tubes, mike and antenna **\$38.45**
Set of 6 Sylvania tubes **\$5.35**
American SB hand mike **2.95**
Adjustable 8 ft. antenna **1.60**

SENSATIONAL ULTRA 2-TUBE TRANS-RECEIVERS 2 1/2 to 4000 Meters

A.C.-D.C. MODEL
Numerous letters of appreciation received from the many purchasers of Trans-Receiver since its release a few months ago pronounces it as the sensation of the year. Never before was a unit of this type available at any price. This compact and self-contained unit will receive from 2 1/2 to 4000 meters with a high degree of excellence. Will receive foreign stations, amateurs, police calls, broadcast, press, airplane and weather reports, time signals, and all ultra high frequency stations. As a 2 1/2 to 5 meter transmitter surprising results will be obtained when calling friends from afar.

BATTERY MODEL
In compliance with countless requests we have designed a battery model of the now famous A.C.-D.C. Trans-Receiver. This remarkable unit uses 2 twin tubes, 19 & 1E7G which insure consistent loudspeaker volume and powerful transmission. Receives from 2 1/2 to 4000 meters, transmits on 2 1/2 and 5 meters. Cabinet is provided with handle (not shown) for portable use. May also be mounted in a car. The same features which characterize the electric model are incorporated in this unit.

FEATURES

- ★ Transmits from 2 1/2 to 5 meters
- ★ Receives from 2 1/2 to 4000 meters (12 bands)
- ★ Separate electrical and mechanical bandspread
- ★ Loud speaker volume
- ★ Automatic super-regeneration from 2 1/2 to 15 meters
- ★ House to house communication
- ★ Plate modulation

Either kit, unwired, less tubes and accessories
Set of 2 Sylvania tubes for electric model **\$7.15**
6J5G and 12A7 **\$1.65**
Set of 2 Sylvania tubes for battery model 19 and 1E7G **\$1.95**
Set of 4 coils 2 1/2 to 15 meters **.30c**
Set of 4 coils 15 to 200 meters **.95c**
Set of 5 coils 200 to 4000 meters **\$1.75**
American S.B. Handmike **\$2.95**
Cabinet less battery compartment **.95c**
Cabinet with battery and speaker compartment **\$2.25**
5-inch magnetic speaker **\$1.25**
Wired and tested **\$2.00**

3-Tube Portable Transceiver (2 1/2 VO 5 METERS) (Built-in Loud Speaker)



A compact powerful 2 1/2 & 5 meter portable transceiver designed for loud speaker operation, is now available in the Ultra 3 B. This remarkable unit will be found capable of maintaining positive contact when communication is once established. Class A 100% modulation is employed. This has been made possible by the new 2 Volt tubes; 1F4 Class A modulator-1B4 high gain speech amplifier. These together with a 19 tube, Oscillator-Super regenerative detector result in an ideal transceiver. When used as a receiver loud speaker volume is assured. Plate modulation. Supplied complete with all coils, including coil for 10 meter reception.

Complete kit of parts (including all coils), less batteries, tubes, speaker, microphone and cabinet unwired **\$9.95**
Wired and tested **\$2.50**
Sylvania 19, 1F4, 1B4 set of 3 matched tubes **\$2.50**
Cabinet with built-in speaker and battery compartment **2.25**
Cabinet less built-in speaker with battery compartment **1.95**
Cabinet less built-in speaker, less battery compartment **1.10**
American S.B. Handmike **2.95**
Matched speaker **1.25**

Ultra 1 and 2 Tube Battery Transceivers



(2 TUBE MODEL)

Complete kit of parts (including all coils), less tubes, cabinet, microphone and batteries. Wired and tested **\$2.00**
Sylvania 19 and 1F4 matched tubes (2) **1.45**
Cabinet less battery compartment **1.10**
Cabinet with battery compartment **1.95**
Hand microphone **2.95**

For the beginner in the field of ultra high frequencies we unhesitatingly recommend these extremely efficient 1 and 2 tube transceivers. Can be used as a 2 1/2, 5 and 10 meter receiver as well as transmitter when calling friends from afar. The one (1) tube unit uses a 19 type tube. The 2 tube unit uses one 19, plus the (new) 1F4. Class A modulator. Longer battery life is had with this combination. Greatest possible range of any small transceivers can now be had. Batteries required are 2-1 1/2 V. dry cells and 90 to 135 B battery.

PICTORIAL DIAGRAM FURNISHED WITH KIT (1 TUBE MODEL)

Complete kit of parts (including all coils), less tubes, cabinet, microphone and batteries, unwired **\$5.45**
Wired and tested **\$1.50**
1 Sylvania 19 tube **.69**
Cabinet less battery compartment **1.10**
Cabinet with battery compartment **1.95**
Hand microphone **2.95**

ULTRA 5T ALL WAVE

(1 1/2 to 600 METERS) 5-Tube A.C. & D.C. RECEIVER

Now with 25L6

- ★ New tubes 2-6K7, 1-6J5G, 1-25Z6, 25L6
- ★ Electrical bandspread
- ★ Receives phone & C.W. signals
- ★ Built-in dynamic speaker
- ★ Built-in power supply
- ★ Linear regeneration control
- ★ Dial illumination
- ★ Headphone jack

An all wave amateur communications receiver truly designed for the use of the discriminating amateur. A multitude of features are incorporated, a few of which are electrical bandspread, super regeneration from 1 1/2 to 15 meters, linear control of regeneration, and the new beam power 25L6 tube which delivers crisp, clean, high power output. 5 band switch coils cover the range of 15 to 600 meters. An ideal tube lineup is used as follows: 1-6K7 RF. stage, 1-6K7 regenerative detector, 1-6J5G super-regenerative detector, 1-25L6 beam power output tube, 1-25Z6 rectifier. The logical receiver for your station.

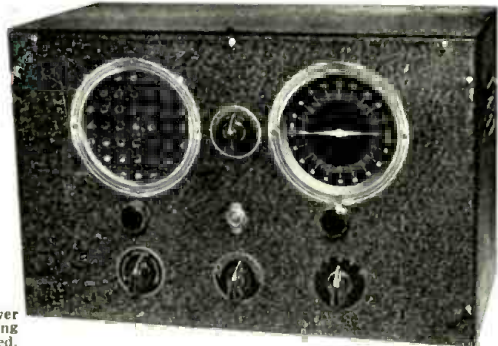

Complete kit of parts less tubes and cabinet unwired **\$3.00**
Wired and tested, extra **4.50**
Sylvania kit of 5 tubes **2.50**
Set complete with 5 tubes and cabinet, wired, ready to operate **\$13.95**
2.10

Ultra High Frequency Products Co., 123 Liberty St., New York, N.Y.

A FREE LESSON SHOWED BILL HOW HE COULD MAKE GOOD PAY IN RADIO



I CAN'T FIND OUT WHAT'S WRONG--- GUESS I'LL MAKE A FOOL OF MYSELF WITH MARY

HELLO, BILL--- GOT A TOUGH ONE TO FIX? LET ME HELP YOU

HELLO JOE--- WHERE'VE YOU BEEN LATELY--- AND WHERE DID YOU LEARN ANYTHING ABOUT RADIO?

I'VE BEEN STUDYING RADIO AT HOME, BILL, WITH THE NATIONAL RADIO INSTITUTE. YOU OUGHT TO TAKE THEIR COURSE. I'VE GOT A GOOD RADIO JOB NOW. LET'S MAKE A CIRCUIT DISTURBANCE TEST--- STARTING WITH THE AUDIO OUTPUT STAGE AND TESTING EVERY STAGE RIGHT BACK TO THE ANTENNA. LISTEN FOR THE CLICKS WHEN I TAP THE GRID LEADS

SAY--- WHERE DID YOU LEARN THAT TEST? IT'S A GOOD ONE

HERE'S THE TROUBLE, BILL, IN THE FIRST I.F. AMPLIFICATION STAGE. I LEARNED THAT TEST EVEN BEFORE I STARTED TAKING THE COURSE, BILL. IT'S DESCRIBED IN A FREE LESSON WHICH THE NATIONAL RADIO INSTITUTE SENDS YOU WHEN YOU MAIL A COUPON FROM ONE OF THEIR ADS

I'VE SEEN THEIR ADS BUT I NEVER THOUGHT I COULD LEARN RADIO AT HOME--- I'LL MAIL THEIR COUPON RIGHT AWAY

I'M CONVINCED NOW THAT THIS COURSE IS PRACTICAL AND COMPLETE. I'LL ENROLL NOW

AND THEN I CAN MAKE REAL MONEY SERVICING RADIO SETS

OR INSTALL AND SERVICE LOUD SPEAKER SYSTEMS

OR GET A JOB WITH A RADIO BROADCASTING OR TRANSMITTING STATION

AVIATION RADIO, POLICE RADIO, TELEVISION, ELECTRONIC CONTROLS--- RADIO IS SURELY GOING PLACES. AND THE NATIONAL RADIO INSTITUTE HAS TRAINED HUNDREDS OF MEN FOR JOBS IN RADIO

YES, I WILL SEND YOU MY LESSON ON RADIO SERVICING TIPS FREE TO SHOW YOU HOW PRACTICAL IT IS TO TRAIN AT HOME FOR A GOOD RADIO JOB



YOU CERTAINLY KNOW RADIO SOUNDS AS GOOD AS THE DAY I BOUGHT IT.

THANKS! IT CERTAINLY IS EASY TO LEARN RADIO THE N.R.I. WAY. I STARTED ONLY A FEW MONTHS AGO, AND I'M ALREADY MAKING GOOD MONEY.

THIS SPARE TIME WORK IS GREAT FUN AND PRETTY SOON I'LL BE READY FOR A FULL TIME JOB

OH BILL--- I'M SO GLAD I ASKED YOU TO FIX OUR RADIO. IT GOT YOU STARTED THINKING ABOUT RADIO AS A CAREER, AND NOW YOU'RE GOING AHEAD SO FAST

OUR WORRIES ARE OVER. I'M MAKING GOOD MONEY NOW, AND THERE'S A BIG FUTURE AHEAD FOR US IN RADIO

J. E. SMITH, President National Radio Institute Established 1914

ment and show you how to conduct experiments and build circuits which illustrate important radio principles. My training gives you practical radio experience while learning.

Get My Lesson and 64-Page Book FREE---Mail Coupon

In addition to my Sample Lesson, I will send you my 64-page Book, "Rich Rewards in Radio." Both are free to any fellow over 16 years old. My book describes Radio's spare time and full time opportunities and those coming in Television; tells about my Money Back Agreement; shows you actual letters from men I have trained, telling what they are doing and earning. Find out what Radio offers YOU! MAIL THE COUPON in an envelope, or paste it on a penny postcard---NOW!

J. E. SMITH, President National Radio Institute Dept. 71B3 Washington, D. C.

MAIL THIS NOW

J. E. SMITH, President, Dept. 71B3 National Radio Institute, Washington, D. C.

Dear Mr. Smith: Without obligation, send me a sample lesson and your free book about the spare time and full time Radio opportunities, and how I can train for them at home in spare time. (Please write plainly.)

Name..... Age.....
 Address.....
 City..... State..... 14x1

I HAVE TRAINED MANY MEN TO START A SPARE TIME OR FULL TIME RADIO SERVICE BUSINESS WITHOUT CAPITAL

Do you want to make more money? I'm so sure that I can train you at home in your spare time for a good Radio Job that I'll send you a sample lesson absolutely FREE. Examine it, read it, see for yourself how easy it is to understand even if you've never had any technical experience or training.

Many Radio Experts Make \$30, \$50, \$75 a Week

Radio broadcasting stations employ engineers, operators, station managers and pay up to \$5,000 a year. Spare time Radio set servicing pays as much as \$200 to \$500 a year. Full time Radio servicing jobs pay as much as \$30, \$50, \$75 a week. Many Radio Experts own and operate their own full time or part time Radio sales and service businesses. Radio manufacturers, servicemen, paying up to \$6,000 a year. Radio operators on ships get good pay and see the world besides. Automobile, police, aviation, commercial, Radio, and loud speaker systems offer good opportunities now and for the future. Television promises many good jobs soon. Men I have trained are holding good jobs in all these branches of Radio.

Many Make \$5, \$10, \$15 a Week Extra in Spare Time While Learning

Practically every neighborhood needs a good spare time serviceman. The day you enroll I start sending you Extra Money Job Sheets. They show you how to do Radio Repair jobs that you can cash in on quickly. Throughout your training I send you plans and ideas that have made good spare time money---from \$200 to \$500 a year---for hundreds of fellows. I send you special Radio equip-

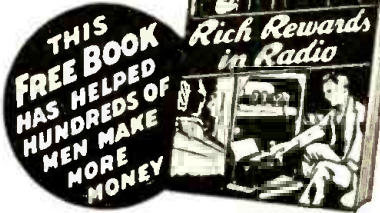

Please mention SHORT WAVE & TELEVISION when writing advertisers

IN THIS ISSUE: PROMINENT SHORT-WAVE AND TELEVISION AUTHORS

Von Ardenne • Lynch • Burrows • Morandini • Shuart • Hooton

HUGO GERNSBACK
Editor



H. WINFIELD SECOR
Managing Editor

GEORGE W. SHUART,
W2AMN
Associate Editor

Combined With
Official SHORT WAVE LISTENER

Contents for August, 1937

Editorial—"Ultra-Short-Wave Possibilities," by Baron Manfred von Ardenne.....	163
Lorenz Short-Wave Beam Lands Planes BLIND!.....	164
Television Pictorial.....	165
Lighting Lamp by S-W Radio (Cover Feature).....	166
The "Surface Wave" in Radio Transmission, by Charles R. Burrows.....	167
Getting the Best Results from Your Short-Wave Receiver.....	167
New CBS TELEVISION Station for New York City.....	168
A Real De Luxe "Ham" Station, D. Reginald Tibbetts, W6ITH-W6XT.....	168
The "Steerable" Antenna—How It Works.....	169
A New Television System Using "Dual" Cathode Ray Tubes, by D. M. Morandini.....	169
What Modulator Power Should We Use?, by George W. Shuart, W2AMN.....	170
A Novel "Regen." 2-Tuber, by Harry D. Hooton, W8KPX.....	171
The "S. W. & T." Communications Receiver, by George W. Shuart, W2AMN.....	172
The 5-40-400 Transmitter, by Arthur H. Lynch, W2DKJ.....	174
Short Wave Scouts—40th Trophy Winner.....	176
\$5.00 for Best Short-Wave KINK.....	177
Let's "Listen In" with Joe Miller.....	178
World S-W Station List, by M. Harvey Gernsback.....	179
Short Waves and Long Raves.....	180
World-Wide Short-Wave Review, Edited by C. W. Palmer.....	182
What's New In Short-Wave Apparatus.....	184
Short-Wave QUESTION BOX.....	188
Short-Wave League—When to Listen In, by M. Harvey Gernsback.....	198
How to Identify S-W Stations.....	207

Certified Circuits



● **SHORT WAVE & TELEVISION** goes to a large expense in verifying new circuits. When you see this seal it is your guarantee that such sets have been tested in our laboratories, as well as privately, in different parts of the country. Only "Constructional-Experimental" circuits are certified by us.

When you see our certified seal on any set described, you need not hesitate to spend money for parts, because you are assured in advance that the set and circuit are bona fide and that this magazine stands behind them.

SHORT WAVE & TELEVISION is the only magazine that certifies circuits and sets.

OUR COVER

● Since the advent of practical radio code transmission at the dawn of the century, inventors have striven to perfect a means whereby power could be successfully transmitted by radio waves. The limitations on this method of transmitting power are set forth in the cover illustration article this month—Lighting a Lamp by S-W Radio—see page 166.

COPYRIGHT, 1937, BY H. GERNSBACK

Published by **POPULAR BOOK CORPORATION**

404 N. Wesley Avenue, Mount Morris, Ill.

Editorial and Executive Offices - - - - 99-101 Hudson St., New York, N. Y.
HUGO GERNSBACK, President - - - - **H. W. SECOR**, Vice-President
EMIL GROSSMAN - - - - - Director of Advertising
 European Agent: Gorrings's American News Agency, 9A Green St., Leicester Square, London W. C. 2
 Australian Agents: **McGILL'S AGENCY**, 179 Elizabeth St., Melbourne

Features in September Issue

- Double feature transmitter—Has Hi-power "Pen-Tet" Exciter Unit and 400-watt Final Amplifier; exciter unit can be used alone as 50 to 100 watt transmitter. By George W. Shuart, W2AMN.
- 1-Tube Receiver—Especially designed for the Beginner. Has new features.
- Short-Wave Transmission and the Ionosphere, by Dr. A. G. McNish, Department Terrestrial Magnetism, Carnegie Institution of Washington, D. C.
- World's *Smallest* Receiver, by H. G. McEntee.
- Weather Forecasting by Short Waves, by J. Merino y Coronado.
- An Improved S-W Pre-selector, by R. P. Adams.

SHORT WAVE & TELEVISION—Monthly, Entered as second-class matter May 7, 1930, at the post office at Mount Morris, Illinois, under the act of March 3, 1879. Trademarks and copyrights by permission of H. Gernsback, 99-101 Hudson St., N. Y. C. Text and illustrations of this magazine are copyrighted and must not be reproduced without permission. **SHORT WAVE & TELEVISION** is published on the 1st of every month. Twelve numbers per year. Subscription price is \$2.50 a year in the United States and possessions and Canada. Foreign countries, \$3.00 a year. Single copies 25c. Address all contributions for publication to Editor **SHORT WAVE & TELEVISION**, 99-101 Hudson St., New York, N. Y. Publishers are not responsible for lost manuscripts. Contributions cannot be returned unless authors remit full postage. **SHORT WAVE & TELEVISION** is for sale at all principal newsstands in the United States and Canada. European agents: Brentano's, London and Paris. Printed in U. S. A. Make all subscription checks payable to Popular Book Corporation.

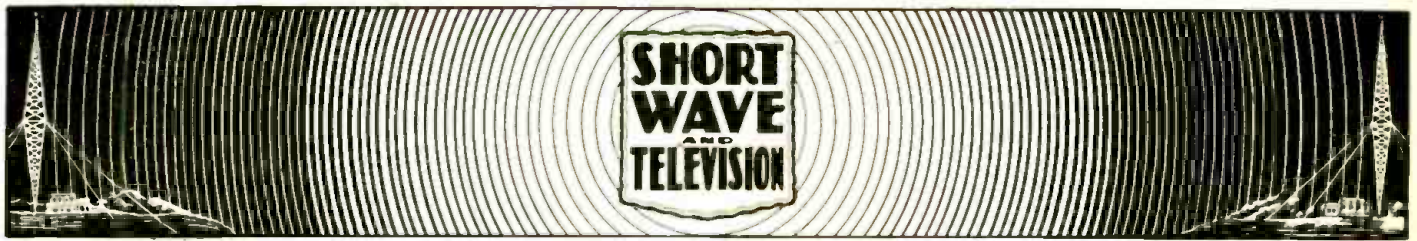

Ultra-Short-Wave Possibilities

By Baron Manfred von Ardenne,
Berlin, Germany

● **ULTRA-SHORT-WAVES** in the region of four to eight meters provide practically interference-proof radio transmission and reception, which advantage has been particularly noticeable in tests made during the summer months, up to date, in the larger cities. On the longer wavelengths static and other interference are quite pronounced. Of course, the interference-free pick-up from one of these ultra-short-wave stations (such as those being experimentally tested for television in New York, Philadelphia, and numerous European cities) is enjoyed only in the rather limited area which falls, practically, within the *visible range* extending around the antenna. The higher the antenna, of course, the greater the visibility or line-of-sight range.

Not only are these very short waves, in the general region of four to eight meters, highly suitable for the transmission of extremely broad frequency bands, but they also permit real *high-fidelity* reception at the locations where this is not otherwise possible, at present, because of the high interference level.

In addition to the advantage of undisturbed reception, ultra-short-waves offer the possibility of extending the audio-frequency range which can be transmitted; so that frequencies as great as 15,000 to 20,000 cycles may be reached. Furthermore, the non-linear distortion can be kept to an extremely small value because the required percentage of modulation need not be as high as in radio transmission over the customary broadcast range.

This slight percentage of modulation is here possible because, with ultra-short-waves, one does not have to consider those listeners residing at a considerable distance from the transmitter. But for those living in the restricted area of the *visible range* of the ultra-short-wave transmitter, a small percentage of modulation is sufficient to give a signal of sufficient energy to provide satisfactory reception of programs in their homes. Finally, we have another thought in this direction: ultra-short-wave transmission, when radiated with low percentage of modulation, permits a considerable extension of the amplification in respect to very minute levels of sound intensity.

Because of the fact that a much wider audio-frequency band can be transmitted with the ultra-short-waves, and also because of the decrease of non-linear distortion at the

transmitting, as well as the receiving apparatus (plus the extension of dynamic range of loudness or strength of signal) we see that broadcasting on ultra-short-waves promises a brilliant future. Ultra-short-wave broadcasts will permit a quality of reproduction at the receiver superior by far to the quality of the present broadcast transmissions. However, this is only part of the improvement that the application of ultra-short-waves promises for us in the realm of sound transmission tomorrow.

transmission tomorrow.

About seven years ago, the author published an article in which he proposed to modulate, on a *single* short-wave beam, a number of different radio programs. By means of a specially-designed converter set, containing a suitable detector unit designed for use in connection with the customary broadcast receiver, the various programs are to be separated. The different frequencies, thus separated, will filter out in the manner described and are then reproduced by the ordinary broadcast receiver in the usual way.

Compared to the customary method of modulating a number of ultra-short-wave beams, each channel with a separate program, this novel method (first proposed seven years ago) would have provided the possibility of utilizing the present type of broadcast receiver without any constructional changes for this purpose. In addition to this, the proposed method made it possible to tune the broadcast receiver in the usual manner.

At that time the author proposed (see his article in *Vielfachrundfunk auf einer Kurzwelle*, ETZ 1930, issue No. 47) to install relay receiving stations outside of large cities. Because of the excellent DX (distant) reception possibilities at locations with low interference-level, the DX programs picked up would be much better than those heard by listeners living in the interference zones surrounding the structures of large buildings. These DX programs, it was proposed, were to be sent to the ultra-short-wave transmitter by means of (co-axial) cable and, in turn, *rebroadcast* to the listeners.

This idea has, as yet, not been tested, at least not under practical conditions, because it had one fault—it was made seven years too early! At that time the transmission and reception of ultra-short-waves was something entirely new, and only a few engineers pos-

(Continued on page 194)



Baron Manfred von Ardenne, well known in Europe for his researches in television and ultra-short waves, maintains an extensive laboratory. The Baron was one of the first to successfully reproduce and also pick up television images on a cathode-ray tube, and he also conducted some of the first tests with dual transmission of voice and image on the same wavelength.

Eighth of a Series of "Guest" Editorials

SHORT WAVE & TELEVISION IS PUBLISHED ON THE 1st OF EVERY MONTH

This is the August, 1937 Issue—Vol. VIII, No. 4. The Next Issue Comes Out August 1

SHORT WAVE & TELEVISION, Published monthly at Mount Morris, Ill.

EDITORIAL and EXECUTIVE Offices, 99 Hudson St., New York City

LORENZ Short-Wave Beam Lands Planes BLIND!

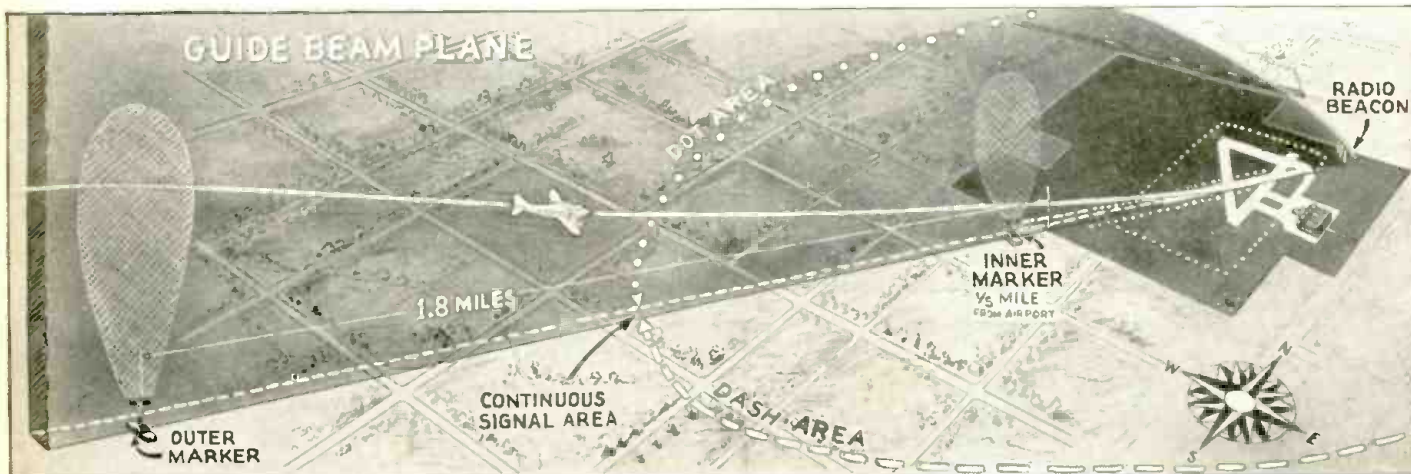

The illustration above shows how the Lorenz short-wave "landing beam" system for airports was installed and demonstrated at the municipal airport at Indianapolis.

● RECENTLY a very interesting demonstration was given at Indianapolis, for representatives of American airlines, as well as those representing the Navy and other departments of the government, of the Lorenz short-wave landing beam for aircraft.

By utilizing this clever short-wave system worked out by a German engineer, it is possible for the pilot of a plane to bring his ship down to an airport, even in the heaviest fog, as was demonstrated recently. One of the accompanying pictures shows how the main marker beacon slants down toward the airport or the landing field. The pilot, to begin with, flies along one of the regular radio beacons now extended along the principal air routes of the country, until he approaches the field equipped with the new Lorenz landing beacon system, which happened to be at Indianapolis.

When the pilot approaches to within a distance of about 1.8 miles of the

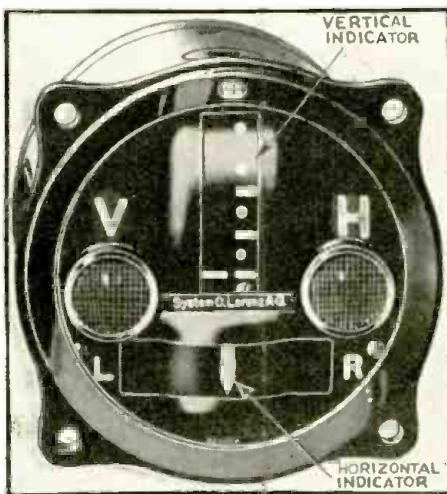

The visual indicator installed in the pilot's cockpit aboard the plane: the "inner" and "outer" beacon lights appear at the left and right; the horizontal and vertical "beam flight" indicators are so marked in the photo.

As the pilot begins to fly down the beam, guided by the indicating needles on the instrument just described, after a period of about 1½ to 2 minutes he receives a second marker beacon signal which is radiated vertically by the "inner marker" beacon transmitter shown in the picture. The "inner marker" short-wave signal is given at a distance of about 1/5th mile, or .3 km. from the boundary of the landing field, a few seconds before the plane reaches this boundary. This signal is brought to the attention of the pilot in two ways—by the lighting of the right-hand lamp, "H," on the visual indicator in front of him, and also by the reception of a rhythmic short-keyed high-pitched note in his headphones. On the average, the plane will be at a height of 60 ft. when reaching this "inner beacon" and having received the "inner beacon" signal he is neither to right, nor left, nor above, nor below the radio beacon beam—thanks to the horizontal and vertical indicating needles on the instrument before him in the cockpit of the plane. The pilot can (Continued on page 192)

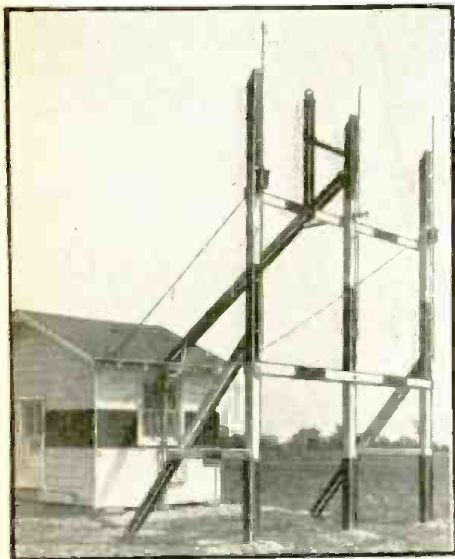

The complete short-wave radiator system and transmitter house installed at the Indianapolis airport for test of the Lorenz system, the demonstration of which was very successful.

boundary of the landing field, he receives two signals from an "outer marker" beacon as the diagram shows; the visual signal notifying him that he has reached this "outer marker" takes the form of a flash on the lamp indicator on the left side of the indicating instruments on the plane. At the same time, the pilot hears a deep note of about 700 cycles per second in the headphone.

At the bottom of the instrument there is an indicating needle which may swing from left to right, and it's the pilots job to keep the plane flying along the landing beacon signal by steering the plane so that this needle is always in the center, between "L" and "R." In order to fly down the beam there is also an indicating needle which moves up and down in the top center portion of the instrument on the panel before the pilot. If this needle rises above the center division, it indicates that the pilot should raise the tail of his plane, and if the needle moves below the center mark, it indicates that he should lower the tail, or, that he is flying too low on the radio beam.

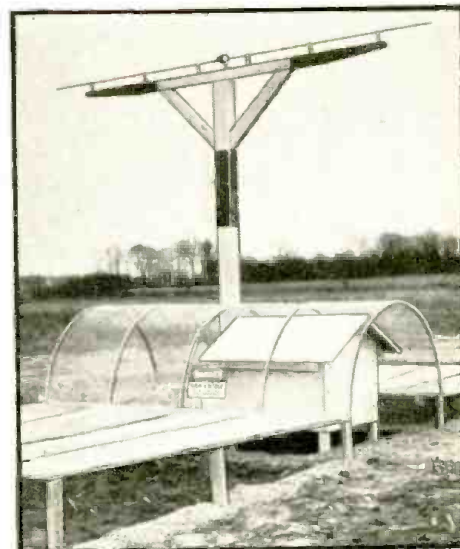

Above—The complete "signal" transmitter installed at the Indianapolis airport.

TELEVISION PICTORIAL

Recent advances in television, both in this country and abroad, are shown in the accompanying illustrations, including activities of the NBC, Baird—in England, and recent German developments.

Below—large screen television apparatus as demonstrated in England by John Logie Baird. Note that the television projector is mounted in a small "house" backstage. The studios where the images are picked up is located in another part of the theatre; no attempt was made to pick up the high-fidelity images broadcast by the BBC. A mirror drum scanning system is used.



↑ Betty Goodwin, charming television announcer at the NBC studios. This is an actual photograph of the television image as reproduced with 441 lines on the cathode ray tube receiver of RCA design. Even though a slight scanning line effect will be noted in the photo, it is interesting to note, in passing, that when one actually views the new 441 line images, no noticeable scanning lines can be seen, the images resembling those obtained with home movies. Miss Goodwin not only televisions very well. She has had the honor of introducing many celebrities via television.

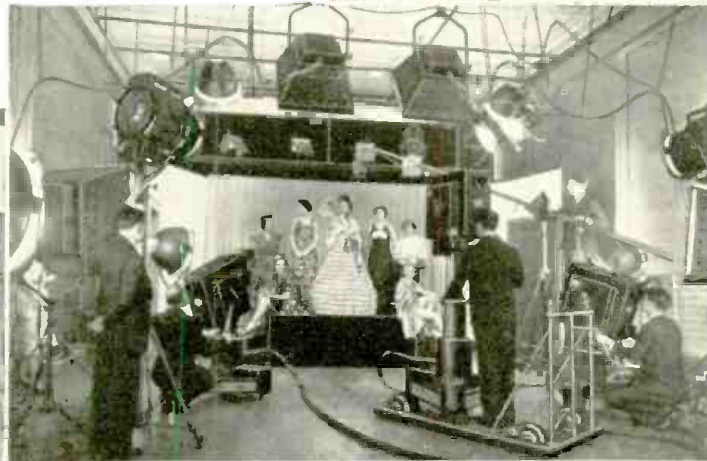
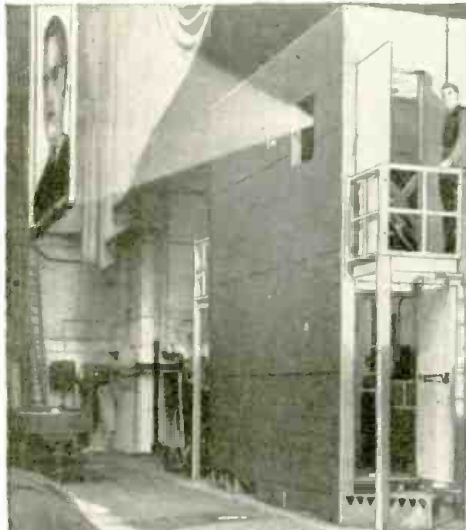

Above—Inside the NBC television studio in New York City. This summer fashion show was televised and broadcast from the high-fidelity transmitter atop the Empire State Building for the benefit of the official "Televiewers," mostly engineers of the company who have "test" sets in their homes in New York and vicinity.

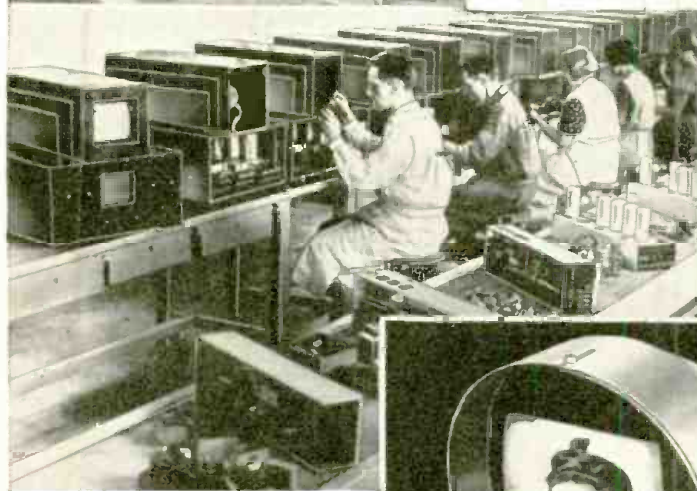

Above—German television receivers on the factory "assembly line." American television "fans" are hopeful that before many months have passed this will be a familiar sight in American radio factories, and that television will rapidly become one of our daily conveniences in the home. Photo at right shows a close-up of one of the German television receivers; note the loudspeaker at the bottom of the set, through which the sound is reproduced. The engineers have greatly simplified the television receiver, especially in the reduction of the number of tubes necessary for both image and sound reception. The image is built-up on the enlarged end of the cathode ray tube, which is placed within a funnel-shaped metal shield, as the picture discloses.



Yesterday!



Today!

Above—at left, "Felix the Cat" as he appeared to television "lookers-in" a few years ago, with 60-line scanning—pretty poor, what? At right, above, "Felix the Cat" as seen today, with the new improved 441-line NBC scanning.

Below—Latest German television receiver. Right—Handsome English television receiver, with image reflected on mirror.

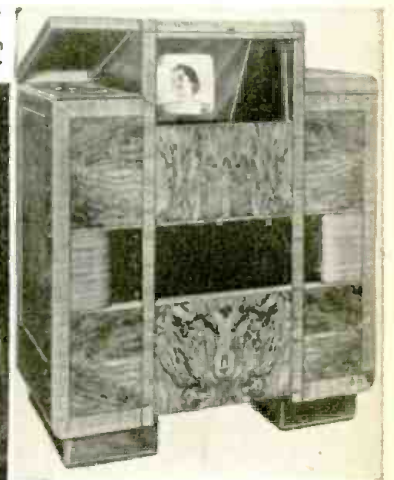
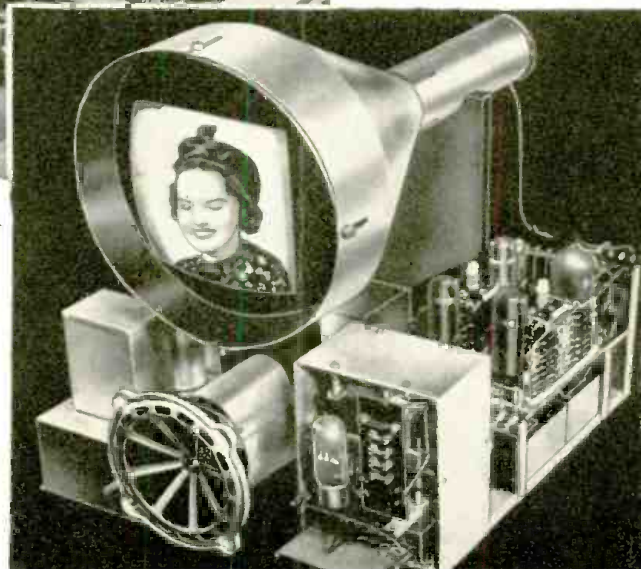

↑ Above—English television receiver—a very handsome creation. The set used is the Marconi-EMI television chassis, in which the image is reproduced by a vertically mounted cathode ray tube; the image is reflected from the end of the tube by a mirror placed at an angle as shown. All of the tuning knobs are mounted on a small control panel under the folding lid at the left side of the cabinet.

LIGHTING LAMP

by S-W Radio

(Cover Feature)

At a recent scientific demonstration a lamp was lighted by radio energy transmitted a distance of ten feet. The whys and wherefores of radio power transmission are discussed briefly in the accompanying article and will prove of interest to students as well as laymen, as this subject is one that keeps cropping up recurrently.

● RECENTLY at a scientific lecture given in Philadelphia, an incidental feature of the lecture was the demonstration of lighting a lamp by radio waves transmitted over a distance of about 10 ft. Diagram A on this page

ter, one to supply 7.5 volts for the filament of the 800 type tube, and a second transformer to deliver anywhere from 600 to 1,000 volts, 60 cycle A.C., for exciting the plate circuit of the 800 tube. The antenna rods are each equivalent to

it is that if we can demonstrate the lighting of a lamp over a distance of 10 feet, for example, that we should not go ahead and endeavor to transmit power on a commercial scale over distances of miles instead of yards.

The principal reason why the radio transmission of power is not feasible is because of the very inefficient operation of such a system. The radio wave energy transmitted by wave motion between the two antennas in the demonstration here illustrated (as well as in our front cover picture) falls off rapidly as the distance between the receiver and the transmitter increases. In fact, the intensity of the radiation field falls off inversely proportional to the distance.

For the radio student it is interesting to remember that when energy is transferred from one coil to another, where the coils are inductively related—or only separated a short distance—that the field picked up in the second coil is inversely proportional to the cube of the distance from the coil. Signals can, and have been, transmitted by this inductive field, making use of alternating currents with frequencies from 300 to say 3,000 cycles, etc., and this is known as *induction signaling*.

When we come to the radio antenna, the *induction field* radiated by this antenna results in the field intensity picked up at a *receiving antenna* being inversely proportional to the square of the distance from the antenna. This induction field (Continued on page 191)

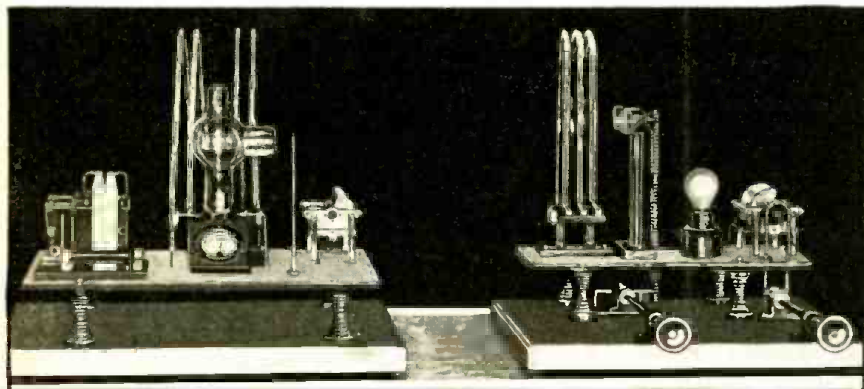

Apparatus installed at the Franklin Institute, Philadelphia, Pa., whereby visitors can obtain a visual demonstration of the "radio transmission of energy." By turning one of the control knobs on the receiver at the right, the lamp can be lighted and extinguished by rotating the condenser plates. The circuit may also be tuned by varying the inductance by rotating the left-hand knob on the receiver.

shows the set-up used in this particular demonstration. The radio transmitter operated on a wavelength of 3 meters or 100 mc., and had a power input of 200 watts. The antenna rods should be a little less than 1/4 wavelength, which is 3/4 meter (29.5 inches).

a little less than one-quarter wavelength. Every so often this proposition of transmitting power by radio waves comes up or breaks into the public press. The layman frequently asks why

At the receiver the two antenna rods are connected to a lamp and a little experimenting will have to be done at this point with different size lamps; one of 15 to 20 watts may be tried at first and of course the closer the receiving antenna system is placed to the transmitter, the greater the amount of energy picked up by the antenna and the brighter the lamp will glow. Likewise, the smaller the distance between the transmitting and receiving antennas, the larger the size of the lamp bulb that can be lighted and vice versa. Neon lamps can be experimented with also.

Diagram B shows an experimental set-up for lighting a lamp by short waves on about five meters wavelength or 60 mc. This circuit has the transmitter tunable as well as the receiver. For the receiving circuit the coil may be like the one used at the transmitter; likewise the tuning condenser may be of similar size or 20 mmf. The size of the lamp will have to be varied until best results are obtained over the distance which it is desired to demonstrate this phenomenon. Two small transformers are necessary at the transmit-

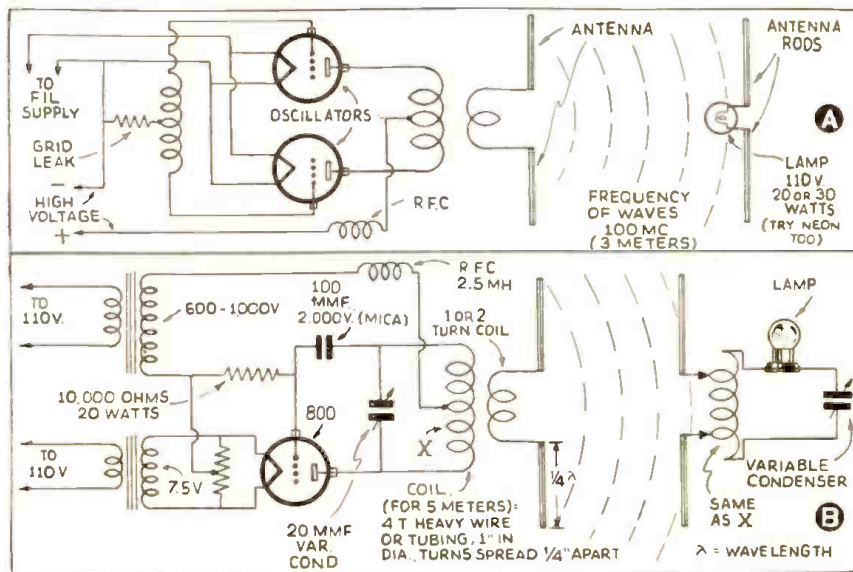
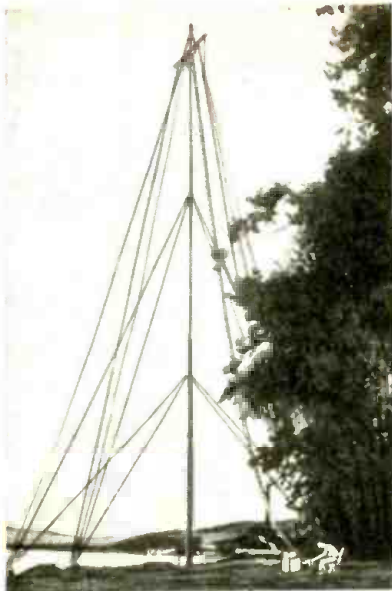

Diagram above shows plan for setting-up radio transmitting and receiving system for lighting lamp.

The "Surface Wave" in Radio Transmission

By Charles R. Burrows

Radio Research, Bell Telephone Laboratories



Photos by Bell Telephone Labs.

Fig. 3—One of the portable 25 meter masts from which the antennas were suspended.

● RADIO engineers have believed for a number of years that the radiation from a vertical antenna has a component which is guided by the earth as waves are guided by a pair of wires. Recent experiments and mathematical studies by the Laboratories indicate that this component, which has been called "the surface wave," is not present in ordinary radio transmission.

Some years ago, theoretical studies by Zenneck and Sommerfeld suggested that a surface wave existed in radio transmission, and in spite of the fact that an independent theoretical study by Weyl gave quite different results from Sommerfeld's, the surface-wave concept came to be widely accepted, because it gave a plausible explanation of the propagation of radio waves to great distances and around the curvature of the earth.

Only since the development of ultrashort wave radio, however, has it been possible for Laboratories' engineers to perform a crucial experiment which would settle the question as to which result was correct. The decision, which has since been confirmed theoretically by S. O. Rice, was found

to be in favor of Weyl's formula, which does not contain any term corresponding to the surface wave.

If there were a surface wave of this type it would be most pronounced when transmitted over a good dielectric, the nearest practical approach to which is fresh water. Accordingly, the first attempt was made over Budd Lake, New Jersey. The tests indicated that the water was so shallow that the transmission resembled that over land instead of over fresh water. An experiment over deep fresh water was therefore planned and has recently been successfully performed.

There are two properties of the surface wave by which its presence should be observable: (Continued on page 206)



Fig. 1—To determine the variation of the field strength with distance the receiver was located in a small motor-boat which towed a rowboat with the transmitter aboard.

Getting the Best Results from YOUR Short-Wave Receiver

How to overcome interference . . . Boosting weak signals . . . The choice of aerials . . . Hearing ten meters on average all-wave receiver.

● MANY of our readers who have invested in a fairly high-priced short- or all-wave receiver frequently run into a snag, such as interference caused by code signals, or possibly distant stations come in extremely weak. These, and

many other problems now and then beset the average short-wave listener, and a few suggestions are given herewith which may help to eliminate some of these frequently annoying problems.

The writer has heard many favorable reports on the special antenna tuning system shown in Fig. 1. This method of tuning out interfering stations was devised by G. W. Shuart, W2AMN. Reports on this antenna showed far great-

er sensitivity afforded by this circuit, the strength of distant weak signals being boosted considerably. Data for the winding of the tuning coil and the size of the condensers used are given in the diagram.

Aerials

Aerials are always more or less a problem. It is important to note that the direction of (Continued on page 205)

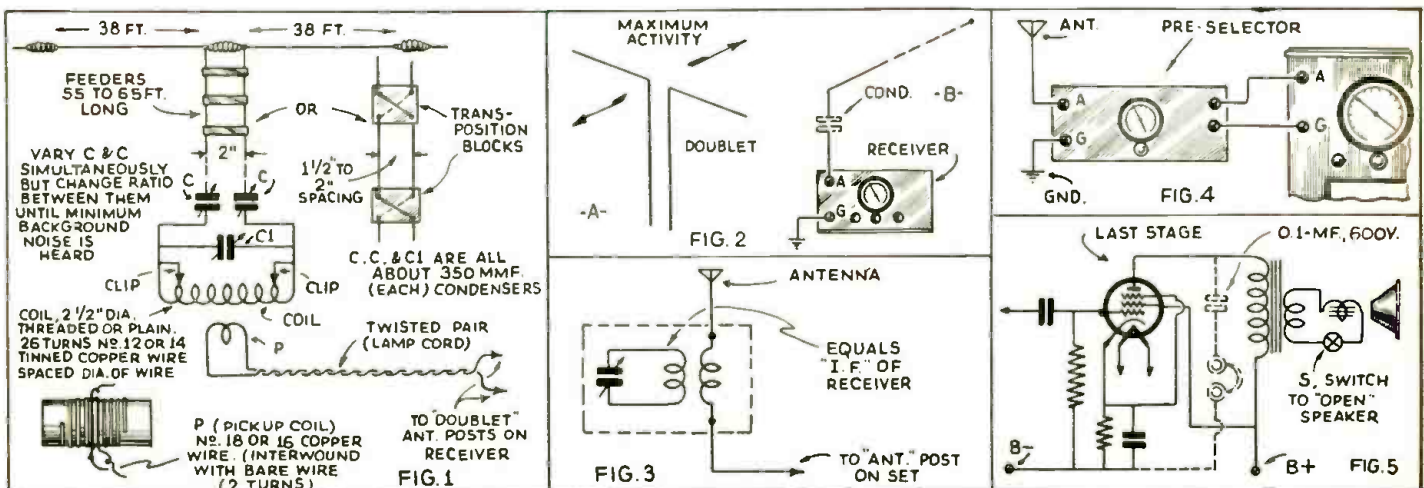

Several hints are illustrated above which will help the average short-wave enthusiast to greatly extend his receiving range, as well as the frequency spectrum over which signals may be heard.

New CBS TELEVISION Station for New York City

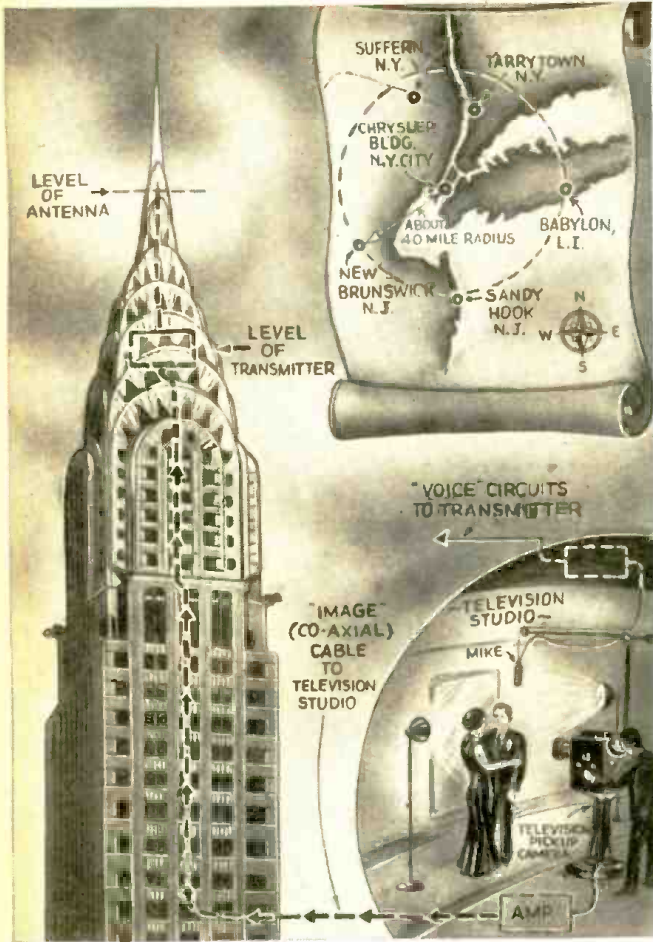

● IN New York City one of the outstanding skyscrapers is the famous Chrysler tower. This is located in the mid-town section, and the accompanying illustration shows the proposed location of the new CBS television transmitter and the antenna in the upper part of the building.

The location of the studio has not been settled upon just yet, but in any event, wherever it is finally located, possibly in a theatre somewhere near the Chrysler building, this studio will have its program carried through a coaxial cable to the 30 kilowatt transmitter atop the Chrysler building. It is proposed to build the antenna in a very inconspicuous manner around the part of the tower or structure just below the stainless steel needle. In this way, a distance of approximately 100 ft. only will separate the transmitter from the antenna, and thus make possible a practically distortionless transfer of power.

CBS have not been active in television lately, but many of the earlier television experimenters will remember the excellent programs which were produced on the old 60 line images. The new transmitter, which will not be in operation for several months, will use the new high fidelity 441 line scanning base. This high lineage will ensure very excellent images, comparable with those now being experimentally broadcast from NBC's transmitter located atop the Empire State Building, and (Continued on page 194)

← Left—the famous Chrysler Building in New York City where the new CBS television transmitting station and aerial will be located. The exact location of the studio has not been settled, but we are advised that it will not be in either the Chrysler or CBS buildings. The radius of the station will be about 40 miles, and the power 30 kw.

A Real De Luxe "Ham" Station D. Reginald Tibbetts, W6ITH-W6XT

Proud owner of one of America's largest amateur stations

● I KNEW I would have to build a special house for my new transmitter after having decided to expand from the old transmitter, composed of five standard relay racks. Many sites near and around Berkeley,

California were considered and after carefully considering over eighty, the one was selected that stood head and shoulders above all others. This is located on top of Kensington Mountain, just north of Berkeley.



D. Reginald Tibbetts. Mr. Tibbetts holds the title of "Communications Consultant." He was Engineer in Charge of Design and Operations for the radio-telephone system used in building the San Francisco-Oakland Bay Bridge. He has had a varied electrical and radio engineering experience and built the first police radio system west of Chicago, for the city of Berkeley in 1927. He is a graduate of the University of California with the degree of B. S. in electrical and communication engineering. His "Ham" station has been heard practically all over the United States and in many foreign Countries.

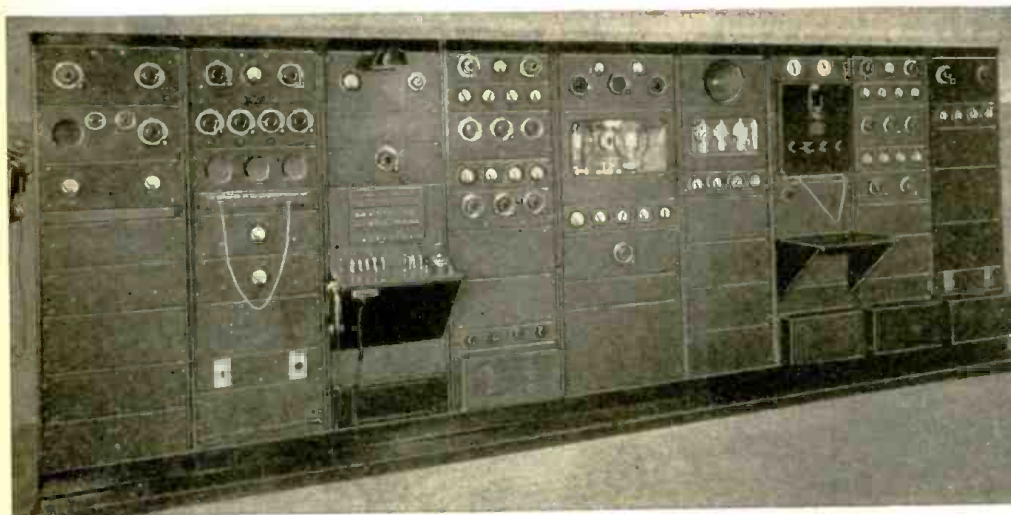

Yes, fellows, this is an "amateur" station! This beautiful layout is owned and operated by D. Reginald Tibbetts, W6ITH, W6XT, of Berkeley, Calif. Transmitters for all the usual wavelengths are incorporated in the general "line-up," as well as the latest type of receivers.

Five separate transmitters compose the equipment. Each transmitter is complete within itself and any or all can go "on the air" at the same time. All transmitters are of different types. (Continued on page 204)

The "Steerable" Antenna—How It Works

Noise Reduction a Salient Feature

● WHEN a radio station receives signals from only a single transmitter as in transoceanic radio telephony, it is profitable to use an antenna which is insensitive in all other directions and thus excludes as much noise as possible. The range of vertical angles from which useful signals may approach is considerable, and sharply-discriminative antennas cannot be used unless they can be pointed or "steered" directly into line with the incoming signal.

Messrs. H. T. Friis and C. B. Feldman of Bell Telephone Laboratories in their paper entitled, "A Multiple Unit

Aerial view of the multiple unit "steerable antenna" in operation at Holmdel, N.J. (Bell Telephone Lab's. test station).

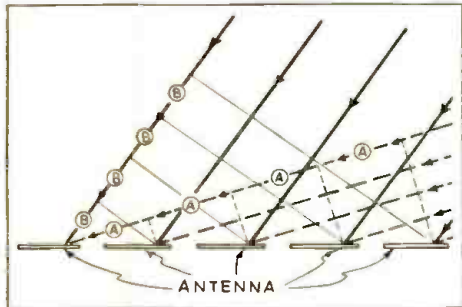
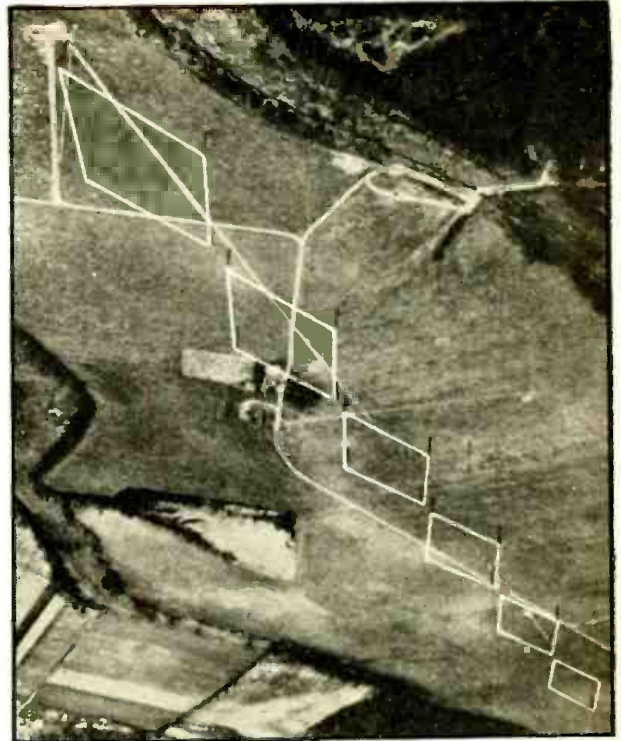

Diagram shows how waves coming in from different angles arrive at the antennas at different time intervals, A, A and B, B etc.

Steerable Antenna for Short Wave Reception," presented at the Silver Anniversary Convention of the *Institute of Radio Engineers*, described a system in which steering can be accomplished by combining the signals received over several antennas so that they all add up in phase. Antennas which, for commercial purposes, might be as many as fifteen or twenty, are stretched out for about two miles on a line toward the transmitting station. Transmission lines conduct the received signals from the antennas to the receiving apparatus, which includes phase-shifters for combining the signals so that they may be made to add up from any desired direction.

The present experimental system uses six antennas and three separate

combining-circuits are tapped off the lead-ins. An operator observes the signal on one of the combining-circuits and "sweeps" it up and down until he finds a good signal. If the system were to be used for transoceanic telephony, he would then set one of the other circuits to that angle, and would connect its output to the telephone line. Usually a second (Continued on page 201)

A New Television System Using "Dual" Cathode Ray Tubes

by Dyonis M. Morandini, M.A., M.E., E.E.,
Lecturer in Physics, Research Director of the California Television Society.

● THE last few years have seen rapid and increasingly accelerated advances in television art and technique. Recent inventions brought television well within the scope of actual and immediate practical exploitation. The improvements in cathode ray tubes, and other electronic devices, for instance, the design of what we may call, for our purposes, a "concentric television cable," (the work of the American Telephone and Telegraph Company's engineers) and so on, made television not only possible but also practical.

The author believes that his *two-way television tube* is a significant simplification in the machinery and operation of television devices, certain advantages of this tube having

*1932. Television News, 80-81, 100. Sept.-October, 1932.
**1932. Television News, 174-6, 201-202. May-June 1932.

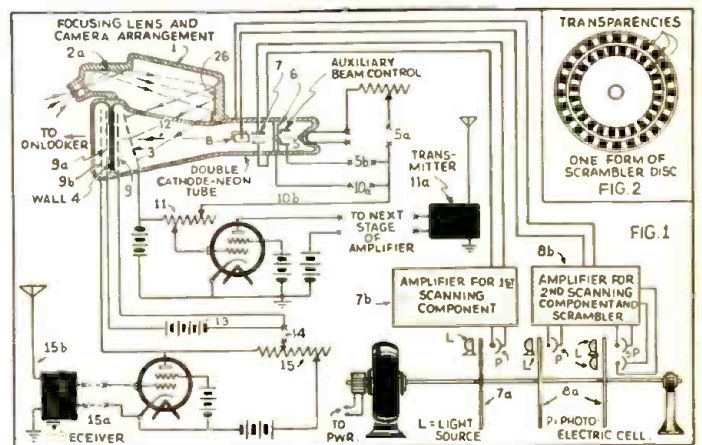

Above—Schematic diagram of the author's new television system employing "dual" cathode ray tube for transmitting and receiving images simultaneously. Diagram at left shows author's telephone-television scheme, utilizing two-way cathode tubes with centrally located "disc" frequency generator and scrambler.

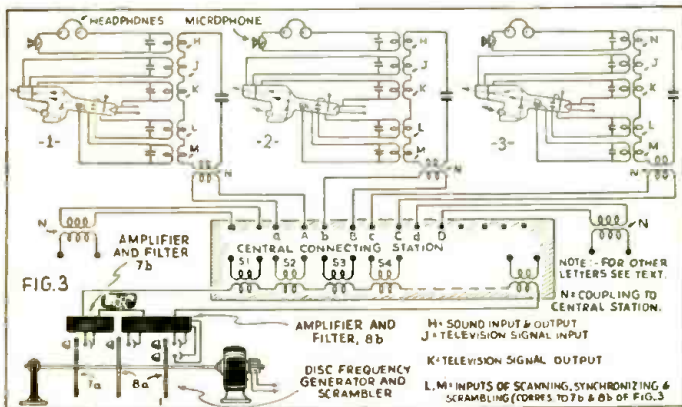

been already noted elsewhere, (in earlier "Television News" articles, etc.) At the present time the intention is to show how this device has the potentiality to soon step out of the confines of the research laboratory and fit itself into a common or *secret* telephone communication system, be it through the medium of wire or radio.

In order to understand the principle of the *secret* television system and the *two-way* cathode ray* tube one has only to consult Figs. 1 and 2. In Fig. 1—the connection of the two-way television tube and the disk frequency-generator** is demonstrated. The two scanning (Continued on page 205)

What MODULATOR POWER Should We Use?

By George W. Shuart, W2AMN

● IN the June, 1937 issue of this magazine the writer made the following statement: "Since only approximately 25% of audio power is needed for given input to the modulated R.F. amplifier, this modulator will modulate nearly 500 watts of input."

Some simple truths about *voice modulation* of an amateur transmitter with a class "B" modulator, together with a complete discussion of how and why the 25% versus 50% argument started are contained in this article. Every "Ham" interested in phone transmission should study this article.

The above statement aroused considerable criticism and discussion, and in this article we will endeavor to point

peaks; which, of course, anyone will admit can easily be accomplished.

Another method of accomplishing

acoustical research engineer of the Bell Telephone Laboratories.

In Fig. 2, we have shown a syllable, "oo" from the word "toot." Here we see that the *average amplitude* is extremely *low* compared with the *peak amplitude*, and also we see that the peak occurs for only a short length of time and quite infrequently. It can be generally stated that this peak will have a duration of less than .04 second and will occur at frequencies varying from 150 to 300 or 400 times per second, depending entirely upon the particular voice pronouncing the word. The ratio of *average peak* to *maximum peak* in this syllable expressed in units is 2.35 to 7. This was demonstrated by prominent telephone engineers after examining a number of voices.

Since the *intelligibility* of the spoken word is carried in frequencies above 600 cycles, those maximum peaks which are shown in the chart could be entirely eliminated and still not destroy communication. For instance, tests have proven that a filter system eliminating all frequencies below 500 cycles eliminated 60% of the *energy* in speech, but only reduced articulation 2%. This all has a definite bearing upon modulating problems, because even if our modulators were not capable of reproducing the maximum (Continued on page 196)

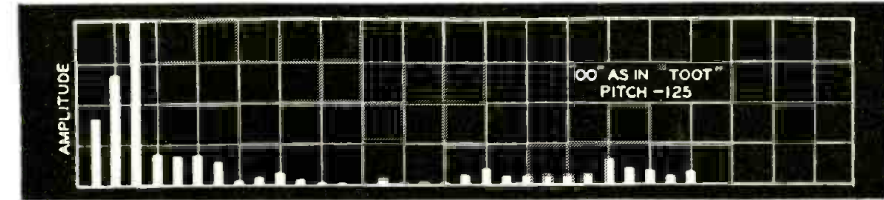

Courtesy of D. Van Nostrand Company, Inc.

This chart shows amplitude variations in "oo" from the word "toot." Fig. 2.

Both charts on this page are reprinted from "Speech and Hearing" by Harvey Fletcher.

out some of the seldom discussed points on modulation.

First, let it be thoroughly understood that in the statement quoted above, the author did not mention 100% modulation. The modulator referred to in the previous article was said to have an output of approximately 125 watts, which meant that the output would be 125 watts with *sine wave* input. Of course, this output with the *sine wave* would only modulate a 250 watt input 100%. However, the 125 watts will modulate a 500 watt carrier input 70.7%, with *sine wave* input to the modulator. The percentage modulation on peaks should not be allowed to exceed 85%, which means that at voice frequencies the modulator would have to be driven only slightly harder to accomplish 85% modulation on voice

greater output in a given modulator is to raise the plate voltage and the load impedance into which the modulator is working. While some tubes having excellent insulation can be made to deliver a great deal more than twice the rated audio output with this method, the average plate dissipation with voice excitation, is still below the manufacturers' rating. This is borne out when we refer to some of the oscillograph records shown in the accompanying illustrations.

Undoubtedly there are many amateurs who are unfamiliar with the complexities of voice wave forms, and some of their very interesting points will be discussed in this article.

In Fig. 1, we find oscillograph recordings of the word "alters." The first line has to do with the first part of the word concerned with the letter "A." Next is for "L," next "T," next "ER," then "S" and the last one is a plain 500 cycle wave of the same maximum amplitude as the greatest peak appearing in the entire recording of the word "alters." The average power contained in the word "alters" is considerably less than the average in the 500 cycle wave form. This will prove point one in our discussion, that you can overload a class "B" amplifier on voice forms to a considerable extent, without ex-

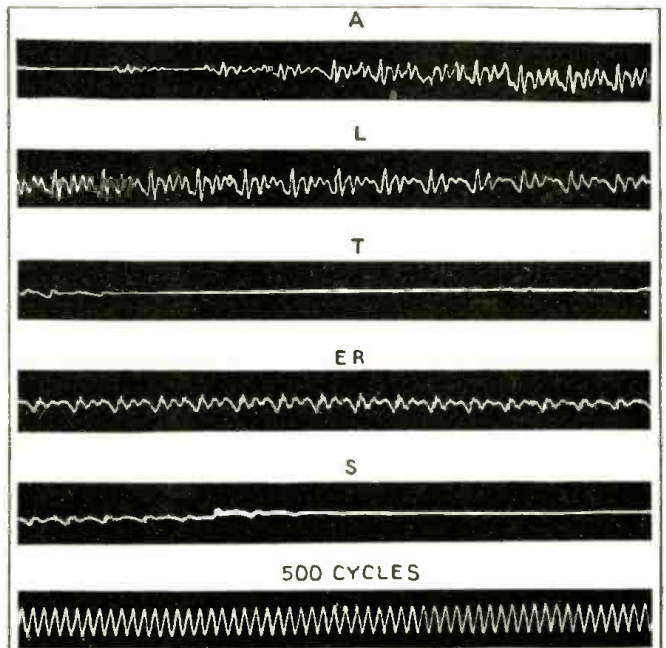

Courtesy of D. Van Nostrand Company, Inc.

Oscillograph of the word "alters," together with a 500 cycle wave. Fig. 1.

● Throughout this article it must be borne in mind that only class "B" modulators are considered, and also it must be borne in mind that the peak output of the modulator must be equal to the carrier input, and that the 25% value is concerned only with *sine wave* output of the modulator. The question is, will a modulator with a rated *sine wave* average output equal to 25% of the carrier input modulate the carrier fully with voice excitation? The answer is *yes* in the majority of cases, where good tubes and high grade equipment is employed! After several engineers of a world-famous tube manufacturer had read this article, this statement was made to the author:

"Tubes designed for Class B operation have a tremendous capability to handle instantaneous currents of very large magnitudes."

In a specific "test case" a pair of modulator tubes operated at the manufacturer's specified plate voltage and rated by the manufacturer to have an output of 130 watts, actually modulated a 500 watt input to the extent of 140%, as checked with accurate instruments designed and sold by leading engineering concerns. This test was made by Arthur H. Lynch, W2DKJ, well-known as a leading technical radio expert and active "Ham," in collaboration with W2CLA and W2GYL.

For the S-W Beginner

A Novel "Regen." 2-Tube

By Harry D. Hooton, W8KPX

This two-tube receiver has a novel regeneration control, with tickler in the screen-grid circuit. Smooth operation is obtained over the range of 9 to 270 meters. Band-spread is included; 6.3 or 2.5 volt tubes optional.



Rear view of set, showing plug-in coil and two tubes in place.

method. The author decided to try out a circuit in which the smoothness of the condenser regeneration control and the advantages of the electron-coupled detector were combined. The results were surprisingly good and the two-tube receiver that developed from the experiment is illustrated and described in this article.

Tickler in Screen-Grid Circuit

As the schematic diagram, Fig. 1, shows, the chief difference between this circuit and the conventional electron-coupled arrangement, is due to the fact that the tickler is placed directly in the screen-grid circuit *instead of the cathode lead*. The 100,000 ohm carbon resistor¹ serves a dual purpose inasmuch as it is used to block the R.F. currents and force them through the 250 mmf. regeneration condenser to its correct value. In case the screen voltage is obtained from a tap on the power-supply voltage-divider, an R.F. choke of about 2.5 mh. rating should be substituted for the resistor. The remainder of the circuit is more or less conventional, consisting of a single pentode audio amplifier resistance-capacity coupled to the plate of the detector tube.

Chassis and Panel Easily Made

This receiver, as the photographs and drawings show, is very small and compact, being built up on a 4½ x 9 inch chassis and a 7 x 10 inch panel. These are made from either electralloy or aluminum sheeting and are laid out, cut and drilled as shown in Fig. 2. Before the chassis is bent, make a cut with a pointed instrument along the dotted lines as shown. This will allow the side and ends of the chassis to bend square which gives a better appearance to the finished receiver. If the builder does not care to construct his own chassis, the manufactured type can be used. Small bases of approximately this size in both steel and electralloy construction are carried by most radio supply houses.

Layout of Parts

The arrangement of the various parts on the chassis and panel should be followed exactly if maximum results are to

1. A higher value of resistance will lower the screen voltage and permit greater sensitivity.



Front of receiver, with Cannon-ball head-phones. Yes, it has band-spread!

be obtained. The regeneration control is placed at the left of the tuning dial; the band-setting condenser is at the right directly underneath the detector tube socket where the "hot" leads to the coil and the grid circuits will be short and direct. The sockets for the two tubes and the coil are *not* placed underneath the chassis as is the usual custom, but are mounted above the metal base on ¼ inch brass bushings. This eliminates the labor of cutting the socket holes in the chassis and gives very short wiring between the sockets and the other parts of the set. The socket for the plug-in coils has been placed at the rear of the chassis as far away from the metal panel as possible. This is desirable because metal objects inside the coil field frequently cause considerable R.F. losses in small sets of this type. The antenna is coupled directly to the grid side of the tuned circuit through the small 35 mmf. trimmer condenser as shown at "1" in Fig. 1. The 6-prong Hammarlund coils have interwound primaries, however, and the coupling, especially if a doublet antenna is to be used, may be made as indicated by the figures "2" and "3" on the diagram.

Keep Wires Short

All wiring between the various parts of the circuit must be kept as short and direct as possible. Solder each connection carefully with a hot, clean (Continued on page 199)

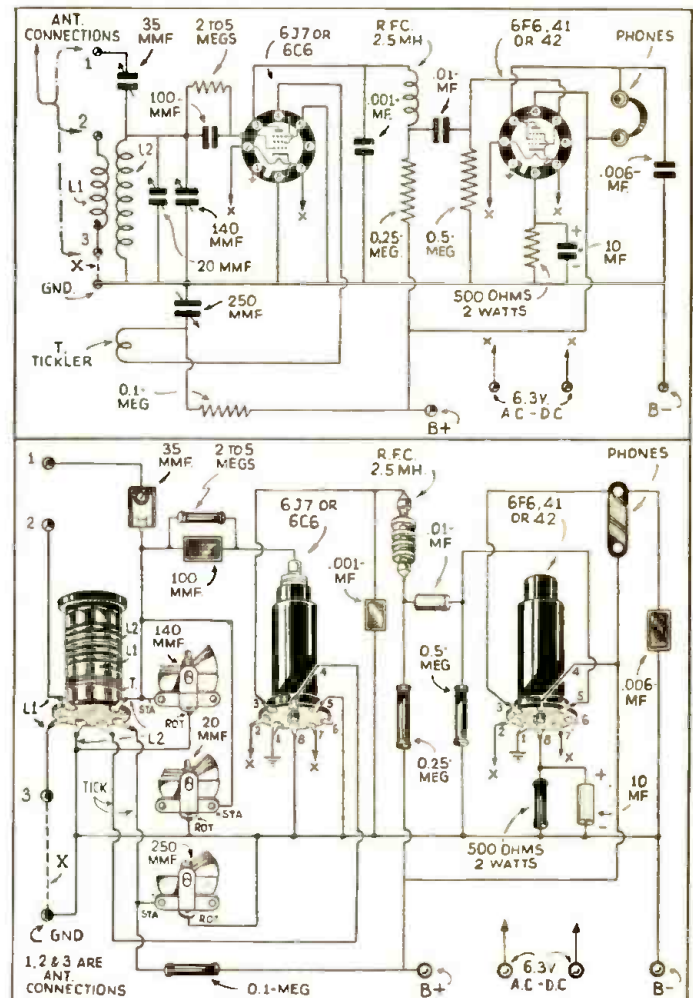

Hook-up of 2-tube regeneration receiver.

The "S.W. & T"



The author is shown operating the "S.W.&T." receiver—and, Boy! Does it perk!

● FOR a long time we have desired to build what we would call an ideal home-constructed receiver for amateur operation, incorporating all of the well-known desirable features together with a reasonable construction cost and one which was reasonably simple to construct and easy to get working.

Our first great problem was deciding between plug-in coils and band-switching arrangements. For really high efficiency, we do not believe it is possible for the home constructor to build a coil-switching arrangement which can compare with efficient plug-in coils; therefore, the best compromise was effected and the plug-in coils were made to

though complete data is given should the reader desire to try his hand at constructing them.

Regen. "Acorn" Detector Stage Solves Many Problems

The next problem was how much R.F. should be used ahead of the first detector. In order to determine this, considerable experimental work had to be done. We found that to do the job right, two stages of R.F. should be used. One stage would still permit a noticeable amount of image to get through. Then, also, we were sure that regeneration in the first detector would provide at least as much gain as would one stage of tuned radio frequency. However, regeneration usually brings about considerable noise. Having recalled the low noise-level of receivers employing acorn tubes, we decided to try a regenerative 954 acorn detector and eliminate *all* R.F. stages. This yielded remarkable results, the image rejection was as good, if not better than would have been obtained with conventional tubes and one stage of R.F., and the sensitivity was even better. Also the noise generated in the regenerative first detector was practically nil! Using this arrangement eliminated an extra tuning condenser and eliminated one plug-in coil, which is quite a saving inasmuch as the results are as good, if not much superior.

How Good AVC Action was Provided

Next was the problem of I.F. amplification and a method of attaining automatic volume control; immediately we decided that iron core I.F. transformers should be used, and it had been demonstrated long ago that one stage of I.F. was not entirely satisfactory, although very good results can be obtained with that arrangement, so two stages of amplification was decided upon. Efficient AVC meant incorporating at least another tube to get satisfactory results following conventional arrangements. This difficulty was overcome by employing two 6L7's in the I.F. stages with grids No. 1 and No. 3 connected in parallel insofar as AVC action is concerned, thus permitting very sharp cut-off, and the voltage developed in the diode second detector proved to be more than sufficient for excellent AVC action. In fact, we have yet to see a set using conventional AVC methods which worked any more satisfactorily than this one. As a means of checking signal strength and aiding tuning we employed a 0 to 5 ma. meter in the plate circuit of the first I.F. tube.

The second detector is a 6H6 duo-diode, one section being used for rectification, and the other as a *noise-limiter* in an effort to reduce ignition interference.

Beat Oscillator—Improved Type

In order to keep the number of tubes down, a twin triode was employed in the first stage of audio amplification, one section is used as an *audio amplifier*, while the other section is the *beat-oscillator*. This proved a wise step, inasmuch as the tube is always hot during operation and practically eliminated all creeping in this oscillator. The receiver can be operated for hours without the oscillator and when it is turned on it will be found to be right on the button! This

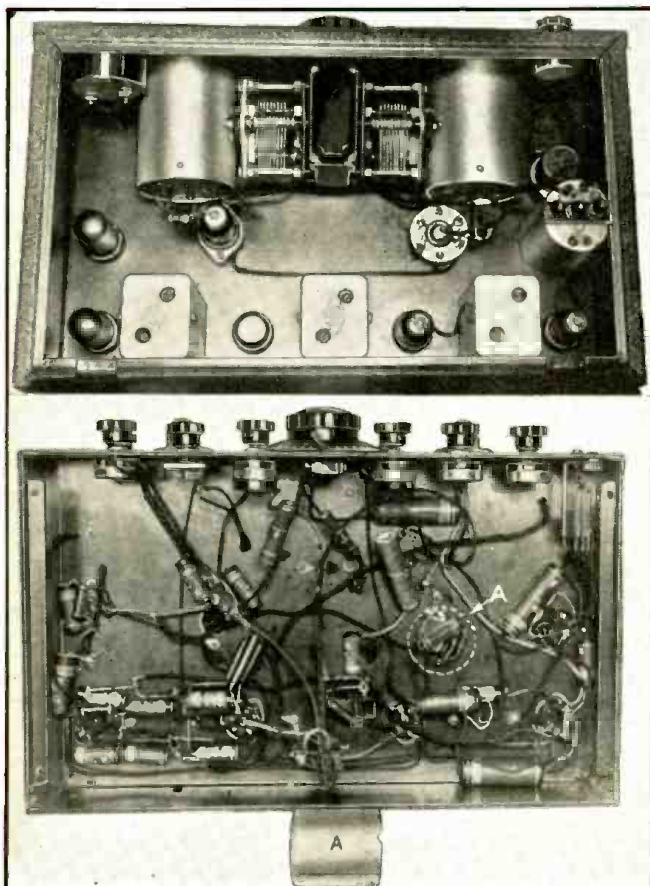

Top and bottom view of receiver showing construction and layout.

COMMUNICATIONS RECEIVER

By
George W. Shuart, W2AMN

Features

- Perfect band-spread
- Efficient AVC
- Ideal for phone operation
- Variable selectivity
- High sensitivity
- Regenerative "acorn" detector.

eliminates the necessity for a beat oscillator tuning control on the front panel; and in the two months during which this receiver has been operating, the beat oscillator adjustment has never been changed; merely set it for the most pleasing tone and forget about it.

The audio amplifier is a conventional 6F6 pentode with a phone jack between the two stages for earphone operation.

Trans-filter Affords Single-Signal Reception

In order to take care of the selectivity problem we employed the new Brush Transfilter, this permitted excellent selectivity in the phone bands and practical single-signal reception on CW. There is a control in the crystal circuit to change the band-width. How-



Front view of the receiver, the controls are as follows: A—First detector regeneration, B—Detector trimmer, C—R.F. gain and AVC switch, D—Beat oscillator switch, E—Noise silencer, F—A.F. volume control, G—Tone control, H—Crystal band-width control. The jack in the extreme right-hand corner is for ear-phone operation.

ever, it is left in the maximum selectivity position because even at this point it is not too selective for fair tone quality on phone signals. For band-spread tuning, of course, in a good receiver there is only one solution and that is the use of the National micrometer dial. This is really an ex-

cellent device and makes operating a real pleasure. Employing FB-7 band-spread coils, the amount of spread obtained with this combination can be gauged by the fact that the 80 meter CW band covers from 135 to 315 on the dial, while the 80 meter phone band takes in that (Continued on page 195)

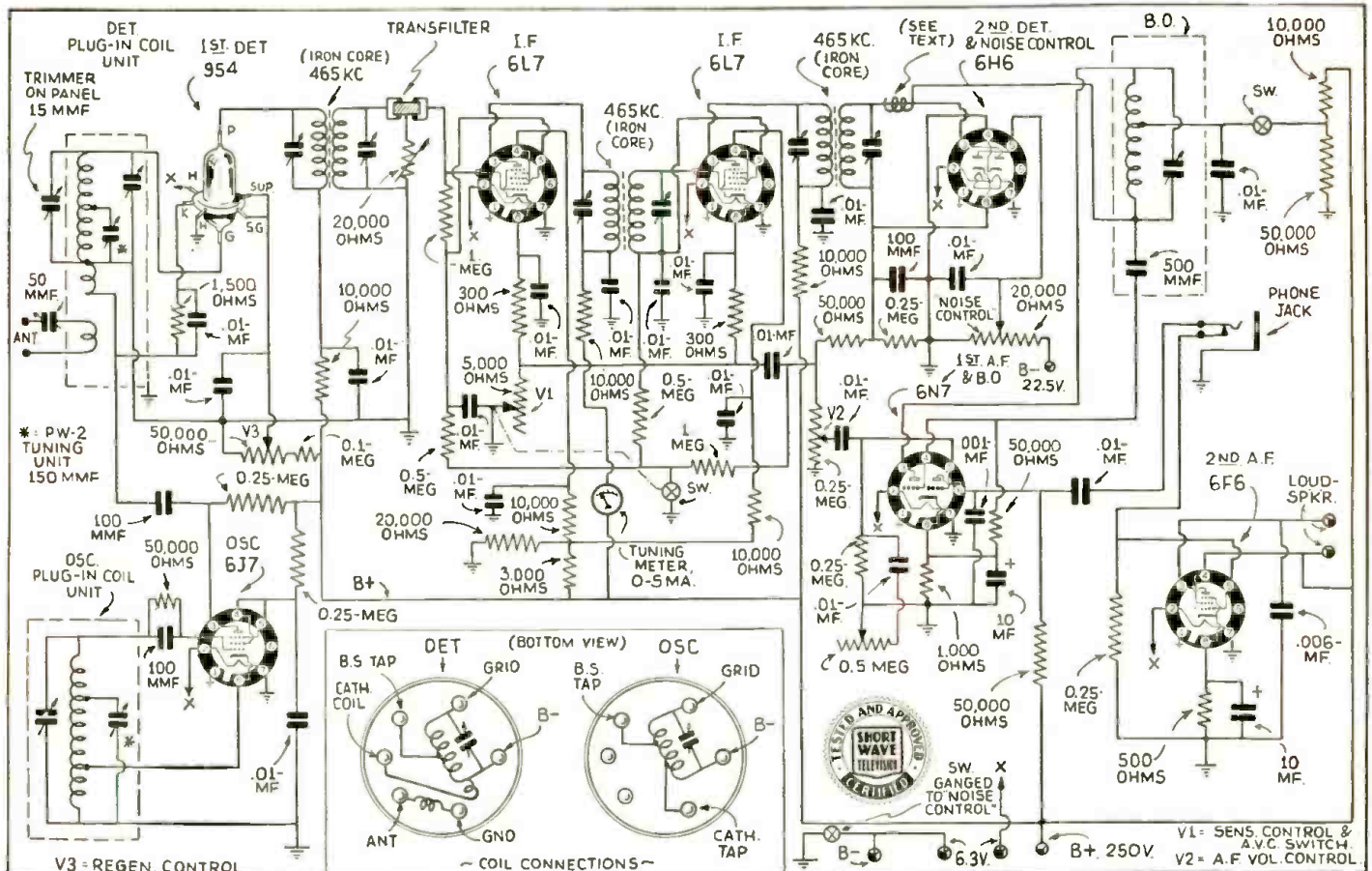

The complete schematic diagram of the "S.W.&T." Communications Receiver

The 5-40-400 Trans-

By Arthur H. Lynch, W2DKJ

● **ACTIVITY** on five and ten meters has been increasing so rapidly that we wanted to provide ourselves with a transmitter which would be reasonably efficient on both these frequencies and, at the same time, could be altered, without a great deal of trouble, to provide satisfaction on some of the lower frequency bands such as twenty and forty meters. In casting about for a suitable oscillator circuit our attention was called to several different types, each of which seemed to offer desirable characteristics, not found in the others. In order to satisfy our own curiosity, we decided, if it were easy to provide ourselves with a transmitter which would make it possible to change from one type of oscillator circuit to another without a great deal of trouble.

"Long Lines" Oscillator Employed

Ever since the "long lines" oscillator was popularized by George Shuart, W2AMN, we have found the application of this type of circuit to be a simple mechanical job and a fairly efficient electrical arrangement. So, when it came time to consider a suitable ar-

High Efficiency At Reasonably High Power—Even On Five Meters—Is Accomplished By This Novel Transmitter. It Incorporates Several Interesting Features Which Make It Comparatively Easy To Build And Operate. The Range Of The Set Is 5 To 40 Meters. And Up To 400 Watts Input. This Is The First Of A Series Of Three Articles.

range for running relatively high-powered tubes on five meters, we discussed the possibility of using "lines" in the final stage of our transmitter with Edwin Ruth, 3rd, W2GYL, chairman Technical Committee of the Garden City Radio Club, and with Harry Lawson, W2IER, who built the unit for us. We delineated our ideas as to how the "lines" should be made and our reasons why they would be satisfactory, and no objection could be found to them.

Of course, in the development of a "rig" for operation on five meters, particularly when reasonably high power is to be used, a selection of suitable components for the final stage is a matter of no small importance. We have no idea that the arrangement we are about to describe is the best that can be found, but we do know that it is very satisfactory; some indication of the effi-

ciency at which the final stage is functioning may be gleaned from the fact that the plate current in the push-pull RK-38's, used in this stage, is below forty ma. (m.a.) when the final stage is unloaded and it runs two-hundred ma. with the normal four-hundred

watt load for which the transmitter has been designed. It can be run up to more than five hundred watts, without any noticeable distortion or other ill effects resulting from the mis-match of impedance which this overload condition brings about.

Every attempt has been made to operate the tubes in the entire radio-frequency unit well within the rating limits specified by the manufacturers. Two important reasons for this type of operation are a really noticeable extension of tube life, as well as avoiding the generation of harmonics, which always follows the operation of tubes at the limit of their capability.

It must be understood that this type of transmitter is most certainly not the kind of equipment that should be contemplated by the novice. All the information necessary for the experienced

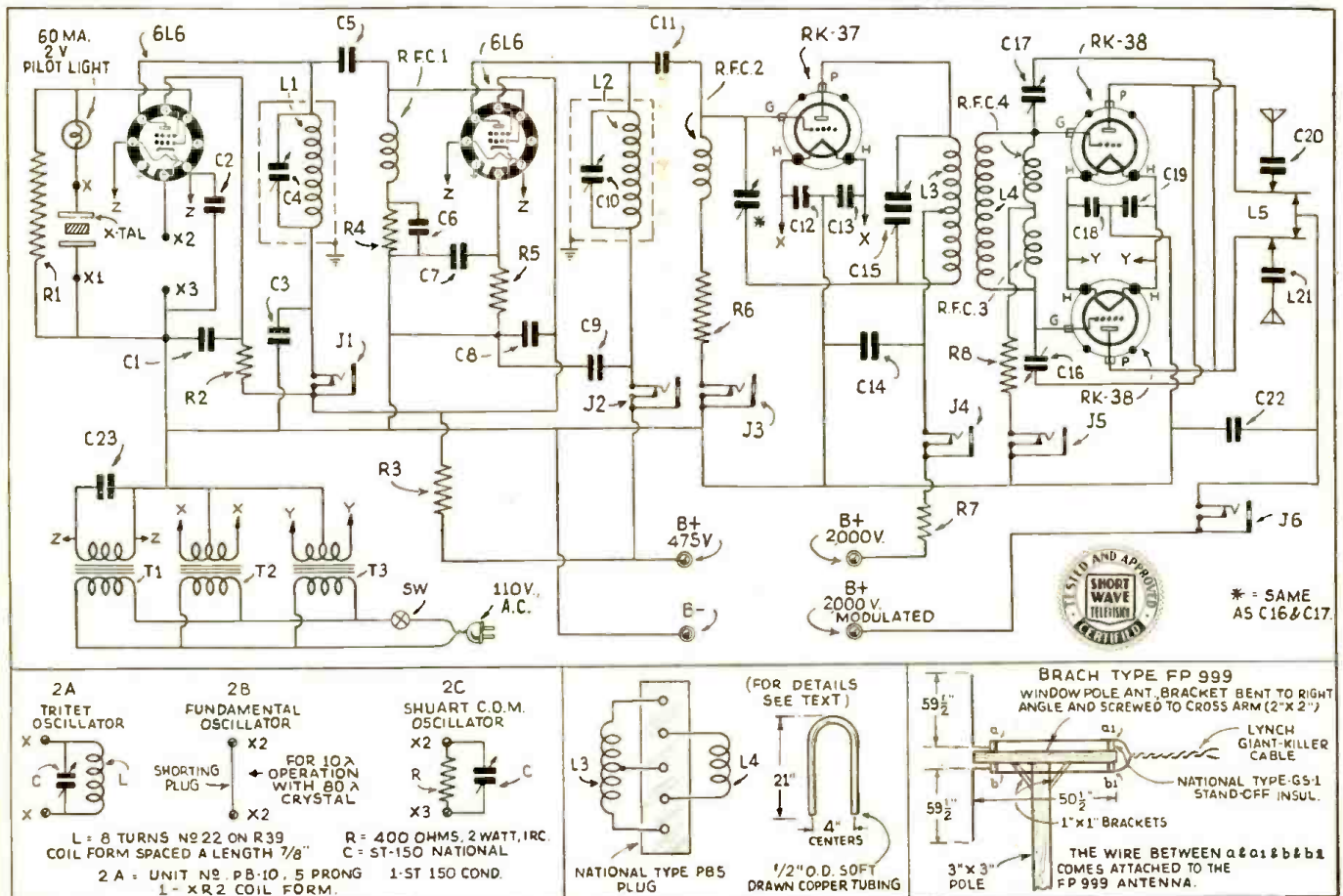

Wiring Diagram of Transmitter. The RK37 neutralizing condenser is not needed for 5 meter operation.

mitter



constructor to duplicate a transmitter of this nature, will be found in the accompanying illustrations. No definite layout drawings have been provided because the experienced constructor may have certain ideas regarding the layout which he will want to incorporate in the finished unit.

Circuit Quite Orthodox

From the plate circuit of the 6L6, which is used in the oscillator, to the grid circuits of the push-pull RK-38's, used in the final stage, the circuit shown in figure 1 is absolutely orthodox and requires nothing more than passing mention. Reference to Figure 2 will disclose that there are two unfilled sockets in the upper left-hand corner of the illustration. The only active portion of these sockets is indicated by the lines surrounding the two socket holes in each case. The holes marked "X" and "X1" correspond to the markings in Figure 1 and they are used for the mounting of the crystal. It will be observed that if a variable crystal, such as the National type CHV, is employed, the five prongs, with which the crystal holder is provided, will fit right into the upper left-hand socket. The circuit arrangement is such that a variable crystal of this nature, designed for operation in the forty meter band, may be used very effectively in this transmitter, even when ten meter operation is desired.

The two additional apertures, in the second sockets, marked "X2" and "X3" make it possible to use either the fundamental oscillator type of circuit, such as would be used with the variable crystal, or by employing the circuit shown in Figure 2-A. It is possible to use the Tritet Oscillator, or, with the arrangement shown in 2-C, provision is automatically made for

using the Shuart "C-O-M" type of Crystal-Oscillator-Multiplier.

So much has been said about Tritets that additional reference to that type of oscillator is unnecessary and full information

The 5-40-100 Crystal-Control Transmitter As Seen from the Front.—The two sockets shown on the left-hand corner of the chassis have not been placed there in error, but they are used for so many different purposes that the author considered it desirable to show them blank, so as to more fully cover their usefulness in the text. The round hole in the front of the chassis and the oblong well in the upper surface have been provided purposely, and they are used when it is desired to operate the transmitter on some of the lower frequencies. The manner in which they are used will be the subject of another article.



concerning the C-O-M type of oscillator will be found in Mr. Shuart's own article in the May (1937) number of *Short Wave and Television*.

The arrangement illustrated, in connection with this description, is, primarily, for operation on five meters, and the necessary mechanical variations for operation on ten meters will be the subject of a future description. Reference to the dotted lines surrounding the combination C-4 and L-1 and C-10 and L-2 merely indicate that the condensers

The under portion of the Radio Frequency Chassis—It will be noted that some of the voltage-dropping resistors, as well as all of the filament transformers for supplying the radio-frequency portion of the transmitter, are mounted under this "deck."



The Operating Shack at W2DKJ—The 5-40-100 Transmitter with its "power-supply" is shown on the small table, directly in front of the author. The Modulator and National Midget Oscilloscope are shown to the left. The low-impedance cables draped above the author's head run to the antenna relay which is on the other side of the window shade. The National NC-100X receiver is used on the ten and other lower frequency bands while for five meter operation a National 1-10 receiver has proved to be most satisfactory, after many other types of receivers were tested. It will be observed that Mr. Lynch favors a Crystal Microphone.

and inductances represented by these figures are mounted and enclosed in the regular National FXTB Plug-in Fixed Tuned Exciter Tanks.

Details of Plate Rods

A word or two may be worth while in connection with the plate rods in the final stage. It will be observed that the layout is such that the plate leads connecting the lower extremities of the plate rods and the plate connection on the RK-38 tubes are extremely short, as are the leads from the National NC-800 Neutralizing condensers, employed in this final stage. The 4-GS3 insulators supporting the plate leads are provided with Giant plug-in jacks and the lower extremities of the rods are provided with Giant plugs to match these jacks. Ordinary banana plugs are not suitable for this use, when any such power as 400 watts is being considered. Of course, a layout of the same general nature would be suitable for operation on lower power and it would be but necessary to change the tube line-up and the voltage supplied to the various portions of the circuit. The bending of the plate rods was accomplished by running a cork fairly well up into the tube; filling the central portion with moist sand, applying another cork to the other end so as to prevent the sand from oozing out and then bending the tube around a metal lally column. A round wood pole of suitable diameter would serve equally well for this bending process. It is desirable to run a reasonably strong cord through the corks so that they may be withdrawn after the bending process is completed. The sand is removed from the tubing by simply introducing running water. It will be seen that a very simple method for coupling the antenna to the plate rods

(Continued on page 203)

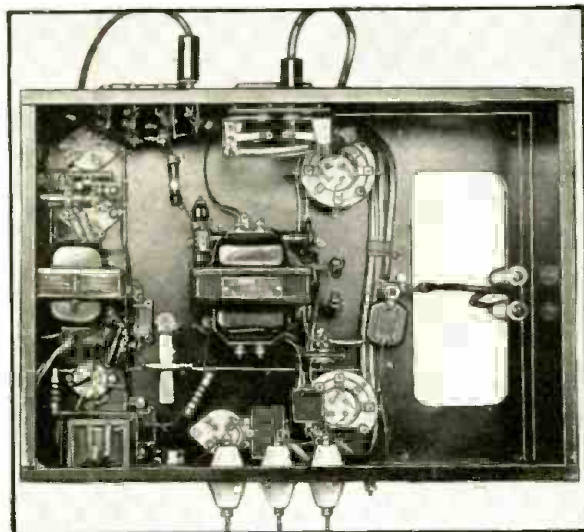

SHORT WAVE SCOUTS

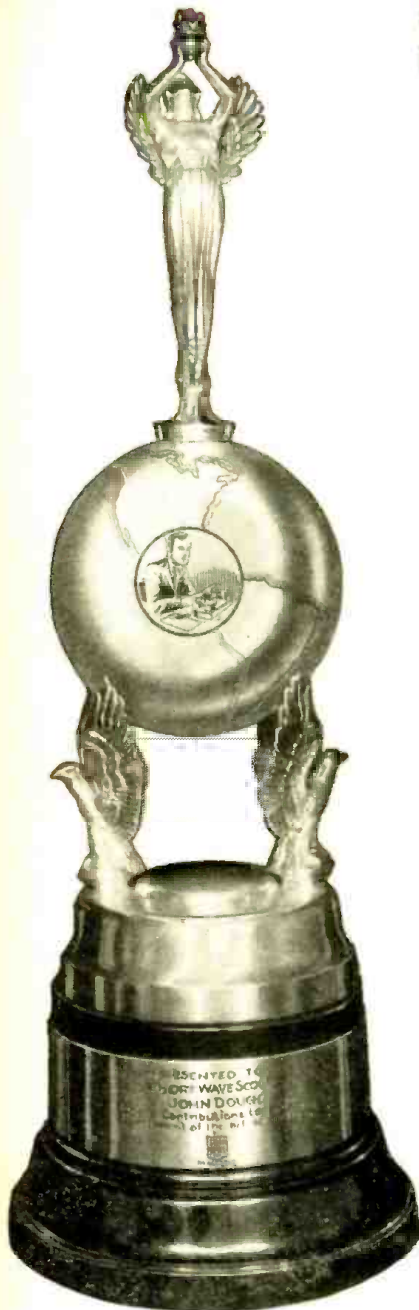

FORTIETH TROPHY

Presented to
SHORT WAVE SCOUT
ROBERT CHASE
 231 Henry Street
 New York, New York

103 Stations—88 Foreign
 For his contribution toward the
 advancement of the art of Radio



HONORABLE MENTION

William Elliott
 New York, New York
 Arthur Nugent
 Flat Rock, Indiana

Mr. Chase further states that it required plenty of patience to stay at the receiver hunting for the elusive DX stations. His antenna is 50 ft. long, and 60 ft. from the ground and is a straight flat-top affair, running NNE by SSW. Being located on the sixth floor of the building, the antenna required no downward lead-in. He said one of the greatest thrills was the QSL from EAQ, because the day the station was received, Madrid was in the middle of a very heavy artillery bombardment and the announcer remarked that "it is possible that we may be blown up any minute!" Congratulations, Mr. Chase, and we think that you really did a wonderful job, despite a few obstacles.

Mr. Chase's Short-Wave Station "Log"

- United States
- W1XAL, 6040 kc., University Club, Boston, Mass.
 - W1XAL, 11790 kc., University Club, Boston, Mass.
 - W2XHG, 41000 kc., N.B.C. Radio City, New York, N.Y.
 - W2XDV, 38600 kc., C.B.S., New York, N.Y.
 - W2NE, 11830 kc., C.B.S., New York, N.Y.
 - W2XAD, 15330 kc., General Electric, Schenectady, N.Y.
 - W2XAF, 9530 kc., General Electric, Schenectady, N.Y.
 - W3XAL, 17780 kc., N.B.C., Radio City, New York, N.Y.
 - W3XAL, 6100 kc., N.B.C., Radio City, New York, N.Y.
 - W3XAU, 6060 kc., Philadelphia, Pa.
 - W3XAU, 9590 kc., Philadelphia, Pa.
 - W8NAL, 6060 kc., Crosley Radio Corp., Cincinnati, Ohio.
 - W9XF, 6100 kc., N.B.C., Chicago, Ill.
 - W9XAA, 6080 kc., Chicago, Ill.
 - W9XAA, 11830 kc., Chicago, Ill.

Canada

- VE9DN, 6005 kc., Canadian Marconi Co., Montreal, Que.
- CFCX, 6005 kc., Canadian Marconi Co., Montreal, Que.
- CJRO, 6150 kc., James Richardson & Sons Ltd., Winnipeg, Man.
- CJRX, 11720 kc., James Richardson & Sons Ltd., Winnipeg, Man.

Mexico

- XECR, 7380 kc., Foreign Office, Mexico, D.F.
- XEFT, 9510 kc., La Voz de Veracruz, Veracruz, Mexico.

- XEUW, 6020 kc., Veracruz, Mexico. English calls.
- XEWI, 11900 kc., P. O. Box 2874, Mexico, D.F.
- XEME, 8190 kc., La Voz de Yucatan desde Merida, Merida, Yucatan, Mexico.
- XEBT, 6000 kc., P. O. Box 7944, Mexico, D.F.

Cuba

- COCO, 6010 kc., P. O. Box 98, Havana, Cuba.
- COKG, 6200 kc., P. O. Box 137, Santiago, Cuba.
- COCD, 6130 kc., P. O. Box 2294, Havana, Cuba.
- COCH, 9428 kc., General Broadcasting Co., Havana, Cuba.

Central and South America

- YNOP, 5758 kc., Radiodifusora Bayer, Managua, Nicaragua.
- TGWA, 9450 kc., Radiodifusora Nacional, Guatemala City, Guatemala.
- TG2X, 5940 kc., National Police, Guatemala City, Guatemala. English programs.
- HP5B, 6030 kc., P. O. Box 910, Panama City, R.P.
- HP5J, 9590 kc., La Voz de Panama, P. O. Box 867, Panama City, R.P.
- HP5K, 6005 kc., La Voz de la Victor, P. O. Box 33, Colon, R.P.
- HI7P, 6800 kc., Diario del Comercio, Ciudad Trujillo, R.D.
- HI3U, 6015 kc., La Voz de Comercio, Santiago, R.D.
- HIT, 6630 kc., The Voice of RCA-Victor, P. O. Box 1105, Ciudad Trujillo, R.D.
- HIH, 6780 kc., La Voz del Higuanu, San Pedro de Macoris, R.D.
- HIN, 6243 kc., La Voz del Partido Dominicano, Ciudad Trujillo, R.D.
- HI1S, 6420 kc., La Voz de la Hispaniola, Santiago, R.D.
- HI1A, 6150 kc., La Voz del Yaque, P. O. Box 423, Santiago, R.D.
- HI1X, 6340 kc., Estacion Radiodifusora HIX, Ciudad Trujillo, R.D.
- HI1J, 5865 kc., P. O. Box 204, San Pedro de Macoris, R.D.
- TI8WS, 7550 kc., Ecos del Pacifico, P. O. Box 75, Puntarenas, Costa Rica.
- TI4NRH, 9670 kc., The Voice of Costa Rica, P. O. Box 40, Heredia, Costa Rica.
- HH2S, 5910 kc., Societe Haitienne de Radiodiffusion, Port-au-Prince, Haiti.
- VP3MR, 6010 kc., The Voice of Guiana, Georgetown, British Guiana, S.A.
- PRF5, 9501 kc., P. O. Box 709, Rio de Janeiro, Brazil.
- OAX4G, 6230 kc., Apartado 1242, Lima, Peru.
- LRX, 9660 kc., Radio El Mundo, Calle Maipu, 555, Buenos Aires, Argentina.
- LRU, 15280 kc., Radio El Mundo, Same as above.
- LSX, 10350 kc., Transradio Internacional, San Martin 329, Buenos Aires, Argentina.
- HC2CW, 8404 kc., Ondas del Pacifico, Guayaquil, Ecuador.
- HC2RL, 6670 kc., P. O. Box 759, Guayaquil, Ecuador.
- HC2JSE, 7854 kc., Ecuador Radio, Guayaquil, Ecuador.
- HJ4ABU, 6150 kc., La Voz de Pereira, Pereira-Caldas, Colombia.
- HJN, 5950 kc., Ministerio de Educacion Nacional, Bogota, Colombia.
- HJ4ABH, 9520 kc., La Voz de Armenia, Armenia, Colombia.
- HJ4ABP, 6030 kc., Emisora "Philco," Medellin, Colombia.
- HJU, 9510 kc., La Voz del Pacifico, Buenaventura, Colombia.
- HJ3ABD, 6050 kc., Colombia Broadcasting S.A., Bogota, Colombia.
- HJ1ABP, 9600 kc., Radiodifusora Cartagena, P. O. Box 37, Cartagena, Colombia.
- YV6RV, 6520 kc., La Voz de Carabobo, Valencia, Venezuela.
- YV1RG, 6230 kc., Radio Valera, Valera, Venezuela.
- YV5RMO, 5850 kc., Ecos del Zulia, Maracaibo, Venezuela.
- YV9RC, 6400 kc., Ondas Populares, P. O. Box 1931, Caracas, Venezuela.
- YV1RH, 6360 kc., Ondas del Lagos, P. O. Box 261, Maracaibo, Venezuela.
- YV3RC, 6150 kc., Radiodifusora Venezuela, Caracas, Venezuela.
- YV5RP, 6270 kc., La Voz de la Philco, Apartado 508, Caracas, Venezuela.
- YV5RC, 5800 kc., Radio Caracas, Caracas, Venezuela.
- PRADO, 6625 kc., Apartado 98, Riobamba, Ecuador.
- HRD, 6235 kc., La Voz de Atlantida, La Ceiba, Honduras.

(Continued on page 202)

● ON this page is illustrated the handsome trophy which was designed by one of New York's leading silversmiths. It is made of metal throughout, except the base, which is made of handsome black Bakelite. The metal itself is quadruple silver-plated, in the usual manner of all trophies today.

It is a most imposing piece of work, and stands from tip to base 22 1/2". The diameter of the base is 7 3/4". The diameter of the globe is 5 1/4". The work throughout is first-class, and no money has been spared in its execution. It will enhance any home, and will be admired by everyone who sees it.

The trophy will be awarded every month, and the winner will be announced in the following issue of SHORT WAVE & TELEVISION. The winner's name will be hand engraved on the trophy.

The purpose of this contest is to advance the art of radio by "logging" as many short-wave phone stations, amateurs excluded, in a period not exceeding 30 days, as possible by any one contestant. The trophy will be awarded to that SHORT WAVE SCOUT who has logged the greatest number of short-wave stations during any 30-day period.

● Despite many handicaps, Mr. Chase came through in excellent style. A total of 103 stations, 88 foreign is surely an excellent one. In his letter, Mr. Chase states that he used an Ultra High Frequency Products Co., Model 5-T receiver; an A.C.-D.C. affair, with a tuning range of 1 1/2 to 600 meters. He lives in a D.C. district in downtown New York City, and from many years of experience in short waves he states that he is satisfied that his location is an exceptionally noisy one.

**\$5.00 PRIZE
SIMPLIFYING ANTENNA
CONSTRUCTION**

The following kink may be of interest to five-meter "hams." It is a method of

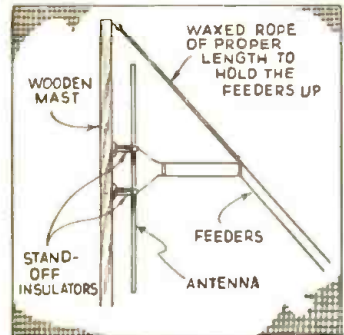

supporting the feeders to a two-wire matched impedance antenna of the vertical type. Those of us who have had any experience with such feeder systems know the difficulty of supporting the customary cross-arm on the vertical pole. The diagram will make clear the idea that I have in mind. Since the feeders exert a pull tangent to the mast, the rope is all that is necessary to insure against swinging. I trust that this idea will meet with your approval.—Maxwell Hillin, W2GEN.

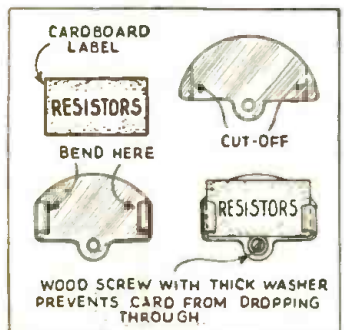

**SAVE OLD CONDENSER
PLATES**

A use for old condenser plates is to make holders (or brackets) in which a card is placed, designating the contents of drawer or container. I have them on the front of all my drawers, cupboards, and sliding boxes in my "shack." I have my parts segregated and labeled, which eliminates lots of hunting and saves time.—John T. Kelly.

PHONE JACK

The sketch shows a method which automatically connects the ear-phones to the speaker output. This is an addition to your

**\$5.00 FOR BEST
SHORT-WAVE KINK**

The Editor will award a five dollar prize each month for the best short-wave kink submitted by our readers. All other kinks accepted and published will be awarded eight months' subscription to **SHORT WAVE & TELEVISION**. Look over these "kinks"; they will give you some idea of what the editors are looking for. Send a typewritten or ink description, with sketch, of your favorite short-wave kink to the "Kink" Editor, **SHORT WAVE & TELEVISION**.

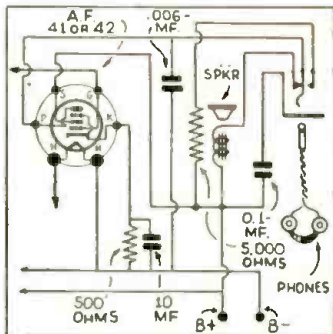
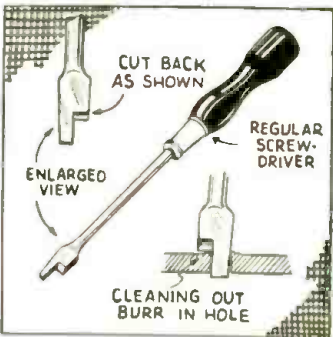
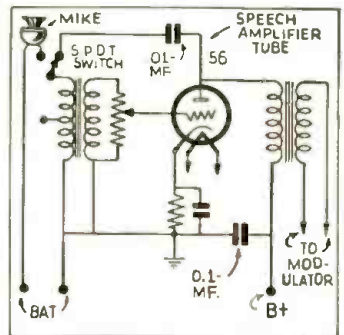

diagram of the "Multi-Band 2" receiver shown in the May issue of **Short Wave & Television**. When the phone plug is inserted in the three-circuit jack (which is insulated from the chassis) it disconnects the speaker from the circuit and, at the same time, connects the 5,000 ohm resistance across the speaker terminals; and the 0.1 mf. condenser in series with the phones. I have built the "Multi-Band 2" and it surely works fine.—L. G. Saunders.



BUR REMOVER

This tool is made from an ordinary common screw-driver, with the end filed down on one side, only it is filed on a slant. I invented this tool for removing the burrs that are found around a hole after being drilled, especially in aluminum. If the small end is put down in the hole and pressed tightly, then turned around two or three times, it will take the burrs off as clean as a whistle. This is a simple tool made from a common screw-driver which may be found anywhere. To give my own private opinion of this, I think it is one of the "most useful" radio tools I ever had around when drilling holes in panels for radios.—Frank West.



**GOOD FOR 5-METER
TRANSMITTERS**

In Radio Frequency Transmitters employing a microphone and microphone transformer in conjunction with a speech-amplifier tube preceding the modulator, the use of a condenser of suitable size and a 3-SPDT switch will produce tone-modulated telegraphy, thus making the transmitter versatile without the addition of separate Audio-Oscillators. The variable resistor normally used to control "gain" is also used in the I.C.W. switch position to vary the tone or frequency of the audio oscillations.

tions generated. There will be a definite increase in antenna current for different settings of the gain control, due to an approximate impedance match of all components at that particular audio frequency. The diagram shows the wiring for this service.—H. F. Beane, Mountain Lakes, N. J.

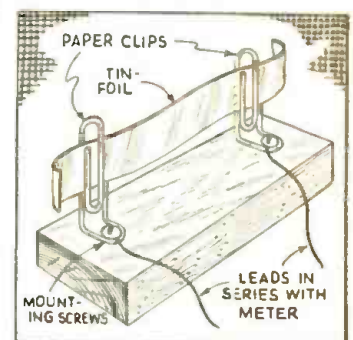

SAVING METERS

Good meters are expensive, and the amateur is often apt to ruin them in his experiments. It is a simple matter to protect them by the use of a fuse consisting of a small piece of tinfoil fastened between two small paper clips mounted in an upright position. Any piece of tinfoil can be used by cutting it to the right size.—J. W. Watson.

**METAL LATH FOR
SCREENING TRANS-
MITTER**

Most of us are familiar with the metal lath used by builders. This material is very reasonably priced and can be used by amateurs for screening apparatus, such as transmitters. In order to remove the danger element, beside being a precautionary measure, it also dresses up the transmitter. The drawing clearly shows the design of the lath and also how it is employed. This material is obtainable from any one of your local building material supply houses.—Del Tamper.

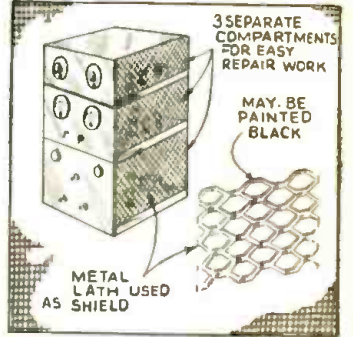

● WE are receiving fewer and fewer GOOD Kinks, and entirely too much DUPLICATION! Remember, this page depends upon contributions. If you boys do not send in some "good" Kinks in short order, you will lose a very valuable department. We receive hundreds of Kinks every day, many of which duplicate those which have already appeared on this page and many are "copied" from other magazines! So what say, let's hear from you!—Ed.

W. S. Paley Makes First Amateur Award

● WILLIAM S. PALEY, president of the Columbia Broadcasting System, on May 24th, presented the first annual Paley Amateur Radio Award to Walter Stiles, Jr., of Coudersport, Pa., for valiant service rendered during the March 1936 flood emergency in the Allegheny River valley.

At the presentation luncheon in the Waldorf-Astoria hotel in New York City, Anning S. Prall, chairman of the Federal Communications Com-

vania Railroad, was chosen for the first William S. Paley Amateur Radio Award by a board of judges comprising Rear Admiral Cary T. Grayson, chairman of the American Red Cross; the Hon. C. P. Edwards, Director of Radio for the Canada (Continued on page 201)

At left—The handsome trophy awarded to Walter Stiles, Jr., by William S. Paley, President of CBS

mission, joined Mr. Paley in paying glowing tribute to Stiles and to the 47,000 amateur operators in this country and Canada for the public service they perform in times of national emergency.

Kenneth B. Warner, executive secretary of the American Radio Relay League, spoke on behalf of his organization in accepting permanent custodianship of the trophy symbolizing the award to Stiles. A smaller size replica of the trophy was awarded to Mr. Stiles to keep permanently. The speakers were heard over a nation-wide network of the Columbia Broadcasting System.

Stiles, a 24-year-old employee of the Pennsyl-



Left—Walter Stiles, Jr. Right—William S. Paley.

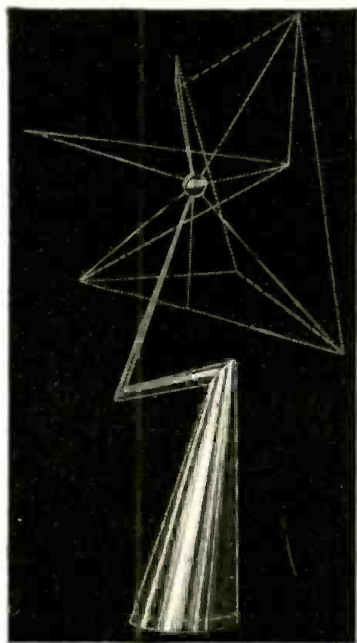

Let's "Listen In" With

Joe Miller

**Our Short Wave
"DX" Editor**

Winner of 30th "S-IV Scout" Trophy



Joe Miller "listening in" with the Hammarlund "Super Pro."

● OUR subject for this month's discussion concerns the large numbers of DXers who are tending to tune the amateur phone bands, to the exclusion of all other DX which may be heard. When we started DXing a few years back, the amateur bands were quite popular, and most every DXer ran over them in the course of his dial twisting, to see what the boys were working. In those days, however, the bands did not supply enough activity in the way of phone DX to hold the DXer's interest to the exclusion of all else. Nowadays, however, there is so much "popping up" on 10-20-40 and even 75 meter phones that many DXers prefer to do

certainly is entertaining in its precise calibration, for if one wanted to hear, say, XGOX, one merely had to tune to 6.87 mc. between 5:30-7:30 a.m., E.S.T., here in the East, and in would come this supposedly rare Chinese station. Needless to say such a receiver would make it simple for any mere beginner to "log" many a fine catch. Therefore our advice is, if you cannot afford such a receiver as the Super Pro, learn your dial thoroughly and it will pay you big dividends in the many fine "veris" you will earn by your greater DX skill. You can easily log many excellent DX catches that are on practically every day, if you only know what you are hearing, through

identification by your dial reading, if you have calibrated your dial. DX for the past month (May) has been uneventful and only the average run of DX has been heard. Throughout the summer months, our comments will be more on the amateur DX, as these are the main source of DX interest in the warm weather. of the Xmtr used by the Eclipse Expedition, and "logged" here on 17.31 mc. while located at the Enderbury Island, in the Phoenix group, roughly about 1,800 miles southwest of Hawaii, in the Pacific Ocean. Surprisingly, WMEF came in with a powerful signal, ranging from a R7-9 despite the late time of logging, 8:30 p.m., E.S.T., for such a high frequency. The program was relayed by KKP, 16.04 mc., Kauhuku, Hawaii, to KWO, 15.41 mc., Dixon, Calif., and could be heard excellently on all three stations at the same time. Unusually FB DX conditions prevailed, with all stations on the higher frequencies just "tearing in," so this might explain WMEF's extraordinary signal here in New York. Ashley Walcott also heard WMEF, aboard the "Avocet," when anchored off Canton Island, and adds that WMEF is with the U. S. Navy-National Geographic Society Expedition to observe the total eclipse of the sun in June. Joe Hellman and Russ Ballard also heard WMEF, Russ hearing WMEF sign off at 9:30 p.m., giving the freq. as 17.31 mc.

TUNIS

BIZERTE

TUNISIE

Atique du Nord

Laz 37-16 30' N - Long 9-52 00' E C

vous remercie pour le compte rendu d'écoute concernant ses émissions

Poste Bizerte—A real "Scoop"! Did you hear him?

all their tuning on these crowded bands, and leave the rest to the other fellow. One big reason for this attitude is in the unwillingness of many beginners in DX to learn their dials, i.e., to tune all over the dials and know what station they are hearing, by properly calibrating their receiver. There are many DXers who own superhets with calibrated dial readings, but in general these dials are a bit off here or there and calibration is unreliable. If everyone owned a superhet that was calibrated 100% perfect there would not be such a "tuning jam" on the amateur bands, as a DXer could run across the dial and when a signal was heard, read its exact frequency on the dial, and by the help of a good station list, properly identify the signal heard. Of course, it is far too much to expect, but if every one owned such a receiver as the Hammarlund Super Pro, our belief is firm that there would be much more general tuning and less concentration of the DXer's interest in the amateur bands. This FB DX receiver shown in photo above with "Ye DX Ed" at the controls,

a few months ago, and reception with a plain but distinctive QSL in just one month's time. This station is reported to be on the air from 3-5 p.m. on both 6.15 mc. and 12.32 mc., but we doubt if both waves would be used at the same time. The QSL is shown in this month's article, but the top letters spelling TUNIS are our own idea. The QRA of Poste Bizerte is: Amicale du Poste Bizerte, 14 Rue Hersent, Bizerte, Tunis. **ECLIPSE EX-PEDITION**
WMEF is the call

ZU6P—Here's that QSL all the boys will eventually get, we hope.

INDO-CHINA

Ashley Walcott, San Francisco, who hears the Asiatics as we here in the East hear Europe, reports much Asiatic activity during the past month. Ashley reports the Saigon "broadcaster" known as Philco Radio now using two frequencies simultaneously, 11.72 and 5.985 mc. This station has been "on the jump" roaming from 11.705 up to 11.75 mc. and from 5.945 to 6.055 mc., so we can only suggest that when tuning for Saigon, that you tune the span given for each freq. Lately English announcements are given, the Philco engineer who built the station, P. C. Brown, identifying the station as "Philco Radio Saigon" and stating the frequencies used as 11.71 and 6.01 mc., reports requested to be sent to P. O. Box 295 Saigon. Usually French announcements prevail, spoken by a woman who announces "Ici Station Boy-Landry, Rue Cantinat, Saigon." Preceding identification (Continued on page 200)

RADIO *Joe Miller*
FONE WAFB, on
KELT FET

QRM _____
QSB _____
QTH _____
QRP _____
QRT _____
QST _____
QSO _____
QTH _____
QRP _____
QRT _____
QST _____

Received _____
Freq _____
Call _____

W. F. MEYER
24 Madison Street
Hartford, Conn.

ZU6P

6P

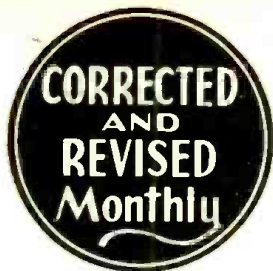

World S-W Station List

Complete List of Broadcast, and Telephone Stations

All the stations in this list use telephone transmission of some kind. Note: Station calls printed in bold face are broadcast stations; others are telephone stations.

Please write to us about any new stations or other important data that you learn through announcements over the air or correspondence with the stations.

↓ S.W. BROADCAST BAND ↓

Mc.	Call	
31.600	W3XEY	BALTIMORE, MD. , 9.494 m., Relays WFBR 4 pm-12m.
31.600	W2XDV	NEW YORK CITY , 9.494 m., Addr. Col. Broad. System, 485 Madison Ave. Daily 5-10 pm.; Sat. and Sun. 12.30-5, 6-9 pm.
31.600	W4XCA	MEMPHIS, TENN. , 9.494 m., Addr. Memphis Commercial Appeal. Relays WMC.
31.600	W8XAI	ROCHESTER, N. Y. , 9.494 m., Addr. Stromberg Carlson Co. Relays WHAM 7.30-12.05 am.
31.600	W8XWJ	DETROIT, MICH. , 9.494 m., Addr. Evening News Ass'n. Relays WWJ 6-12.30 am., Sun. 8 am.-12 m.
31.600	W9XPD	ST. LOUIS, MO. , 9.494 m., Addr. Pulitzer Pub. Co. Relays KSD.
26.100	GSK	DAVENTRY, ENG. , 11.49 m., Addr. B. B. C., London. Operates irregularly 5.45-8.55 am., 9.55 am.-12 n.
25.950	W6XKG	LOS ANGELES, CAL. , 11.56 m., Addr. B. S. McGlashan. Wash. Blvd. at Oak St. Relays KGFJ 24 hours daily.
24.600	W9XAZ	MILWAUKEE, WIS. , 12.19 m., Addr. The Journal Co. Relays WTMJ from 1 pm.
21.550	GST	DAVENTRY, ENG. , 13.92 m., Addr. (See 26.100 mc.) Irregular at present.
21.540	W8XK'	PITTSBURGH, PA. , 13.93 m., Addr. Grant Bldg. Relays KDKA 7-9 am.
21.530	GSJ	DAVENTRY, ENG. , 13.93 m., Addr. (See 26.100 mc.) 5.45-8.55 am., 9.15 am.-12n.
21.520	W2XE	NEW YORK CITY , 13.94 m., Addr. Col. Broad. Syst., 485 Madison Ave. Relays WABC 6.30-9 am.
21.470	GSH	DAVENTRY, ENG. , 13.97 m. (See 26.100 mc.) 5.45-8.55 am., 9.15 am.-12 n.

↑ S.W. BROADCAST BAND ↑

21.420	WKK	LAWRENCEVILLE, N. J. , 14.01 m., Addr. Amer. Tel. & Tel. Co. Calls S. Amer. 7 am.-7 pm.
21.080	PSA	RIO DE JANEIRO, BRAZ. , 14.23 m., Calls WKK daytime.
21.060	WKA	LAWRENCEVILLE, N. J. , 14.25 m., Addr. (See 21.420 mc.) Calls England morning and afternoon.
21.020	LSN6	BUENOS AIRES, ARG. , 14.27 m., Addr. Cia. Internacional de Radio. Works N. Y. C. 7 am.-7 pm.
20.860	EHY-EDM	MADRID, SPAIN , 14.38 m., Addr. Cia. Tel. Nacional de Espana. Works S. Amer. mornings.
20.700	LSY	BUENOS AIRES, ARG. , 14.49 m., Addr. Transradio Internatl. Tests irregularly Brazil mornings.
20.380	GAA	RUGBY, ENG. , 14.72 m., Calls Arg., Brazil mornings.
20.040	OPL	LEOPOLDVILLE, BELGIAN CONGO , 14.97 m. Works ORG mornings.
20.020	DHO	NAUEN, GERMANY , 14.99 m., Addr. Reichspostzenstralamt. Works S. Am. mornings.
19.900	LSG	BUENOS AIRES, ARG. , 15.08 m., Addr. (See 20.700 mc.) Tests irregularly.
19.820	WKN	LAWRENCEVILLE, N. J. , 15.14 m., Addr. A. T. & T. Co. Calls England daytime.
19.680	CEC	SANTIAGO, CHILE , 15.24 m., Addr. Cia. Internacional de Radio. Calls Col. and Arg. daytime.
19.650	LSN5	BUENOS AIRES, ARG. , 15.27 m., Addr. (See 21.020 mc.) Calls Europe daytime

Mc.	Call	
19.620	VQG4	NAIROBI, KENYA , 15.28 m., Addr. Cable and Wireless, Ltd. Calls London 7.30-8 am.
19.600	LSF	BUENOS AIRES, ARG. , 15.31 m., Addr. (See 20.700 mc.) Tests irregularly.
19.480	GAD	RUGBY, ENG. , 15.4 m., Calls VQG4 7.30-8 am.
19.355	FTM	ST. ASSISE, FRANCE , 15.5 m., Calls S. America mornings.
19.345	PMA	BANDOENG, JAVA , 15.51 m., Works Holland 5.30-11 am.
19.260	PPU	RIO DE JANEIRO, BRAZ. , 15.58 m., Addr. Cia. Radiotel. Brasileira. Works France mornings.
19.220	WKF	LAWRENCEVILLE, N. J. , 15.6 m., Addr. A. T. & T. Co. Calls England daytime.
19.200	ORG	RUYSSSELEDE, BELGIUM , 15.62 m., Calls OPL mornings.
19.160	GAP	RUGBY, ENG. , 15.66 m., Calls Australia 1-8 am.
19.020	HS8PJ	BANGKOK, SIAM , 15.77 m., Mondays 8-10 am.
18.970	GAQ	RUGBY, ENG. , 15.81 m., Calls S. Africa mornings.
18.890	ZSS	KLIPHEUVEL, S. AFRICA , 15.88 m., Addr. Overseas Comm. of S. Africa, Ltd. Calls GAQ 9-10 am.
18.830	PLE	BANDOENG, JAVA , 15.93 m., Calls Holland early am.
18.680	OCI	LIMA, PERU , 16.06 m., Tests with Bogota, Col.
18.620	GAU	RUGBY, ENG. , 16.11 m., Calls N. Y. daytime.
18.480	HBH	GENEVA, SWITZERLAND , 16.23 m., Addr. Radio Nations. Tests irregularly.
18.345	FZS	SAIGON, INDO-CHINA , 16.35 m., Works Paris early morning.
18.340	WLA	LAWRENCEVILLE, N. J. , 16.36 m., Addr. A. T. & T. Co. Calls England daytime.
18.310	GAS	RUGBY, ENG. , 16.38 m., Calls N. Y. daytime.
18.299	YVR	MARACAY, VENEZ. , 16.39 m., Works Germany mornings.
18.250	FTO	ST. ASSISE, FRANCE , 16.43 m., Works S. America daytime.
18.200	GAW	RUGBY, ENG. , 16.48 m., Works N. Y. C. daytime.
18.135	PMC	BANDOENG, JAVA , 16.54 m., Works Holland mornings.
18.115	LSY3	BUENOS AIRES, ARG. , 16.56 m., Addr. (See 20.700 mc.) Tests irregularly.
18.040	GAB	RUGBY, ENG. , 16.83 m., Works Canada morning and afternoon.
17.810	PCV	KOOTWIJK, HOLLAND , 16.84 m., Works Java 9-8 am.

↓ S.W. BROADCAST BAND ↓

17.790	GSG	DAVENTRY, ENG. , 16.86 m., Addr. B.B. C., London. 11.30 pm.-1.45 am., 5.45-8.55 am., 9 am.-12 n., 12.20-3.45, 4-6, 6.20-8.30 pm.
17.785	JZL	TOKIO, JAPAN , 16.87 m., Tests irregularly.
17.780	W3XAL	BOUND BROOK, N. J. , 16.87 m., Addr. Natl. Broad. Co. 6.30 am.-6.30 pm.
17.770	PHI	HUIZEN, HOLLAND , 16.88 m., Addr. (See PHI, 11.730 mc.) Daily except Wednesday, 8-9.30 am.; Sun. 7-10 am.
17.760	DJE	BERLIN, GERMANY , 16.89 m., Addr. Broadcasting House. 12.05-5.15 am.; 5.55-11 am. Sun. 11.10 am.-12.25 pm.
17.760	W2XE	NEW YORK, N. Y. , 16.89 m., Addr. Col. Broad. System, 485 Madison Ave. 11 am.-12 n.

Mc.	Call	
17.755	ZBW5	HONGKONG, CHINA , 16.9 m., Addr. P. O. Box 200. 4-10 am. irregular.

↑ S.W. BROADCAST BAND ↑

17.741	HSP	BANGKOK, SIAM , 16.91 m., Works Germany 4-7 am.
17.650	XGM	SHANGHAI, CHINA , 17 m., Works London 7-9 am.
17.620	DFB	NAUEN, GERMANY , 17.12 m., Works S. America, near 9.15 am.
17.480	VWY2	KIRKEE, INDIA , 17.16 m., Works London 7.30-8.15 am.
17.120	WOO	OCEAN GATE, N. J. , 17.52 m., Addr. A. T. & T. Co. Works ships irregularly.
17.080	GBC	RUGBY, ENG. , 17.56 m., Works ships irregularly.
16.835	ITK	MOGADISCIO, ITAL SOMALILAND , 18.32 m., Calls IAC around 9.30 am.
16.270	WLK	LAWRENCEVILLE, N. J. , 18.44 m., Addr. A. T. & T. Co. Works S. Amer. daytime.
16.270	WOG	OCEAN GATE, N. J. , 18.44 m., Addr. A. T. & T. Co. Works England Late afternoon.
16.240	KTO	MANILA, P. I. , 18.47 m., Addr. RCA Comm. Works Japan and U. S. 5-9 pm. irregularly.
16.233	FZR3	SAIGON, INDO-CHINA , 18.48 m., Calls Paris early morning.
16.030	KKP	KAHUKU, HAWAII , 18.71 m., Addr. RCA Comm. Works Dixon 3-10 pm.
15.880	FTK	ST. ASSISE, FRANCE , 18.9 m., Works Saigon 8-11 am.
15.865	CEC	SANTIAGO, CHILE , 18.91 m., Calls Peru daytime irregular.
15.810	LSL	BUENOS AIRES, ARG. , 18.98 m., Addr. (See 21.020 mc.) Works London mornings and Paris afternoons.
15.660	JVE	NAZAKI, JAPAN , 19.16 m., Works Java 3-5 am.
15.620	JVF	NAZAKI, JAPAN , 19.2 m., Works Cal. near 5 am. and 8 pm.
15.450	IUG	ADDIS ABABA, ETHIOPIA , 19.41 m., Works Rome 9.15-10.30 am.
15.440	XEBM	MAZATLAN, SIN., MEX. , 19.43 m., Addr. Flores 103 Alto. "El Pregonero del Pacifico." Irregularly 7 am.-10 pm.
15.415	KWO	DIXON, CAL. , 19.46 m., Addr. A. T. & T. Co. Works Hawaii 2-7 pm.
15.370	HAS3	BUDAPEST, HUNGARY , 19.52 m., Addr. Radiolabor, Gyali Ut 22. Sun 9-10 am.
15.360	DZG	ZEESEN, GERMANY , 19.53 m., Addr. Reichspostzenstralamt. Tests irregularly.
15.355	KWU	DIXON, CALIF. , 19.53 m., Addr. A. T. & T. Co. Phones Pacific Isles and Japan.

↓ S.W. BROADCAST BAND ↓

15.340	DJR	BERLIN, GERMANY , 19.56 m., Addr. Broadcast'g House, 8-9 am., 4.50-10.45 pm.
15.330	W2XAD	SCHENECTADY, N. Y. , 19.56 m., Addr. General Electric Co. Relays WGY 10 am. to 8 pm.
15.310	GSP	DAVENTRY, ENG. , 19.6 m., Addr. (See 26.100 mc.) 6.20-8.30 pm.
15.290	LRU	BUENOS AIRES, ARG. , 19.62 m., Addr. El Mundo. Irregular
15.280	HIXX	CIUDAD TRUJILLO, D. R. , 19.63 m., Relays HIX Sun. 7.40-10.40 am. Week-days 12.10-1.10 pm.
15.280	DJQ	BERLIN, GERMANY , 19.63 m., Addr. Broadcasting House. 12.05-5.15, 6-8, 8.15-11 am., 4.50-10.45 pm.
15.270	W2XE	NEW YORK CITY , 19.65 m., Addr. (See 21.520 mc.) 2-5 pm.

(Continued on page 181)

(All Schedules Eastern Standard Time)

SHORT WAVES and LONG WAVES

Our Readers Forum

Built 25 of "Our" Sets—All Worked OK!

Editor, SHORT WAVE & TELEVISION:



I've been reading *Short Wave & Television* magazine for over three years. I've read all kinds of radio magazines; none of them had any "dope" which you could make use of, so I switched to *Short Wave & Television*. What a difference in radio magazines! There I found the real dope, just

what I was looking for, not a lot of advertisements and deep technical dope, that the beginner don't know a thing about. I started to build some of your sets, and I've built about twenty-five of them—from the small ones to the large babies. I found the diagrams and instructions easy to understand, and never had any trouble with them. They always worked 100% O.K.; just as you stated!

Your Kinks are excellent, they make my work easier and quicker; here's for more and better "Kinks."

I've heard over 1,000 "Hams" and S-W "broadcasts" from about 45 countries; all on the sets I built from your magazine. Most of my DXing is done on the 20 meter band. The information you give on 5-meters is excellent, and I hope you keep up the good work.

I am also a member of the *Short Wave League*, and very happy to be one! Through your magazine I have made friends with many "Hams" and SWLs all over the world. All I can say about short waves is—if you've read *Short Wave & Television* magazine, then you've read all the radio magazines!

If there is any SWL "Ham" that would like to "swap" photos, cards, or letters, I'd be only too glad to hear from them, especially from Europe, Asia, and South America. I'll answer all mail that I receive.

Wishing the "gang" and the Editors of *Short Wave & Television* 73 (best regards).

DANIEL SUSKO,
77 Crawford & East St.,
Cannonsburg, Pa.

Good News from Honolulu

Editor, SHORT WAVE & TELEVISION:



I received my "globe" in good condition and think it very attractive and beautiful.

Like many others, I have been reading *Short Wave & Television* for quite a number of years. Quite a few of the very first issues are filed with the latest issues.

For the beginner's as well as advanced students I recommend *Short Wave & Television*. In every issue there are always several useful Kinks and good simple-to-build receivers of the regenerative or other type, which any beginner can easily construct. For the advanced student there is invariably a good superheterodyne receiver.

A few suggestions I recommend are, more of the simple type of superhet for the beginner, and for the advanced reader, such
(Continued on page 190)

Official Report Station ZL-156, New Zealand

Editor, SHORT WAVE & TELEVISION:



I was appointed an ORS of the NZART on 26th November last. Since then I have reported to 772 amateur transmitting stations. Have sent out 953 reports and received 438 qsls. By the time this letter reaches you, I expect to have sent out well over 1000 reports.

The reports have gone to the following locations: Aleutian Islands, Argentina, Austria, Belgium, Bolivia, Borneo, Brazil, China, Chile, Colombia, Costa Rica, Ecuador, England, France, Dominican Republic, Haiti, Hawaii, India, Japan, Mexico, Panama, Peru, Philippine Islands, Cuba, Java, South Africa, Australia, most of the States in the U.S.A. and all parts of my own country.

The work has been full of interest and has offered many opportunities for useful service.

I have recently instituted a *Monthly Report Service* that aims at advising overseas "hams" who come into New Zealand with something like regularity, how their signals are reaching this field, etc.

I do not know whether you can find space for a suggestion that I think deserves attention. Considerable expense and labor is devoted to acquiring and maintaining first-class "rigs" and these "rigs" are made to put out some very fine signals. But time and time again in the course of my service as an ORS I find the best of dx transmissions very heavily discounted by very careless and slovenly speech. There is nothing I loathe more than speech affectation, especially over the "mike," but "hams" should take a tumble to the fact that to get real dx consistently, it is just plain common-sense transmitting technique to make the best possible use of the vocal organ we possess and to speak as clearly and distinctly as possible. In other words, give your "rig" a reasonable chance to do its stuff!

Greetings and 73 to "hams" everywhere—from "God's Own Country"—New Zealand.

HAROLD W. (TIDDY) TIDMAN,
Bayswater,
Auckland, New Zealand.



Famous Short Wave "Listening Post" of Harold W. (Tiddy) Tidman, Auckland, New Zealand.

A "Shout" from Canada

Editor, SHORT WAVE & TELEVISION:

I have been a constant reader of *Short Wave & Television* for quite a few years. My letterhead speaks for itself and you can grasp that I am connected with aeronautics. Short waves and television go hand-in-hand and there is likewise a connection between aeronautics and short waves. Aeronautics would be greatly hampered without short wave radio.

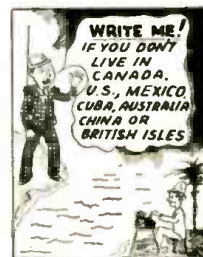

I have found *Short Wave & Television* to be a most satisfactory radio publication. It is written so that every class of experimenter, from the novice to the veteran, can understand it. Other radio publications cater mostly to the service-man, the transmitting "Ham," or aircraft radio, but *Short Wave & Television* caters to all classes in a most pleasing manner.

I have only one minor objection. I would like to see more circuits bearing the "tested and approved, certified circuit" seal. It affords greater prestige to the circuit.

I am sure that your (*our*) magazine is circulated in many countries and I would ask a favor of you. I would like to correspond with persons living in countries other than the following: Canada, U.S.A., Mexico, Cuba, Australia, China and the British Isles. My correspondence already covers the aforementioned countries. Correspondents should be 18 years of age, or over, and masculine only.

Hoping to see more certified circuits,
Sincerely yours,

COL. ROBT. M. SOUTAR, F.A.C., D.S.M.,
58 Delaware Ave.

Hamilton, Ont., Canada.
District Commander, "Flying Aces Club."

Heard 275 "Ham" Stations

Editor, SHORT WAVE & TELEVISION:

I wish to express my congratulations for such a fine magazine. It would be very nice if a person could receive it daily, Hi!

I have built the 2-tube Doerle, which was my first receiver. I heard many "foreign" stations and got excellent results. I changed the last 30 for a 33 and had to watch out for my ears. I heard three African "Hams" and two Australians, besides hundreds of North and South Americans on this set-up. At present, I have this kind of a set: A 34 for an untuned R.F. stage, a 37 for an electron-coupled detector, and two 30's in the audio stage. It works F. B. and I've heard plenty DX on this set, with but 3 or 4 days of listening. I call it the "Petrodyne." I have to depend upon battery sets, because there is no electric supply line less than 30 miles away.

Going back to the Doerle—2 30's and then one 30 and one 33, I heard over 275 "Hams" on the phone band on 20 meters, including all districts in Canada and U. S. A. I also heard several Cubans, Mexicans, S. A.'s, etc. Of course, if it wasn't for *Short Wave & Television*, I wouldn't have heard these stations.

At present, I am learning the code and hope to learn it soon, because I am very anxious to get on one of the fine "Ham" bands, and hook Shanghai or Java, Hi!

Well, I guess I'd never give enough praise for such an "F.B." magazine as "SW&T," so I'll sign off by saying 73, and best of luck after a most enjoyable QSO,
(Continued on page 190)

Mc.	Call	Station	Mc.	Call	Station	Mc.	Call	Station
15.260	GS1	DAVENTRY, ENG., 19.66 m., Addr. (See 26.100 mc.) 12.20-3.45, 9-11 pm.	15.500	LSM2	BUENOS AIRES, ARG., 20.69 m., Addr. (See 21.020 mc.) Works RIO and Europe daytime.	12.080	PDV	KOOTWIJK, HOLLAND, 24.88 m. Tests irregularly.
15.252	RIM	TACHKENT, U.S.S.R., 19.67 m. Works RKI near 7 am.	14.485	TIR	CARTAGO, COSTA RICA, 20.71 m. Works Central America and U. S.A. daytime.	12.000	RNE	MOSCOW, U.S.S.R., 25 m. Daily 3-6 pm., Sat., Sun., Tues., Thurs., 10.15-10.45 pm., also Sun. 6-11 am., Mon 6-7 am. and 8.30-9 pm. Wed. 6-7 am., Thurs. 8.30-9 pm.
15.250	WIXAL	BOSTON, MASS., 19.67 m., Addr. University Club. Sundays 11 am-12.30 pm. Irregular other days.	14.485	YSL	SAN SALVADOR, SALVADOR, 20.71 m. Irregular.	11.991	FZS2	SAIGON, INDO-CHINA, 25.02 m. Phones Paris mornings.
15.245	TPA2	PARIS, FRANCE, 19.68 m., Addr. 98 bis. Blvd. Haussmann. "Radio Colonial." 5-10.05 am.	14.485	HPF	PANAMA CITY, PANAMA, 20.71 m. Works WNC daytime.	11.960	HI2X	CIUDAD TRUJILLO, D. R., 25.08 m., Addr. La Voz de Hispaniola. Relays HIX Tue. and Fri. 8.10-10.10 pm.
15.230	HS8PJ	BANGKOK, SIAM, 19.32 m. Irregularly Mon. 8-10 am.	14.485	TGF	GUATEMALA CITY, GUATEMALA, 20.71 m. Works WNC daytime.	11.955	IUC	ADDIS ABABA, ETHIOPIA, 25.09 m. Works IAC around 12 midnight.
15.230	OLR5A	PRAGUE, CZECHOSLOVAKIA. Mon. and Thurs. 8-10.15 pm.	14.485	YNA	NICARAGUA, MANAGUA, 20.71 m. Works WNC daytime.	11.950	KKQ	BOLINAS, CALIF., 25.1 m. Tests irregularly evenings.
15.220	PCJ	HUIZEN, HOLLAND, 19.71 m., Addr. N. V. Philips' Radio, Hilversum. Tues. 4.30-6 am., Wed. 8-11 am.	14.485	HRL5	NACAOME, HONDURAS, 20.71 m. Works WNC daytime.	11.940	FTA	STE. ASSISE, FRANCE, 25.13 m. Works Morocco mornings and Argentina late afternoon.
15.210	W8XK	PITTSBURGH, PA., 19.72 m., Addr. (See 21.540 mc.) 9 am.-7 pm.	14.470	WMF	TEGUCIGALPA, HONDURAS, 20.71 m. Works WNC daytime.			
15.200	DJB	BERLIN, GERMANY, 19.74 m., Addr. (See 15.280 mc.) 12.05-5.15 am., 5.55-11 am., 4.50-11 pm. Also Sun. 11.10 am. to 12.25 pm.	14.460	DZH	LAWRENCEVILLE, N. J., 20.73 m., Addr. A. T. & T. Co. Works England daytime.			
15.190	ZBWA	HONGKONG, CHINA, 19.75 m., Addr. P. O. Box 200. 11.30 pm. to 1.15 am., 4-10 am., Sat. 9.15 pm.-1 am. Sun. 3-9.30 am.	14.440	GBW	ZEESEN, GERMANY, 20.75 m., Addr. (See 15.360 mc.) Irregular.	11.900	XEWI	MEXICO CITY, MEXICO, 25.21 m. Monday, Wed. and Fri. 3-4 pm., 9 pm.-12 m. Tues. to Thurs. 7.30 pm.-12 m. Sat. 9 pm. to 12 m. Sunday 12.30-2 pm.
15.180	GSO	DAVENTRY, ENG., 19.76 m., Addr. (See 26.100 mc.) 11.30 pm.-1.45 am., 5.45-8.55 am., 4-6, 6.20-8.30 pm.	14.200	EA9A	RUGBY, ENG., 20.78 m. Works U. S. A. afternoons.	11.895	HP5I	AGUADULCE, PANAMA, 25.22 m., Addr. La Vos del Interior. 7.30-9.30 pm.
15.180	RW98	MOSCOW, U.S.S.R., 19.76 m., Sun 2-3 pm.	13.990	GBA	TETUAN, SPANISH MOROCCO, 21.13 m. Daily except Sun. 2.15-5, 7 and 9 pm.	11.880	TPA3	PARIS, FRANCE, 25.23 m., Addr. (See 15.245 mc.) 4-5 am., 10.15 am.-5 pm.
15.160	JZK	TOKIO, JAPAN, 19.79 m., 2.30-3.30 pm., 4-5 pm., 12 m.-1 am.	13.820	SUZ	RUGBY, ENG., 21.44 m., Works Buenos Aires late afternoon.	11.870	W8XK	PITTSBURGH, PA., 25.26 m., Addr. (See 21.540 mc.) 7-10.30 pm.
15.150	YDC	BANDOENG, JAVA, 19.8 m., Addr. N. I. R. O. M. 6-7.30 pm. 10.30 pm.-2 am., Sat. 7.30 pm.-2 am., 5.30-10.30 am.	13.690	KKZ	ABOU ZABAL, EGYPT, 21.71 m. Works with Europe 11 am. to 2 pm.	11.860	YDB	SOERABAJA, JAVA, 25.29 m., Addr. N. I. R. O. M. Sat. 7.30 pm. to 2.30 am. daily 10.30 pm. to 2 am.
15.140	GSF	DAVENTRY, ENG., 19.82 m., Addr. (See 26.100 mc.) 9.15 am.-12 n., 4-6.9-11 pm.	13.635	SPW	BOLINAS, CALIF., 21.91 m., Addr. RCA Communications. Irregular.	11.860	GSE	DAVENTRY, ENG., 25.29 m., Addr. (See 26.100 mc.) Irregular.
15.120	HVJ	VATICAN CITY, 19.83 m., 10.30-10.45 am., except Sun., Sat. 10-15 am.	13.585	GBB	WARSAW, POLAND, 22 m., Mon., Wed. Fri., 12.30-1.30 pm.	11.855	DJP	BERLIN, GERMANY, 25.31 m., Addr. (See 15.280 mc.) Irregular 11.35 am. to 4 pm.
15.110	DJL	BERLIN, GERMANY, 19.85 m., Addr. (See 15.280 mc.) 12 m.-2, 8-9 am., 11.35 am. to 4.30 pm. Sun. also 6-8 am.	13.415	GCJ	RUGBY, ENG., 22.08 m. Works Egypt and Canada afternoon.	11.840	CSW	LISBON, PORT., 25.35 m., Nat'l Broad. Stat. 11.30 am.-1.30 pm.
			13.390	WMA	RUGBY, ENG., 22.36 m. Works Japan and China early morning.	11.840	OLR4A	PRAGUE, CZECHOSLOVAKIA, 25.35 m. Addr. Czech Shortwave Sta., Praha X11, Pochova 16. Daily 8.55 am. to 12 n. 2.25-4.30 pm. Sun. 2-7.30 am. Thurs. and Sat. 5-7.30 am. Mon. and Thurs., 7.55-10.15 pm.
			13.380	IDU	SAN SALVADOR, SALVADOR, 22.37 m. Works WNC daytime.	11.830	W9XAA	CHICAGO, ILL., 25.36 m., Addr. Chicago Federation of Labor. Irregular.
			13.345	YVQ	LAWRENCEVILLE, N. J., 22.4 m., Addr. A. T. & T. Co. Works England morning and afternoon.	11.830	W2XE	NEW YORK CITY, 25.36 m., Addr. Col. Broad. System, 485 Madison Av., N. Y. C., relays WABC 6-11 pm.
			13.285	CGA3	ASMARA, ERITREA, AFRICA, 22.42 m. Works Rome daytime.	11.820	XEBR	HERMOSILLA, SON., MEX., 25.38 m., Addr. Box 68. Relays XEBH. 2-4 pm., 9 pm.-12 m.
			13.255	IRJ	MARACAY, VENEZUELA, 22.48 m. Works WNC daytime.	11.820	GSN	DAVENTRY, ENG., 25.38 m., Addr. (See 26.100 mc.) Irregular.
			13.330	IRJ	ORUMMONOVILLE, QUE., CAN., 22.58 m. Works London and ships afternoons.	11.810	ZRO	ROME, ITALY, 25.4 m., Addr. E.I.R.R., Via Montello 5. Daily 6.43-10.30 am, 11.30 am.-5.30 pm., 6-7.45 pm. Sun. 6.43-9 am., 11.30 am.-5.30 pm.
			13.075	VPD	ROME, ITALY, 22.69 m. Works Tokio 5-9 am. irregularly.	11.800	OER2	VIENNA, AUSTRIA, 25.42 m. Daily 10 am.-5 pm. Sat. until 5.30 pm.
			12.940	WOO	SUVA, FIJI ISLANDS, 22.94 m. Irregularly.	11.795	DJO	BERLIN, GERMANY, 25.43 m., Addr. (See 15.280 mc.) Irregular.
			12.925	CNR	OCEAN GATE, N. J., 23.36 m., Addr. A. T. & T. Co. Works with ships irregularly.	11.795	OAX5B	ICA, PERU, 25.43 m., Addr. Radio Universal. 11 am.-12 n., 4-11.15 pm.
			12.800	IAC	RABAT, MOROCCO, 23.39 m., Addr. Director General Tele. & Teleg. Stations. Works with Paris irregularly.	11.790	COGF	MATANZAS, CUBA, 25.45 m., Addr. P. O. Box 51. Testing relays CMGF.
			12.780	GBC	PISA, ITALY, 23.45 m. Works Italian ships mornings.	11.790	WIXAL	BOSTON, MASS., 25.45 m., Addr. (See 15.250 mc.) Daily 3.30-5.45 pm. Irregular at other times.
			12.485	HIN	RUGBY, ENG., 23.47. Works ships irregularly.	11.770	DJO	BERLIN, GERMANY, 25.49 m., Addr. (See 15.280 mc.) 11.35 am.-4.30 pm., 4.50-11 pm.
			12.325	DAF	CIUDAD TRUJILLO, D. R., 24 m. "Broadcasting National." 12 n.-2 pm. 6-11 pm. approx.	11.760	OLR4B	PRAGUE, CZECHOSLOVAKIA, 25.51 m., Addr. (See 11.875 mc.) Irregular.
			12.300	CB615	NORDOEICH, GERMANY, 24.34 m. Works German ships daytime.	11.750	GSD	DAVENTRY, ENG., 25.53 m., Addr. B. B. C. London. 11.30 pm.-1.45 am., 12.20-3.45 pm., 6.20-8.30, 9-11 pm.
			12.290	GBU	SANTIAGO, CHILE, 24.39 m., Addr. Louis Desmaras, Casilla, 761. 11 am.-1 pm., 4-8 pm. Sun. 4-10 pm.	11.730		SAIGON, INDO CHINA, 25.57 m., Addr. Radio Philco. Irregular 5.30-9.30 am.
			12.250	TYB	RUGBY, ENG., 24.41 m. Works N. Y. C. evenings.	11.730	PHI	HUIZEN, HOLLAND, 25.57 m., Addr. N. Y. Philips' Radio. Irregular.
			12.235	TFJ	PARIS, FRANCE, 24.49 m. Irregular.			
			12.215	TYA	REYKJAVIK, ICELAND, 24.52 m. Works Europe mornings. Broadcasts Sun. 1.40-2.30 pm.			
			12.150	GBS	PARIS, FRANCE, 24.56 m. Works French ships in morning and afternoon.			
			12.130	DZE	RUGBY, ENG., 24.69 m. Works N. Y. C. evenings.			
			12.120	FVA	ZEESEN, GERMANY, 24.73 m., Addr. (See 15.360 mc.) Tests irregular.			
					ALGIERS, ALGERIA, 24.75 m. Calls Paris 12 m.-6.30 am.			

↓ S.W. BROADCAST BAND ↓

↑ S.W. BROADCAST BAND ↑

(All Schedules Eastern Standard Time)

(Continued on page 183)

WORLD-WIDE SHORT-WAVE REVIEW

-Edited By C. W. PALMER

Heaviside Layer—German Version

● AN idea of the effect which amateur transmitters working on the ultra-high bands has on the ionized layers surrounding the earth can be gained from the cartoon here which is reproduced from a recent issue of CQ (Berlin).

This cartoon, which is taken from a QSL card of a German amateur is supposed to represent the powerful "sig." getting out from this station.

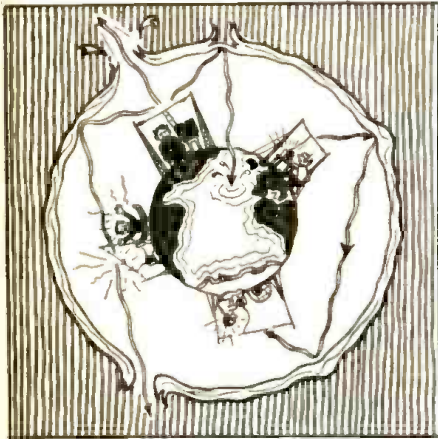

Cartoonist's conception of how the short waves bounce around between the earth and the Heaviside layer.

The disrupting action of the ultra-high frequency signals in breaking through the Heaviside layer which shows (at least an idea of) why these signals are not ordinarily reflected back to the earth to be picked up at great distances.

While the picture, being a cartoon, is not really true to actual conditions, it is instructive in presenting a pictorial version of the effect of radio waves on the layers which permit DX transmission.

Band-Spreading in Holland

● THE subject of band-spreading to simplify short-wave tuning has been discussed in many radio books and magazines. In a recent copy of *Radio-Centrum* (Hague) 3 interesting versions of band-spread circuits were shown.

These are reproduced here for those readers who may be interested.

The circuit at A is a method of using the regular tuning condenser for band-spreading. With the switch in the right-hand position, condenser C2 is short-circuited out of the tuning circuit and C3 is left out of the circuit. This permits normal tuning. With the switch in the left-hand position condenser C2 is connected in series with the tuning condenser C1 which effectively cuts down the capacity of the latter. This resulting small capacity permits spreading the tuning of stations on a small waveband. However, the reduction of capacity across the tuning coil shifts the tuning range and in order to cover the desired band, the trimmer capacity C3 is shunted across the two series condensers. This increases the over-all capacity to its original value, but permitting band-spreading if C1 is used for tuning.

The circuit B uses a tap on the tuning coil with a small variable condenser across the small portion of the coil. This condenser supplies the band-spread action.

The third version is perhaps the oldest method of band-spreading in use. This con-

\$25.00 FOR GOOD 1-TUBE SET

● THE editors know that our short-wave set-builders and experimenters must have developed some extra fine 1-tube circuits—possibly for receiving sets, short-wave converters, etc.

We are therefore offering \$25.00 for a good 1-tube set, either in the form of a short-wave receiver or a converter. Please note that there is little use in sending in an ordinary hook-up for a 3-element tube as most of the circuits possible with these tubes have been published.

What the editors want is a *new* circuit, designed around one of the latest type tubes having a multiplicity of grids. Refer to the March issue, page 675, where a very ingenious 1-tube S-W converter circuit is given. This will give you some idea of what we are after.

As a preliminary, you may send in a diagram and a description of the set and a good clear photo or two of it. A list of parts should accompany the description and the editors, who will act as the judges, and whose opinion will be final, reserve the privilege of requiring the set to be sent to them for inspection and test if they so desire. With the dual purpose tubes now available many ideas will suggest themselves. For example—Receivers with R. F. and Detector Stages; Detector and A.F. stage; Detector and Plate-Supply Rectifier; 1-tube Super-het; Reflex set, etc.

sists of connecting a small capacity across the main tuning condenser and thus varying its capacity by a small amount for the spreading.

In each of the three circuits shown, the circuit arrangement is for "cathode regeneration" or as it is sometimes called, *electron-coupling*.

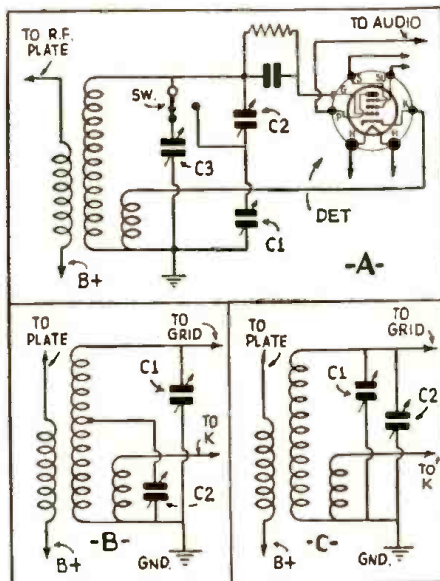

Three different methods of band-spreading.

An Improved Super-Regenerative Set

● IN some interesting experiments described in *Wireless-World* (London) recently by a well-known English writer, some facts about super-regenerative circuits were presented which will be of interest to short-wave "fans" who use this type of circuit.

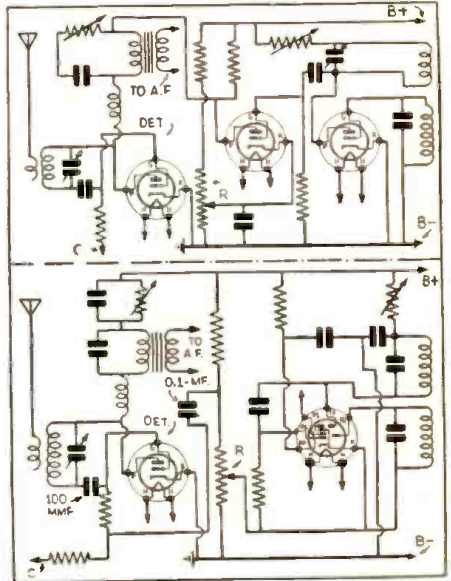

Experimental super-regenerative receiver hook-ups.

In the first place, the author points out that considerable work has been done in investigating the effects of varying the amplitude and frequency of the quenching oscillator—but that no work had apparently been done in the line of varying the waveform of this oscillator.

Some preliminary work discloses that a saw-tooth wave form should be very much better than the usual sinusoidal type in general use. The author tells of some experiments using the saw-tooth oscillator of an oscilloscope as the quenching oscillator, with a noticeable improvement in the reception of signals.

Next, a circuit was evolved using the conventional type of oscillator, but instead of feeding this directly to the detector tube, it was fed through a second tube which was "over-biased" so that the waveform of the oscillations could be varied by varying the bias. When the optimum wave form is obtained, the author claims an increase of about 3:1 when compared to the usual type of super-regenerator.

Two circuits are shown here. The first is the experimental one mentioned. This has two disadvantages in that an extra tube is required and also the quenching impulses are negative so that the oscillations of the detector are cut off by momentarily cutting off the plate current of the detector, which is the reverse of the usual method of applying a positive potential, which results in the flow of grid current, thus suppressing oscillations.

The second circuit eliminates both disadvantages since a combined triode-pentode (such as the 6F7) supplies the saw-tooth oscillations. The load resistance across which the oscillations are built up is shifted to the cathode circuit of the wave-form corrector, which reverses the polarity of quenching frequency applied to the detector.

The actual values required for the various condensers, resistors and coils must be worked out by the experimenter, since they were not given in the theoretical article in *Wireless World*.

Mc.	Call	Mc.	Call	Mc.	Call
11.720	CJRX	11.290	DZC	9.630	HJ2ABD
11.718	CR7RH	10.260	PMN	9.620	HJ1ABP
11.715	TPA4	10.250	LSK3	9.615	HP5J
11.710	SBG	10.230	CED	↓ S.W. BROADCAST BAND ↓	
↑ S.W. BROADCAST BAND ↑					
11.680	KIO	10.220	PSH	9.600	RAN
11.600	COGX	10.170	RIO	9.600	CB960
11.595	VRR4	10.140	OPM	9.595	HBL
11.560	VIZ3	10.080	RIO	9.590	PCJ
11.500	XAM	10.070	EDM-EHY	9.590	VK6ME
11.500	PMK	10.065	JZB-TDB	9.590	VK2ME
11.413	CJA4	10.055	ZFB	9.590	W3XAU
11.405	HBO	10.055	SUV	9.580	GSC
11.280	HIN	10.042	DZB	9.580	VK3LR
11.050	ZLT4	9.990	KAZ	9.575	HJ2ABC
11.040	CSW	9.950	GCU	9.570	W1XK
11.000	PLP	9.930	HKB	9.565	VUB
10.970	OCI	9.930	CSW	9.560	DJA
10.840	KWV	9.890	LSN	9.555	HJ1ABB
10.770	GBP	9.870	WON	9.550	OLR3A
10.740	JVM	9.860	EAQ	9.540	DJN
10.675	WNB	9.830	IRM	9.540	VPD2
10.670	WNB	9.800	LSI	9.535	JZI
10.670	WNB	9.790	GCW	9.530	W2XAF
10.670	WNB	9.760	VLJ-VLZ2	9.525	ZBW3
10.660	JVN	9.750	WOF	9.525	LKJ1
10.550	WOK	9.740	COCQ	9.520	HJ4ABH
10.535	JIB	9.710	GCA	9.510	VK3ME
10.520	VLK	9.675	DZA	9.510	GSB
10.430	YBG	9.670	TI4NRH	9.505	HJ1ABE
10.420	XGW	9.660	LRX	9.500	HJU
10.410	PDK	9.650	CT1AA	9.500	PRF5
10.410	KES	9.650	YDB	9.500	EAR-EAQ2
10.370	JVO	9.645	DGU	↑ S.W. BROADCAST BAND ↑	
10.370	EHZ	9.645	HH3W	(Continued on page 185)	
10.350	LSX	9.645	YNLF		
10.330	ORK	9.635	2RO		
10.300	LSL2				

(All Schedules Eastern Standard Time)

WHAT'S NEW

The short-wave apparatus here shown has been carefully selected for description by the editors after a rigid investigation of its merits.

In Short-Wave Apparatus

The New ACR-111 Receiver

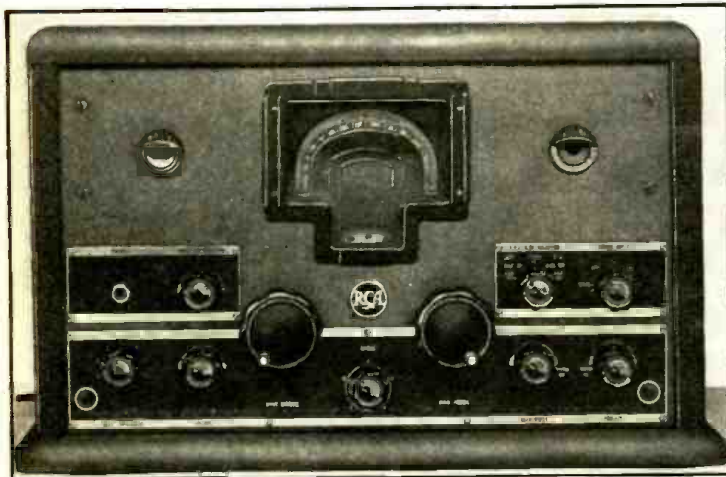

The range of each band covered in this receiver is:

TUNING RANGES

Band	Range, Megac.	Service
A	0.54 to 1.6	Standard Broadcast
B	1.6 to 4.0	Amateur, Police, Aviation
C	3 to 8	Amateur, Aviation, S-W Broadcast
D	6 to 16	Amateur S.W. Broadcast
E	12 to 30	Amateur S-W Broadcast

A Noise Limiter is incorporated in the circuit by means of the second diode of the second detector (RCA 6H6) tube. This device reduces peak noises, due to excessive signals or bursts of static.

The Selector Dial brings each scale separately into the dial opening by a turn of the Range Selector knob, and gives clear-vision tuning calibrations for the range in use only. In addition the vernier scale beneath provides for calibration spread, and the readings of both tuning and calibration spread scales may be entered in the "station log" for future reference. (Continued on page 194)

● THIS new, sixteen-tube, RCA Amateur Communication Receiver is built for rack and also for table mounting; it covers a frequency range of from 540 to 30,000 kc. It embodies the most up-to-date circuits and construction, including RCA metal tubes, electrical band-spread, beat-frequency oscillator, crystal filter, noise suppressor, noise limiter, sensitivity and automatic volume controls, standby switch, loudspeaker, and phone jack. The advanced degree of sensitivity and selectivity of the instrument, together with its frequency stability and reliability, open to the operator a field of reception covering all communications in the most important ranges.

The tubes used and their functions are as follows:

- 2 RCA-6K7 Radio Frequency Amplifiers
- 1 RCA-6J7 First Detector
- 1 RCA-6J7 Oscillator
- 2 RCA-6K7 Intermediate-Frequency Amplifiers
- 1 RCA-6H6 Second Detector and Noise Limiter
- 2 RCA-6C5 Audio-Voltage Amplifiers
- 2 RCA-6F6 Power Output Tubes
- 1 RCA-5Z3 Full Wave Rectifier
- 1 RCA-6J7 Beat-Frequency Oscillator
- 1 RCA-6R7 Automatic Volume Control
- 1 RCA Noise Suppressor
- 1 RCA Tuning Indicator

Above—top view of new ACR-111 receiver.

Right—Top view of latest RCA "Communications" receiver. It uses 16 tubes No. 633.

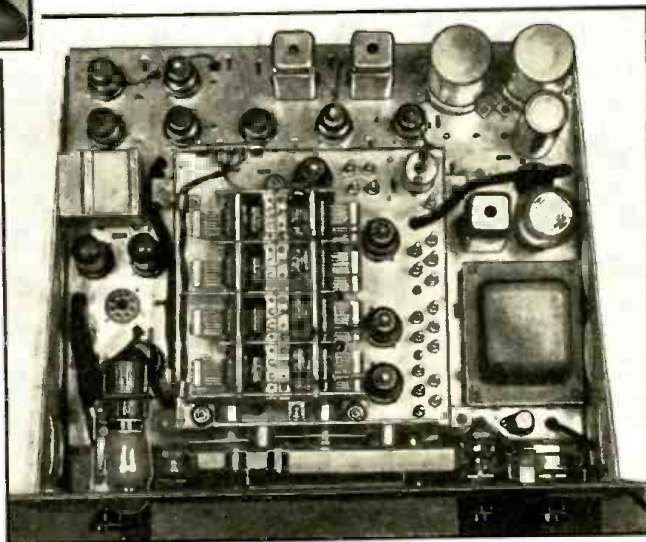

Compact Filter Capacitors

● A NEW line of capacitors has recently been announced by Cornell-Dubilier. They are contained in a 1½ inch by 4½

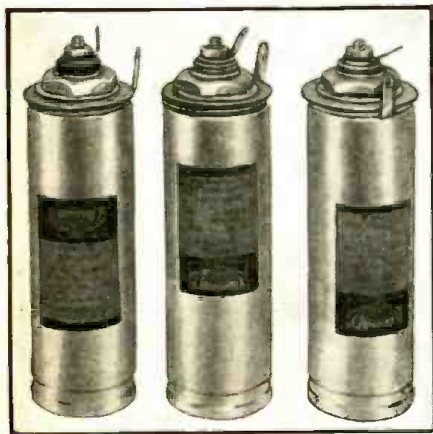

inch round metal case and three particular units are shown in the photograph. One has a capacity of 4 mf. with a D.C. working voltage of 600, the other a capacity of 2 mf. 1,000 V.C. working voltage, and still another is a 1 mf. 1,500 volt unit.

These are approximately the same size as the usual electrolytic condenser and are mounted in the same manner. They are furnished with insulating washers, permitting them to be mounted on metal frames or chassis.

The compactness of these units make them well suited to apparatus in which space is at a premium. (No. 631)

New Earphone Cap Improves Reception

● IN the picture we see two views of the new earphone cap. The upper right-hand drawing is a cut-away view showing half of the cap, while the lower right-hand drawing is a cross-section view. As can be readily seen in the drawing, this cap is composed of two halves in which are especially molded grooves or sound cham-

bers. These sound chambers provide a load on the dia- (Continued on page 194)



Cut-away views of the new high-quality earphone cap. No. 632

Names and addresses of manufacturers of apparatus furnished upon receipt of postcard request; mention No. of article.

Mc.	Call	Location, Time	Mc.	Call	Location, Time	Mc.	Call	Location, Time
9.480	XEFT	VERA CRUZ, MEXICO, 31.61 m. 11.30 am. to 4 pm., 7 pm. to 12 m.	7.975	HC2TC	QUITO, ECUADOR, 37.62 m. Thurs. and Sun. at 8 pm.	6.625	PRADO	RIOBAMBA, ECUADOR, 45.28 m. Thurs. 9-11.45 pm.
9.470	XEDQ	GUADALAJARO, GAL., MEXICO, 31.68 m. Irregular 7.30 pm. to 12.30 am.	7.901	LSL	HURLINGHAM, ARGENTINA, 37.97 m. Works Brazil at night.	6.558	HI4D	CIUDAD TRUJILLO, D. R., 45.74 m. Except Sun. 11.55 am.-1.40 pm.
9.460	ICK	TRIPOLI, N. AFRICA, 31.71 m. Works Rome, 5.30-7 am.	7.860	SUX	ABOU ZABAL, EGYPT, 38.17 m. Works with Europe, 4-6 pm.	6.550	XBC	VERA CRUZ, MEX., 45.8 m. 8.15-9 am.
9.450	TGWA	GUATEMALA CITY, GUATEMALA, 31.75 m., Addr. Ministre de Fomento. Daily 12 n. to 2 pm., 8 pm. to 12 m. Sat. 9 pm. to 5 am. (Sun.)	7.854	HC2JSB	GUAYAQUIL, ECUADOR, 38.2 m. Evenings.	6.550	TIRCC	SAN JOSE, COSTA RICA, 45.8 m., Addr. Radioemisora Catolica Costarricense. Sun. 11 am.-2 pm., 6-7, 8-9 pm. Daily 12 n.-2 pm., 6-7 pm., Thurs. 6-11 pm.
9.440	FZF6	FORT de FRANCE, MARTINIQUE, 31.78 m. 11.30 am., 12.30 pm., 6.15-7.15 pm., 8-9 pm.	7.799	HBP	GENEVA, SWITZERLAND, 38.47 m., Addr. Radio-Nations. Irregular.	6.545	YV6RB	BOLIVAR, VENEZUELA, 45.84 m., Addr. "Ecos de Orinoco." 6-10.30 pm.
9.440	HC2RA	GUAYAQUIL, ECUADOR, 31.78 m. Irregularly till 10.40 pm.	7.715	KEE	BOLINAS, CAL., 38.89 m. Relays NBC and CBS programs in evening irregularly.	6.530	YN1GG	MANAGUA, NICARAGUA, 45.94 m., Addr. "La Voz de los Lagos." 8-9 pm.
9.428	COCH	HAVANA, CUBA, 31.8 m., Addr. 2 B St., Vedado. 7 am.-1 am.	7.626	RIM	TACHKENT, U.S.S.R., 39.34 m. Works with Moscow in early morning.	6.520	YV4RB	VALENCIA, VENEZUELA, 46.01 m. 11 am.-2 pm., 5-10 pm.
9.415	PLV	BANDOENG, JAVA, 31.87 m. Works Holland around 9.45 am.	7.610	KWX	DIXON, CAL., 39.42 m. Works with Hawaii, Philippines, Java and Japan, nights.	6.500	HIL	CIUDAD TRUJILLO, D. R., 46.15 m., Addr. Apartado 623. 12.10-1.40 pm., 5.40-7.40 pm.
9.350	HS8PJ	BANGKOK, SIAM, 32.09 m. Thursday, 8-10 am.	7.550	TI8WS	PUNTA ARENAS, COSTA RICA, 39.74 m., Addr. "Ecos Del Pacifico", P. O. Box 75. 6 pm.-12 m.	6.500	TIOW	PUERTO LIMON, COSTA RICA, 46.15 m., Addr. Ondas del Caribe. Daily 12 n.-1.30 pm.
9.330	CGA4	DRUMMONDVILLE, CANADA, 32.15 m. Works England irregularly.	7.520	KKH	KAHUKU, HAWAII, 39.89 m. Works with Dixon and broadcasts irregularly nights.	6.477	HI4V	SAN FRANCISCO de MACORIS, D. R., 46.32 m. 11.40 am.-1.40 pm., 5.10-9.40 pm.
9.330	OAX4J	LIMA, PERU, 32.15 m., Addr. Box 1166, "Radio Universal." 7 pm.-12 m.	7.510	JVP	NAZAKI, JAPAN, 39.95 m. Irregular.	6.470	YNLAT	GRANADA, NICARAGUA, 46.36 m., Addr. Leonidas Tenoria, "La Voz del Mombacho." Irregular.
9.300	YNGU	MANAGUA, NICARAGUA, 32.26 m. 12 n.-2 pm., 6-7 pm.	7.500	RKI	MOSCOW, U.S.S.R., 40 m. Works with RIM early am.	6.450	HI8A	CIUDAD TRUJILLO, D. R., 46.51 m. 8.40-10.40 am., 2.40-4.10 pm. Sat. 9.40-10.40 pm. Sun. 2.40-4.40 pm.
9.280	GCB	RUGBY, ENGLAND, 32.33 m. Works Canada and Egypt evenings and afternoons.	7.390	ZLT2	WELLINGTON, N. Z., 40.6 m. Works with Sydney, 3-7 am.	6.420	HIIS	SANTIAGO, D. R., 46.73 m. 11.40 am.-1.40 pm., 5.40-7.40, 9.40-11.40 pm.
9.170	WNA	LAWRENCEVILLE, N. J., 32.72 m. Works England evenings.	7.380	XECR	MEXICO CITY, MEX., 40.65 m., Addr. Foreign Office. Sunday 6-7 pm.	6.410	TIPG	SAN JOSE, COSTA RICA, 46.8 m., Addr. Apartado 225, "La Voz de la Victor." 12 n.-2 pm., 6-11.30 pm.
9.150	YVR	MARACAY, VENEZUELA, 32.79 m. Works with Europe afternoons.	7.220	HKE	BOGOTA, COL., S. A., 41.55 m. Tues. and Sat. 8-9 pm. Mon. and Thurs. 6.30-7 pm.	6.400	YV5RH	CARACAS, VENEZUELA, 46.88 m. 7-11 pm.
9.125	HAT4	BUDAPEST, HUNGARY, 32.88 m., Addr. "Radiolabor," Gyali-ut, 22. Sun. and Wed. 7-8 pm., Sat. 6-7 pm.	7.200	YNAM	MANAGUA, NICARAGUA, 41.67 m. Daily at 9 pm.	6.380	YV5RF	CARACAS, VENEZUELA, 47.02 m., Addr. Box 983. 6-10.30 pm.
9.060	TFK	REYKJAVIK, ICELAND, 33.11 m. Works London afternoons.	7.100	FO8AA	PAPEETE, TAHITI, 42.25 m., Addr. Radio Club Papeete. Tues. and Fri. 11 pm.-12 m.	6.360	HRP1	SAN PEDRO SULA, HONDURAS, 47.19 m. 7.30-9.30 pm.
9.020	GCS	RUGBY, ENGLAND, 33.26 m. Works N. Y. C. evenings.	6.996	PZH	PARAMIRABO, DUTCH GUIANA, 42.88 m., Addr. P. O. Box 18. Daily 6.06-8.36 am., Sun. 9.36-11.36 am., Daily 5.36-8.36 pm.	6.360	YV1RH	MARACAIBO, VENEZUELA, 47.19 m., Addr. "Ondas Del Lago," Apartado de Correos 261. 6-7.30 am., 11 am.-2 pm., 5-11 pm.
9.010	KEJ	BOLINAS, CAL., 33.3 m. Relays NBC and CBS programs in evening irregularly.	6.976	HCETC	TACUBAYA, D. F., MEX., 43 m. 9.30 am.-1 pm., 7-8.30 pm.	6.350	HRY	TEGUCIGALPA, HONDURAS, 47.24 m. 6.30-8.30 pm.
8.957	VWY	KIRKEE, INDIA, 33.43 m. Works with England in morning.	6.905	GDS	QUITO, ECUADOR, 43 m., Addr. Teatro Bolivar. Thurs. till 9.30 pm.	6.340	HIIX	CIUDAD TRUJILLO, D. R., 49.32 m. Sun. 7.40-10.40 am., daily 12.10-1.10 pm., Tues. and Fri. 8.10-10.10 pm.
8.960	FVA	ALGIERS, ALGERIA, 33.48 m. Works Paris afternoons.	6.860	KEL	RUGBY, ENG., 43.45 m. Works N.Y.C. evenings irregularly.	6.316	HIZ	CIUDAD TRUJILLO, D. R., 47.5 m. Daily except Sat. and Sun. 11.10 am.-2.25 pm., 5.10-8.40 pm. Sat. 5.10-11.10 pm. Sun. 11.40 am.-1.40 pm.
8.950	HCJB	QUITO, ECUADOR, 33.5 m. 7-10 pm. except Monday.	6.850	XGOX	BOLINAS, CALIF., 43.70 m. Tests irregularly. 11 am.-12 n., 6-9 pm.	6.310	TG2	GUATEMALA CITY, GUAT., 47.55 m., Addr. Secretaria de Fomento. Relays TG1 11 pm.-1 am.
8.795	HKV	BOGOTA, COLOMBIA, 34.09 m. Mon. and Thurs. 7-7.30 pm.	6.800	HI7P	NANKING, CHINA, 43.8 m. Daily 6.40-8.40 am., Sun. 4.40-8.05 am.	6.300	YV4RG	MARACAY, VENEZUELA, 47.62 m. 8-10.30 pm.
8.775	PNI	MAKASSER, CELEBES, N. I., 34.19 m. Works Java around 4 am.	6.770	HI7P	CIUDAD TRUJILLO, DOM. REP., 44.12 m., Addr. Emisoria Diaria de Comercio. Daily exe. Sat. and Sun. 12.40-1.40, 6.40-8.40 pm. Sat. 12.40-1.40 pm. Sun. 10.40 am.-11.40 am.	6.282	COHB	SANCTI SPIRITUS, CUBA, 47.76 m., Addr. P. O. Box 85. 4-6, 9-11 pm.
8.765	DAF	NORDDEICH, GERMANY, 34.23 m. Works German ships irregularly.	6.775	WOA	SAN PEDRO DE MACORIS, DOM. REP., 44.26 m. 12.10-1.40 pm., 7.30-9 pm. Sun. 3-4 am., 4.15-6 pm., 4.40-7.40 pm.	6.280	HIG	CIUDAD TRUJILLO, D. R., 47.77 m. 7.10-8.40 am., 12.40-2.10, 8.10-9.40 pm.
8.760	GCQ	RUGBY, ENGLAND, 34.25 m. Works Africa afternoons.	6.750	JVT	LAWRENCEVILLE, N. J., 44.41 m., Addr. A. T. & T. Co. Works England evenings.	6.270	YV5RP	CARACAS, VENEZUELA, 47.79 m., Addr. "La Voz de la Philco." Irregular.
8.750	FZE8	DJIBOUTI, FR. SOMALILAND, AFRICA, 34.29 m. Works Paris around 2.30 am.	6.730	HI3C	NAZAKI, JAPAN, 44.44 m., Addr. Kokusai-Denwa Kaisha, Ltd., Tokio. Irregular.	6.243	HIN	CIUDAD TRUJILLO, D. R., 48 m., Addr. "La Voz del Partido Dominicano." 12 m.-2 pm., 7.30-9.30 pm., irregularly.
8.730	GCI	RUGBY, ENGLAND, 34.36 m. Works India 8 am.	6.720	PMH	LA ROMANA, DOM. REP., 44.58 m., Addr. "La Voz de la Feria." 12.30-2 pm., 5-6 pm.	6.235	HRD	LA CEIBA, HONDURAS, 48.12 m., Addr. "La Voz de Atlantida." 8-11 pm.; Sat. 8 pm.-1 am.; Sun. 4-6 pm.
8.720	VPD3	SUYA, FIJI ISLES, 34 m., Addr. (See 9.540 mc., VPD2). 5.30-7 am.	6.710	TIEP	BANDOENG, JAVA, 44.64 m. Relays NIROM programs. 5.30-9 am.	6.230	YV1RG	VALERA, VENEZUELA, 48.15 m. 6-9.30 pm.
8.680	GBC	RUGBY, ENGLAND, 34.56 m. Works ships irregularly.	6.672	YVQ	SAN JOSE, COSTA RICA, 44.71 m., Addr. Apartado 267, La Voz del Tropico. Daily 7-10 pm.	6.230	OAX4G	LIMA, PERU, 48.15 m., Addr. Apartado 1242. Daily 7-10.30 pm.
8.665	CO9JQ	CAMAGUEY, CUBA, 34.62 m., Addr. 4 General Gomez. 5.30-6.30, 8-9 pm., daily except Sat. and Sun. Also tests using call COJK, 9.45-11 pm.	6.670	HC2RL	MARACAY, VENEZUELA, 44.95 m. Sat. 8-9 pm.	6.210	YV5RI	CORO, VENEZUELA, 48.31 m., Addr. Roger Leyba, care A. Urbina y Cia. Irregular.
8.580	YNLG	MANAGUA, NICARAGUA, 34.92 m. 7.30-9.30 pm.	6.650	IAC	GUAYAQUIL, ECUADOR, S. A., 44.95 m., Addr. P. O. Box 759. Sun. 5.45-7.45 pm., Tues. 9.15-11.15 pm.	6.190	HI8Q	CIUDAD TRUJILLO, D. R., 48.47 m. 11.45 am.-1 pm., 4.45-6.45 pm.
8.560	WOO	OCEAN GATE, N. J., 35.05 m. Works ships irregularly.	6.630	HIT	PISA, ITALY, 45.11 m. Works ships irregularly.	6.185	HI1A	SANTIAGO, D. R., 48.5 m., Addr. P. O. Box 423. 11.40 am.-1.40 pm.; 7.40-9.40 pm.; Wed. 6-10.30 pm.
8.400	HC2CW	GUAYAQUIL, ECUADOR, 35.71 m. 11.30 am.-12.30 pm., 8-11 pm.			CIUDAD TRUJILLO, D. R., 45.25 m., Addr. "La Voz de la RCA Victor," Apartado 1105. Daily exe. Sun. 12.10-1.40 pm., 5.40-8.40 pm.; also Sat. 10.40 pm.-12.40 am.	6.171	XEXA	MEXICO CITY, MEX., 48.61 m., Addr. Dept. of Education. 7-11 pm.

(Continued on page 187)

(All Schedules Eastern Standard Time)

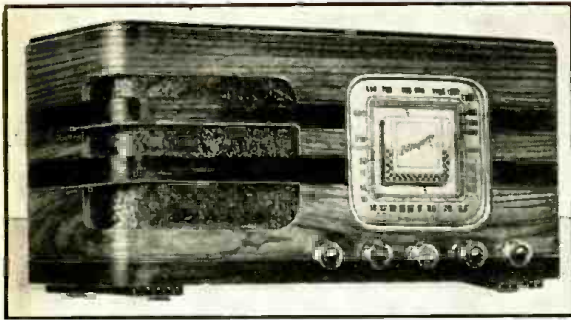

This "Universal" receiver works on 110 volts A.C. or 6 volt battery. Ideal for vacationists.

Universal Receiver for the Trailer, Boat or Home

By John de Leon

Range 16-58 and 193-550 meters; A.C. or Battery Operation.

aboard the trailer, or from the 110 volt A.C. service in the home. The model D-32 receiver consists of a 6 tube, 2 band receiver, incorporating a synchronous rubber-mounted vibrator for power-supply on 6 volts and a 25Z5, half-wave rectifier, voltage doubler, for power supply on 110 volts A.C.

The receiver is of single-unit construction, mounted in a home radio mantel cabinet of fine construction and appearance, and resembles in every way, the 1937 home radio receiver. It greatly differs however, in the fact that it may be used in the trailer, or aboard the boat, during the summer months, or even in the summer homes, isolated from power lines. A 6-volt storage battery, charged up from (Continued on page 197)

● THE trailer, though not a new idea, has become popular entirely through the advent of good roads and lower purchase costs of equipment. Needless to say, every possible point of luxury for the trailer has been taken into account. However, entertainment for the trailer tenants, up to the present has been supplied by an adapted automobile radio, purchased intentionally for use in the trailer during the few brief summer vacation months.

As the power supply to the trailer is in practically all instances taken from the car storage battery, it is generally 6 volts D.C. In a few instances, the deluxe and higher-priced trailers, or units designed for advertising purposes are equipped with gasoline-driven, motor-generator sets. These are constructed under the trailer chassis, and supply 110 volts A.C. when operated. This type of construction entails more than one drawback, as power is only available when the M-G set is in operation and aside from the fact that the motor creates considerable audible disturbance, it in addition creates radio frequency noise generation detrimental to good radio reception. As previously mentioned, trailer manufacturers and owners have equipped their "palaces on wheels" with 6-volt radio receivers constructed as automobile radios but adapted for use in the trailer.

1937 and LAFAYETTE have brought forth a new and absolutely fool-proof Universal radio receiver designed to operate from 6-volt battery source

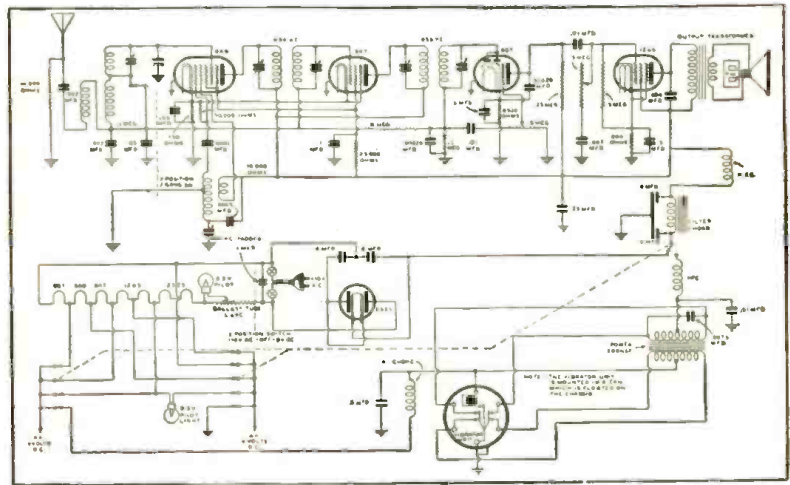

Novel hook-up of Lafayette "short" and "broadcast" wave receiver. No. 634

New Portable Works "Duplex" on 6 Vt. Mobile or A.C. Has Separate Transmitter and Receiver Circuits

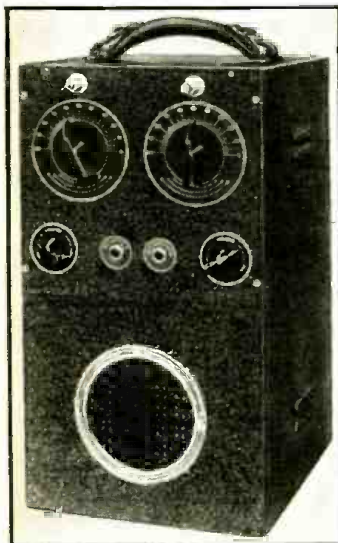

This Ultra Mobile Duplex portable works on A.C. or 6 volt D.C. No. 635

● INDICATIONS point to feverish 5-meter mobile activity this summer. One answer to this ideal form of amateur recreation is the ultra high frequency 6-volt mobile or A.C. Duplex.

This unit may be operated in a car, truck or trailer, directly from the storage battery, no other batteries being necessary. Simply by removing the built-in filtered genemotor and substituting for it the A.C. power-supply, A.C. operation may immediately be had. Absolutely no changes in wiring need be made, as both power-supplies are directly interchangeable. All that is necessary is to remove the cable from the power-supply socket.

Unlike other units intended for Duplex operation which use a common audio system, in the Ultra Mobile Duplex the receiver and transmitter are entirely separated and

independent of one another. This system is absolutely necessary for trouble-free, genuine duplex operation at optimum efficiency. It is obvious that its greater cost has prevented it from being more commonly used.

Separate antennae are used to obtain the peak of efficiency for both units, at the particular frequencies of reception and transmission.

The transmitter consists of a 6E6 oscillator, a 6J7 speech amplifier and a 6L6 modulator. A carrier output of 10 watts with 100 per cent modulation is obtained from this combination.

This is much more power than is usually required for the average 5-meter QSO. Surprising distances may be covered in average locations with great reliability.

A single-button carbon mike may be connected directly to the unit. No microphone battery is required, the "mike" current coming directly from the transmitter itself.

Sufficient output is derived from the 6L6 to provide complete modulation.

Three additional tubes are used in the receiver. The ideal ultra high frequency, super-sensitive 6J5G tube is the super-regenerative detector. The efficiency of this tube at extremely short wavelengths is comparable to that of the acorn types. A new type of super-regenerative (Continued on page 197)

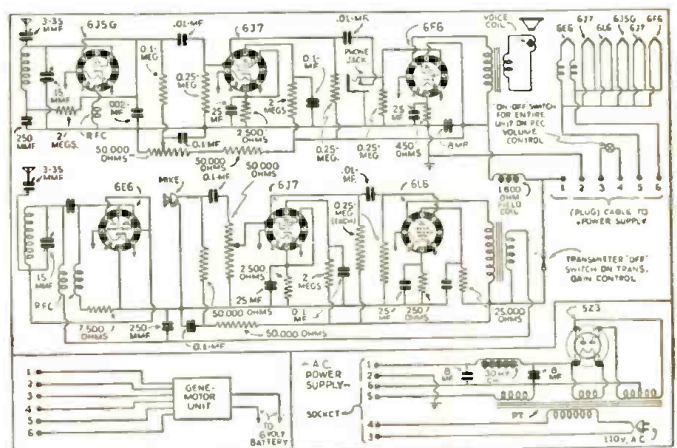

Interesting diagram of the "duplex" portable; it has "separate" transmitter and receiver circuits, preventing all "interlocking."

Names and addresses of manufacturers of apparatus furnished upon receipt of postcard request; mention No. of article.

↓ S.W. BROADCAST BAND ↓

Table with columns Mc. and Call. Entries include: 6.160 YVSRD CARACAS, VENEZUELA, 48.7 m. 11 am.-2 pm., 4-10.40 pm.; 6.160 VUZ COLOMBO, CEYLON, 48.7 m. Daily exe. Thurs. and Fri., 7-11.30 pm.; 6.150 CSL LISBON, PORTUGAL, 48.78 m. Irregular. 7-8.30 am., 2-7 pm.; 6.150 CJRO WINNIPEG, MAN., CANADA, 48.78 m., Addr. (See 11.720 mc.) 4-10 pm.; 6.147 ZEB BULAWAYO, RHODESIA, S. AFRICA, 48.8 m. Sun. 3.30-5 am.; Tues., Fri., 1.15-3.15 pm.; Mon. and Thurs. 11 am.-12 m.; 6.147 COKG SANTIAGO, CUBA, 48.8 m., Addr. Box 137. 9-10 am., 11.30 am.-1.30 pm., 3-4.30 pm., 10-11 pm., 12 m.-2 am.; 6.145 HJ4ABU PEREIRA, COL., 48.8 m. 9.30 am.-12 m., 6.30-10 pm.; 6.140 W8XK PITTSBURGH, PA., 48.86 m., Addr. Westinghouse Electric & Mfg. Co. Relays KDKA 9 pm.-12 m.; 6.137 CR7AA LAURENCO MARQUES, PORT. E. 48.87 m. 4-9, 10.30-11 am., 12 m.-3.30 pm., 11.15 pm.-1 am.; 6.135 HJ1ABB BARRANQUILLA, COL., 48.9 m., Addr. P. O. Box 715. 11.30 am.-1 pm., 4.30-10 pm.; 6.135 HI5N SANTIAGO, D. R., 48.9 m. 6.40-9.10 pm; 6.130 TGXA GUATEMALA CITY, GUAT., 48.94 m., Addr. Giornal Liberal Progressista. Irregularly.; 6.130 COCD HAVANA, CUBA, 48.94 m., Addr. Calle G y 25, Vedado. Relays CMCD 11 am.-12 m., 7-10 pm.; Sun. 12m.-4 pm.; 6.130 VE9HX HALIFAX, N. S., CAN., 48.94 m., Addr. P. O. Box 998. Mon.-Fri. 9 am.-1 pm., 5-11 pm. Fri.; 1-3 pm., Sat.; Sun. 9 am.-1 pm., 2-11 pm. Relays CHNS.; 6.130 ZGE KUALA LUMPUR, FED. MALAY ST., 48.94 m. Sun., Tue. and Fri. 6.40-8.40 am.; 6.130 LKL JELOY, NORWAY, 48.94 m. 11 am.-6 pm.; 6.125 CXA4 MONTEVIDEO, URUGUAY, 48.98 m., Addr. Radio Electrico de Montevideo., Mercedes 823. 10 am.-12 n. 2-8 pm.; 6.125 OAX1A CHICLAYO, PERU, 48.98 m., Addr. La Voz de Chivlayo, Casilla No. 9. 8-11 pm.; 6.122 OAX4P HUANCAYO, PERU, 49 m. La Voz del Centro del Peru. 8 pm. on.; 6.122 HP5A PANAMA CITY, PAN., 49 m. Addr. Box 58. 12 n-1 pm., 8-10 pm.; 6.122 HJ3ABX BOGOTA, COL., 49 m., Addr. La Voz de Col., Apartado 2663. 10.30 am.-2 pm., 5.30-11 pm.; Sun. 6-11 pm.; 6.120 W2XE NEW YORK CITY, 49.02 m., Addr. Col. B'cast. System, 485 Madison Ave. Irregular.; 6.120 XEUZ MEXICO CITY, MEX., 49.02 m., Addr. 5 de Mayo 21. Relays XEFO 1-3 am.; 6.115 OLR2C PRAGUE, CZECHOSLOVAKIA, 49.05 m. (See 11.875 mc.); 6.110 XEPW MEXICO CITY, MEX., 49.1 m., Addr. La Voz de Aguila Azteca desde Mex., Apartado 8403. Relays XEJW 11 pm.-1 am.; 6.110 VUC CALCUTTA, INDIA, 49.1 m. Daily 3-5.30 am., 9.30 am.-12 m.; Sun 7.30 am.-12 m.; 6.105 HJ4ABB MANIZALES, COL., 49.14 m., Addr. P. O. Box 175. Mon.-Fri 12.15-1 pm.; Tue. and Fri. 7.30-10 pm.; Sun 2.30-5 pm.; 6.100 W3XAL BOUND BROOK, N. J., 49.18 m., Addr. Natl. Broad. Co. 7-10 pm.; 6.100 W9XF CHICAGO, ILL., 49.18 m., Addr. N.B.C. 10.30 pm.-1 am.; 6.100 HJ4ABE MEDELLIN, COL., 49.18 m. 11 am.-12 m., 6-10.30 pm.; 6.097 ZTJ JOHANNESBURG, S. AFRICA, 49.2 m., Addr. African Broad. Co. Sun.-Fri. 11.45 pm.-12.30 am.; Mon.-Sat. 3.30-7 am., 9 am.-4 pm.; Sun. 8-10.15 am., 12.30-3 pm.

Table with columns Mc. and Call. Entries include: 6.095 JZH TOKIO, JAPAN, 49.22 m., Addr. (See 11.800 mc., JZJ.) Irregular.; 6.092 OAX4Z LIMA, PERU 49.25 m. Radio National 7-11 pm.; 6.090 HJ4ABC IBAQUE, COL., 49.26 m. 7 pm.-12 m.; 6.090 CRCX TORONTO, CAN., 49.26 m., Addr. Can. Broadcasting Corp. Daily 5.30-11.30 pm.; Sun. 5-11.30 pm.; 6.090 ZBW2 HONGKONG, CHINA, 49.26 m., Addr. P. O. Box 200. Irregular.; 6.085 HJ5ABD CALI, COLOMBIA, 49.3 m., Addr. La Voz de Valle. 12m.-1.30 pm., 5.10-9.40 pm.; 6.083 VQ7LO NAIROBI, KENYA, AFRICA, 49.31 m., Addr. Cable and Wireless, Ltd. Mon.-Fri. 5.45-6.15 am., 11.30 am.-2.30 pm.; also Tues. and Thurs. 8.30-9.30 am.; Sat. 11.30 am.-3.30 pm.; Sun. 11 am.-2 pm.; 6.080 ZHJ PENANG, FED. MALAY STATES, 49.34 m. 6.40-8.40 am., except Sun., also Sat. 11 pm.-1 am.; 6.080 CP5 LAPAZ, BOLIVA, 49.34 m. 7-10.30 pm.; 6.080 HP5F COLON, PAN., 49.34 m., Addr. Carlton Hotel. 11.45am.-1.15 pm., 7.45-10 pm.; 6.080 W9XAA CHICAGO, ILL., 49.34 m., Addr. Chicago Fed. of Labor. Relays WCFL irregular; 6.079 DJM BERLIN, GERMANY, 49.34 m., Addr. Broadcasting House. Irregular.; 6.070 HJ3ABF BOGOTA, COL., 49.42 m. 7-11.15 pm.; 6.070 CFRX TORONTO, CAN., 49.42 m. Relays CFRB irregularly 7 am.-12 m.; 6.070 YV1RE MARACAIBO, VEN., 49.42 m. 6-11pm.; 6.070 VE9CS VANCOUVER, B. C., CAN., 49.42 m. Sun. 1.45-9 pm., 10.30 pm.-1am.; Tues. 6-7.30 pm., 11.30 pm.-1.30 am. Daily 6-7.30 pm.; 6.065 HJ4ABL MANIZALES, COL., 49.46 m. Daily 11 am.-12 m., 5.30-7.30 pm.; Sat. 5.30-10.30 pm.; 6.065 SBG MOTALA, SWEDEN, 49.46 m. Relays Stockholm 1.30-6 pm.; 6.060 W8XAL CINCINNATI, OHIO, 49.6 m., Addr. Croesley Radio Corp. Relays WLW 5.30 am.-7 pm., 10 pm.-1 am.; 6.060 W3XAU PHILADELPHIA, PA., 49.5 m. Relays WCAU 7-10 pm.; 6.060 OXY SKAMLEBOAEK, DENMARK, 49.5 m. 1-6.30 pm.; 6.050 HJ3ABD BOGOTA, COL., 49.59 m., Addr. Colombia Broadcasting, Box 509. 12m.-2 pm., 7-11 pm.; Sun. 5-9 pm.; 6.045 HI9B SANTIAGO, D. R., 49.63 m. Irregular 6-11 pm.; 6.042 HJ1ABG BARRANQUILLA, COL., 49.65 m., Addr. Emisora Atlantico. 11 am.-11 pm.; Sun. 11 am.-8 pm.; 6.040 W4XB MIAMI BEACH, FLA., 49.65 m. Relays WIOD 12m.-2 pm., 5.30-6 pm., 10 pm.-12 m.; 6.040 W1XAL BOSTON, MASS., 49.65 m., Addr. University Club. Generally from 6-10 pm.; 6.040 YDA TANDJONGPRIOK, JAVA, 49.65 m., Addr. N.I.R.O.M., Batavia. 10.30 pm.-2 am.; Sat. 7.30 pm.-2 am.; 6.030 HJ4ABP MEDELLIN, COL., 49.75 m. 8-11 pm.; 6.030 HP5B PANAMA CITY, PAN., 49.75 m., Addr. P. O. Box 910. 12m.-1 pm., 7-10.30 pm.; 6.030 VE9CA CALGARY, ALTA., CAN., 49.75 m. Thur. 9 am.-2 am.; Sun 12 m.-12 m.; 6.030 OLR2B PRAGUE, CZECHOSLOVAKIA, 49.75 m. (See 11.875 mc.); 6.025 HJ1ABJ SANTA MARTA, COL., 49.79 m. 5.30-10.30 pm. except Wed.; 6.020 DJC BERLIN, GERMANY, 49.83 m., Addr. (See 6.079 mc.) 11.35 am.-4.30 pm.; 6.020 XEUW VERA CRUZ, MEX., 49.83 m., Addr. Av. Independencia 98. 8 pm.-12.30 am.; 6.018 ZHI SINGAPORE, MALAYA, 49.18 m., Addr. Radio Service Co., 20 Orchard Rd. Mon., Wed. and Thur. 5.40-8.0 am.; Sat. 10.40 pm.-1.10 am.; 6.015 HI3U SANTIAGO DE LOS CABALLEROS, D. R., 49.88 m. 7.30-9 am.; Sun. 12m.-2 pm., 5-7 pm., 8-9.30 pm.; 12m.-2, 5-6 pm.

Table with columns Mc. and Call. Entries include: 6.012 HJ3ABH BOGOTA, COL., 49.91 m., Addr. Apartado 565. 6-11 pm.; Sun 12m.-2 pm., 4-11 pm.; 6.010 VP3MR GEORGETOWN, BRI. GUIANA, 49.9 m. Sun. 7.45-10.15 am.; Daily 4.45-8.45pm.; 6.010 COCO HAVANA, CUBA, 49.92 m., Addr. P. O. Box 98. Daily 9.30 am.-1 pm., 4-7 pm., 8-10 pm.; Sat. also 11.30 pm.-2 am.; 6.005 HP5K COLON, PAN., 49.96 m., Addr. Box 33. 7.30-9 am., 12m.-1 pm., 6-9 pm.; 6.005 CFCX MONTREAL, CAN., 49.96 m., Can. Marconi Co. Relays CFCF 6 am.-11.15 pm.; Sun. 9 am.-11.15 pm.; 6.005 VE9DN DRUMMONDVILLE, QUE., CAN., 49.96 m., Addr. Canadian Marconi Co. Sat. 11.30 pm.-2 am.; 6.000 ZEA SALISBURY, RHODESIA, S. AFRICA, 50 m. (See 6.147 mc., ZEB.); 6.000 RV59 MOSCOW, U.S.S.R., 50 m. Irregular.; 5.990 XEBT MEXICO CITY, MEX., 50.08 m., Addr. P. O. Box 79-44. 8 am.-7 am.

↑ S.W. BROADCAST BAND ↑

Table with columns Mc. and Call. Entries include: 5.970 HJ4ABD MEDELLIN, COL., 50.26 m., Addr. La Voz Caria. 8-11.30 pm.; 5.968 HVJ VATICAN CITY, 50.27 m. 2-2.15 pm. daily; Sun. 5-5.30 am.; 5.950 HJN BOGOTA, COL., 50.42 m. 6-11 pm.; 6.940 TG2X GUATEMALA CITY, GUAT., 50.5 m. 4-6, 9-11 pm.; Sun. 2-5 am.; 6.930 YV1RL MARACAIBO, VEN., 50.59 m., Addr. Radio Popular, Jose A. Higuera M., P. O. Box 247. Daily 11.43 am.-1.43 pm., 5.13-10.13 pm.; Sun. 9.13 am.-3.13 pm.; 6.925 HH2S PORT-AU-PRINCE, HAYTI, 50.63 m., Addr. P. O. Box A103. 7-9.45 pm.; 5.917 YV4RP VALENCIA, VEN., 50.71 m. Irregular.; 5.900 TIMS PUNTARENAS, COSTA RICA, 50.85 m. 6-10 pm.; 5.898 YV3RA BARQUISIMETO, VEN., 50.86 m., Addr. La Voz de Lara, 12 m.-1 pm., 6-10 pm.; 5.890 JIC TAIHOKU, FORMOSA, 50.93 m. Works Tokio 6-9 am.; 5.885 HCK QUITO, ECUADOR, 50.98 m. 8-11 pm.; 5.875 HRN TEGUCIGALPA, HONDURAS, 51.06 m. 1.15-2.16, 8.30-10 pm.; Sun 3.30-5.30, 8.30-9.30 pm.; 5.855 HI1J SAN PEDRO DE MACORIS, D. R., 51.25 m., Addr. Box 204. 12 m.-2 pm., 6.30-9 pm.; 5.853 WOB LAWRENCEVILLE, N. J., 51.26 m., Addr. A. T. & T. Co. Works Bermuda nights.; 5.850 YV1RB MARACAIBO, VEN., 51.28 m., Addr. Apartado 214. 8.45-9.45 am., 11.15 am.-12.15 pm., 4.45-9.45 pm.; Sun. 11.45 am.-12.45 pm.; 5.830 TDD SHINKYO, MANCHUKUO, 51.46 m. Works Tokio 6-9 am.; 5.830 TIGPH SAN JOSE, COSTA RICA, 51.5 m., Addr. Alma Tica, Apartado 800. 11 am.-1 pm., 6-10 pm. Relays TIX 9-10 pm.; 5.800 YV5RC CARACAS, VEN., 51.72 m., Addr. Radio Caracas. Sun. 8.30am.-10.30pm. Daily 7-8 am., 10.45 am.-1.30 pm., 4-9.30 pm.; 5.790 JVU NAZAKI, JAPAN, 51.81 m. Irregular.; 5.780 OAX4D LIMA, PERU, 51.9 m., Addr. P. O. Box 853. Mon., Wed. and Sat. 9-11.30 pm. 8-9.30 pm.; 5.758 YNOP MANAGUA, NICARAGUA, 52.11 m. 8-9.30 pm.; 5.740 TGS GUATEMALA CITY, GUAT., 52.26 m. Wed., Thur. and Sun. 6-9 pm.; 5.730 HC1PM QUITO, ECUADOR, 52.36 m. Irregular 10 pm.-12 m.; 5.720 YV2RB SAN CRISTOBAL, VEN., 52.45 m., Addr. La Voz de Taehira. 6-11.30 pm.; 5.500 TI5HH SAN RAMON, COSTA RICA, 54.55 m. Irregular 3.30-4. 8-11.30 pm.; 5.145 PMY BANDOENG, JAVA, 58.31 m. 5.30-11 am.; 5.077 WCN LAWRENCEVILLE, N. J., 59.08 m. Addr. A. T. & T. Co. Works England late at night irregularly.; 5.025 ZFA HAMILTON, BERMUDEA, 59.7 m. Works N. Y. C. irregularly at night.

(Continued on page 193)

(All Schedules Eastern Standard Time)

QUESTION BOX SHORT WAVE

EDITED BY G. W. SHUART, W2AMN

● Because the amount of work involved in the drawing of diagrams and the compilation of data, we are forced to charge 25c each for letters that are answered directly through the mail. This fee includes only hand-drawn schematic drawings. We cannot furnish "picture-layouts"

or "full-sized" working drawings. Letters not accompanied by 25c will be answered in turn on this page. The 25c remittance may be made in the form of stamps, coin or money order. Special problems involving considerable research will be quoted upon request. We cannot

offer opinions as to the relative merits of commercial instruments. Correspondents are requested to write or print their names and addresses clearly. Hundreds of letters remain unanswered because of incomplete or illegible addresses.

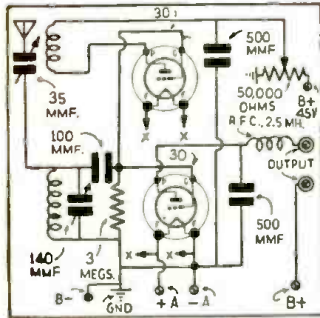

Separate Regeneration Tube 1077

SEPARATE REGENERATION TUBE

John C. Wilson, Ontario, Canada.
(Q.) I would like to employ two type 30 tubes in the detector section of my receiver; one as a separate regeneration tube and the other as a grid-leak detector. Will you kindly print the diagram in the *Question Box*.

(A.) We have shown the diagram of the 2 type 30 tubes one employed as a detector and the other as a separate regeneration tube. The two grids are connected in parallel, however, the tickler is connected in the plate circuit of the regeneration tube, while the audio output is taken from the plate circuit of the detector tube only.

BLUEPRINTS

Morris Goldstein, Newark, N.J.
(Q.) On page 604 of the February 1936 issue of *Short Wave and Television* there appears a diagram of a 4-tube receiver which does work for a 6-tube set. I am interested in building this set and would like to know how I could obtain a list of parts and a complete blueprint.

(A.) All available data is given in the article. We have no diagrams other than those published in the magazine.

2-TUBER WITH 3-WINDING COILS

W. B. Anderson, Fernie, B.C.
(Q.) Will you please print in a coming issue of the *Question Box* a diagram of a receiver employing two type 30 tubes, with Hammarlund 3-winding plug-in coils.
(A.) The diagram we have shown is conventional and the primary winding, that is the coil

which is interwound with the grid coil, is employed for antenna coupling. In addition, we must employ a small variable condenser in series with the antenna, because this ungrounded coil provides too much antenna coupling.

6L6 MODULATOR

J. R. Leakey, Syracuse, N. Y.
(Q.) Please print in your *Question Box* a Class "B" modulator using the following metal tubes. 6C5 into 6F6 into 6L6's push-pull. Is this a suitable modulator unit for a "53" xtal osc. 6L6 G buffer feeding into a pp. 6L6 G final? If not, please print a modulator that is.
(A.) A complete modulator employing the tube line-up referred to in your question was described in the November 1936 issue of *Short Wave Craft* on pages 394 and 395. Such a modulator would serve very nicely to modulate a pair of 6L6 tubes as a push-pull final amplifier.

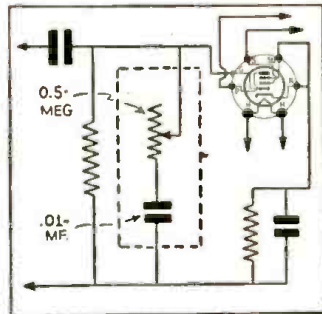

Tone Control Circuit 1079

TONE CONTROL

Al Beck, Erie, Pa.
(Q.) I recently constructed an A.C. set using a 58 T.R.F., a 57 as regenerative detector, a 56 as driver and a resistance coupled 2A5 as final output, which operates a dynamic speaker very well. Having obtained excellent results with this set, I wish to add a tone control for the broadcast band. Will you kindly show a good tone control hook-up I could use in this set?
(A.) It is very simple to add a tone control to your receiver or any receiver for that matter. Merely connect a 1/2 meg. variable resistor in series with a .01 mf. condenser. These are then connected between the Grid and B negative side of the circuit, as shown in the accompanying sketch. If the resistance is decreased the tonal response is lowered, attenuating with higher frequencies.

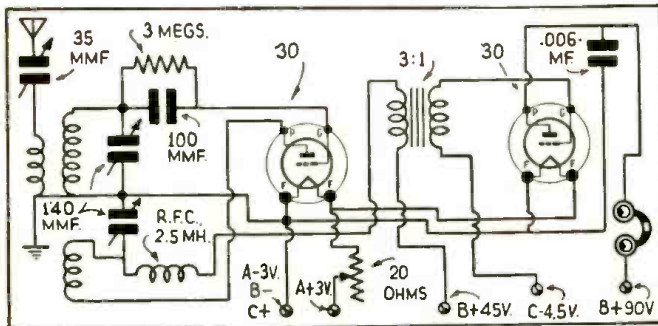

2-Tube Battery Set With 3-Winding Coils 1078

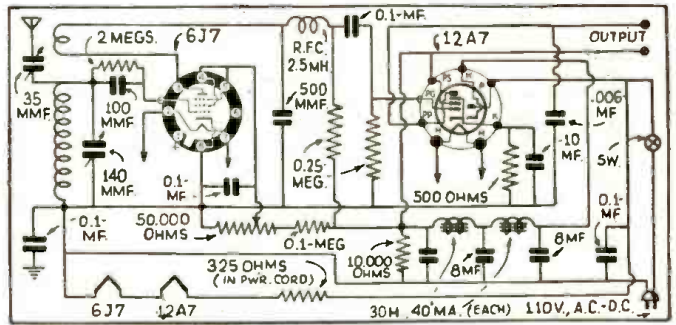

2-Tube A.C.-D.C. Receiver With Combination Pentode Amplifier and Rectifier 1080

B. F. OSCILLATOR

James Summers, Alexandria, Ind.
(Q.) I am a regular reader of your magazine and would appreciate it very much if you would publish a diagram of a beat frequency oscillator, suitable for use in conjunction with a 1936 Wings model 777.

(A.) On page 555 of the January 1937 issue of the *Question Box*, you will find a description together with a diagram of a suitable beat frequency oscillator. The diagram is No. 1034.

"HAMS" WON'T VERIFY

Paul Stevens, Peoria, Ill.
(Q.) I have written hundreds of letters to various amateur stations all over the world including the United States, requesting QSL cards, but very few of these have been answered, and I've been wondering if it would not be a good idea to publish something about it in *Short Wave & Television*. An answer through your *Question Box* might be in order since it is read by everyone.

(A.) The question which you have brought up is a very delicate one, and there is undoubtedly a good argument in favor of each side. However, being a "Ham," we can answer your question from the "Hams" point of view. The writer has received as many as 15 requests in one day, and many of these from foreign countries. Of course, the reports are usually very definite and enlightening and we answered those which are really "worthwhile" reports. Some cards, however, are hastily scribbled on small pieces of paper and are really not worth answering because the information contained is very incomplete.

PENTODE AMPLIFIER

Joseph Folland, Weldon, Sask.
(Q.) I have recently constructed the 2-tube receiver using type 30 tubes and have obtained excellent results with it. However, I now desire to add a 33 pentode amplifier, in order to obtain speaker volume. Will you kindly print a diagram showing transformer coupling.
(A.) We have shown the diagram and have correctly marked the various terminals. The two primary connections of the transformer connect to the phone posts of your present receiver. The terminal marked "P" on the transformer should go to the plate of the first audio amplifier, while the other terminal marked "B" will go to the plate supply lead.

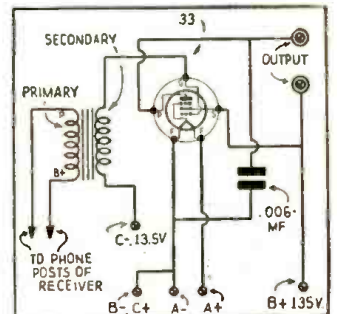

Pentode Amplifier for Battery Set 1081

NEW SHORT WAVE APPARATUS

PROMPT SHIPMENT ON ALL ITEMS



EILEN RX19 7-Tube Bandspread Receiver

8 1/2 to 3000 Meters

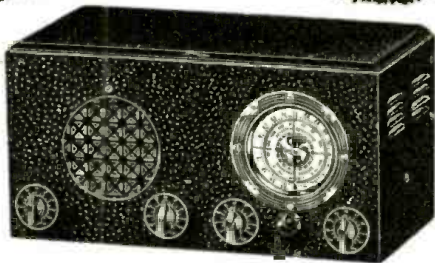

ER-19, complete, READY TO USE, with 7 RCA or Sylvania tubes. 12 low-loss silver plated coils for 8 1/2 to 3000 meters, wired, in cabinet, and instructions.

(If metal tubes are preferred over the glass type, add \$1 to above price.)

\$21.95

Our largest, finest, and most sensitive new 1937 receiver, unequaled in appearance, performance and value. Uses a special, highly efficient and selective circuit producing results which WILL satisfy even the most discriminating short wave fan.

ER-19 is equipped with the famous EILEN NOISE SUPPRESSOR, the latest development of our laboratories and which is skyrocketing itself into immense popularity. This remarkable development, exclusive with EILEN, constructed of the finest materials and to conform with the highest engineering standards, exclusive with EILEN. Two 6K7G, two 6J5G, one 6CG, one 4Z, and one 5Y3 high gain tubes as TUNED RF AMPLIFIER. This instrument uses TRON COUPLED SCREEN-GRID REGENERATIVE DETECTOR, powerful 3 stage audio frequency amplifier with Type 42 amplifier tube output stage delivering 3 watts peak of audio power to the built-in high fidelity dynamic loudspeaker. VARIABLE NOISE SUPPRESSOR, rectifier and complete built-in HUM-FREE power supply. BANDSPREAD tuning—a special electron tube circuit enabling the operator to reduce or eliminate certain types of noises or interchangeable inductors—doublet or aerial-ground connections—POWERFUL high fidelity audio system—large, illuminated airplane type vernier dial—sensitivity, volume, and selectivity that will amaze you—are features to be found in ER-19.

ER-19 in BEAUTY, as well as performance, is in a class by itself—heavy steel cabinet with hinged lid finished in durable black shrivel—colored dial lights behind black and white scale—chrome plated escutcheon—calibrated dial plates—plated chassis and shielding—Operates entirely from your 105 to 130 volts AC house current.

ER-19 under fair conditions will bring in dozens of foreign as well as domestic short wave stations with enormous volume. Order one and see for yourself.

For those who wish to build their own we offer:
 KIT of all parts, coils for 8 1/2-3000 me. **\$14.95**
 Tubes, un-wired (less tubes & cabinet)..... \$2.50
 Cabinet, extra..... 3.35
 7 matched Sylvania tubes, extra..... 3.35
 Wired and tested, extra..... 2.00

AMATEURS: Model ER-19-B has same specifications as ER-19, except that it is equipped with plate voltage cut-off switch and special bandspread coils for 20-40-80-160 M bands spreading these bands 80% of dial scale. Add \$1 to price of ER-19. (10 meter band coils if desired extra \$1.45.)



BS-5

6-Tube Band switch Receiver

10 to 600 Meters

A powerful, sensitive, and selective SW receiver covering the entire wave-length span of 10 to 600 meters in 5 steps. NO PLUG-IN COILS are used. Simply turn the waveband selector switch and enjoy reception on any wavelength within this range.

Uses two 6D6, one 76, one 4Z, one K42A, and one 25Z5 tubes as RF amplifier, electron coupled screen grid regenerative detector, powerful 2 stage audio amplifier with pentode output stage, rectifier, and complete built-in power supply.

HUM-FREE—Hi-fidelity dynamic loudspeaker—illuminated, airplane type vernier dial—band spread tuning control—automatic headphone jack—extremely smooth acting controls—operates from your AC house current—beautiful heavy, black shrivel finish chassis and cabinet.

DELIVERS GREAT LOUDSPEAKER VOLUME ON THE GREAT MAJORITY OF SHORT WAVE FOREIGN STATIONS UNDER FAIR CONDITIONS.

PRICE, complete with 6 tubes, cabinet, wired, and instructions, ready to use.....



See editorial article Page 482, Dec. issue S.W.C. House current. Simple to build and easy to operate. Beautiful, black shrivel finish cabinet and instructions furnished. Wave-length range 12-600 meters. An ideal set for the beginner who wishes to learn the thrill of short wave reception.

\$16.95

BEAM POWER TUBES TO BE HAD

BS-5 KIT, of necessary parts, including detailed instructions; less tubes, cabinet, un-wired..... **\$10.95**
 SPECIAL: Complete kit, cabinet, tubes and instructions, un-wired..... **\$14.95**
 (If metal tubes are preferred to glass type, add \$1)

AMATEURS: Model BS-5-AB has same specifications as BS-5 except that it has special bandspread circuit for 20-40-80-160 M bands and is equipped with plate voltage cut-off switch. Add \$1.00 to above price.

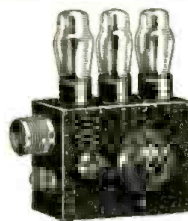

3-Tube Short Wave Radio

Only \$3.25

(less tubes, phones, un-wired)

A REAL, powerful 3 tube short wave set that readily brings in amateurs, police calls, broadcast stations, experimental and foreign stations with good volume under fair conditions. THE WORLD AT YOUR DOOR!

THREE TUBE BATTERY SET, less tubes, phones, un-wired \$2.95
 TWO TUBE BATTERY SET, less tubes, phones, un-wired \$2.00

KITS wired, extra 75c. Tubes, each 50c. Broadcast band coils (2), extra 95c. Cannonball double headphones \$1.35.



NEW! The HF-25 Beginner's Transmitter
 An inexpensive transmitter capable of delivering a good 20 watts crystal power to the antenna on the 160, 80, 40 meter bands and 15 watts on 20 meter band. Using the new 6L6G in a Tri-Tet circuit allowing operation on two bands with one crystal. Highest grade parts mounted on metal chassis housed in a beautiful crackle finished cabinet, antenna tuning unit built in. Eilen silvered transmitting dials. Triplet meter, including set cathode and plate tank coils for any one band. Specially priced at \$11.95. In kit form, including all parts necessary to put in operation except accessories listed below.
 Extra: 6L6G \$1.25. Quartz crystal \$1.95 for 80, 160 meter band, 40 meter \$2.50. Crystal holder \$1.00. Coils for additional bands \$1.00 per set.

NEW! The Last Word in SHORT WAVE RECEIVERS

Model RX 20

An 8 Tube 6L6 Beam Power Audio Electrical Bandspread Receiver. 2 1/2 to 3000 Meters

Our latest development, An 8-tube receiver for the AMATEUR and Short Wave fan, using a tuned R.F. Stage and tuned Electron coupled regenerative detector. Covers all wavelengths now in use including the ultra high frequencies and experimental bands. A gain control for the entire receiver is included. 5 WATTS OF AUDIO POWER AVAILABLE FOR THE BUILT IN HIGH-FIDELITY DYNAMIC SPEAKER.

For the HAM we offer type AB. Special Band Spread coils covering all the ham bands with individual padding control. Each coil are included in this model. Also a stand by switch for use during transmission periods. The phone jack is included which automatically cuts out speaker. Built in hum free power supply.

READY TO USE FACTORY WIRED AND TESTED INCLUDING TUBES AND BAND SPREAD COILS FOR THE HAM BANDS AND 200 TO 3000 METERS GENERAL COVERAGE

Uses the following tubes: 6K7G tuned R.F. amplifier, 6K7G tuned electron coupled detector, one 6J5G ultra high frequency oscillator tube. Two 6CG5 audio amplifiers, one AUDIO OUTPUT TUBE and a 5Y3G rectifier.

For the Short Wave Fan: RX-20R complete as above with coils from 2 1/2 to 3000 meters \$28.95.
 For the Amateur: RX-20AB complete as above with special amateur bandspread coils and 200 to 3000 meter coils \$29.95.

RX-20AB Amateur Kit: Includes all parts factory assembled ready to wire no holes to drill or parts to mount and schematic and picture diagram and a beautiful cabinet. KIT OF PARTS, \$19.95. Tubes, \$4.50 EXTRA. Special band spread coils \$1.00 per band for any one ham band.

RX-20R S.W.L. KIT: Same as amateur kit but with regular coverage coils from 2 1/2 to 3000 meters. KIT OF PARTS, \$19.75. Tubes, \$4.50, EXTRA.



7C 5-Tube Short Wave Receiver

8 1/4 to 625 meters



Bigger and More Powerful Than Ever A Giant in Performance

FULL 6 TUBE PERFORMANCE plus THE NEW K92A SERIES TUBE makes this an outstanding value. Equipped with a powerful 3 stage audio frequency amplifier. Uses 6D6-6P7 (twin 2 in 1 tube)—7K-K92A-12A7 (twin tube) tubes as R.F. amplifier, electron coupled screen grid regenerative detector, powerful 3 stage audio amplifier with pentode output stage, rectifier and complete built-in power supply. Operates entirely from 105 to 130 volt AC or DC light socket.

BAND SPREAD TUNING—smooth regeneration control—built-in high quality loudspeaker—automatic headphone jack—large, illuminated airplane type vernier dial—large low-loss inductances. Heavy, black shrivel finish metal chassis and cabinet. Must be seen to be appreciated. Satisfied owners report as high as 35 foreign countries on the loudspeaker with this model. You may do the same under fair conditions. ORDER YOURS TODAY! YOU WILL NOT REGRET IT!

EILEN 7C RECEIVER, wired, in cabinet, complete, READY TO USE, with speaker 5 RCA tubes, 4 coils for 8 1/4 to 200 meters, and simple instructions..... **\$12.95**
 2 Broadcast Band Coils, extra..... **\$1.25**
 7C KIT, un-wired, of necessary parts 4 coils for 8 1/4 to 200 meters, and instructions less cabinet, speaker, tubes..... **\$7.25**
 Beautiful metal cabinet, extra..... **\$1.25**
 Special loudspeaker..... **\$1.15**
 (2) Broadcast band coils, 200-625 meters..... **1.25**
 Kit for wiring & testing, extra..... **1.50**
 SPECIAL: COMPLETE KIT, un-wired, in-cabinet, 5 tubes, speaker, 4 coils for 8 1/4 to 200 meters, and simple instructions..... **\$11.45**
 2 broadcast coils, extra..... **\$1.25**

AMATEURS: Model 7C-AB, same specifications as 7C except that has special tuning circuit and coils for spreading out the 20-40-80-160 M bands over 80% of dial. Also equipped with plate voltage cut-off switch. Same price as 7C. Model 6B or 6B-AB h.t. batteries. Same price.

Prompt service. 20% deposit on C. O. D. orders
 Dept. SC 8, 136 Liberty Street, NEW YORK, N. Y.

Free
 New Latest CATALOG
 of short wave receivers, transmitters, & 5 meter apparatus. Send stamp to cover mailing costs on YOUR copy.
JUST OFF THE PRESS

EILEN RADIO LABORATORIES

Please mention SHORT WAVE & TELEVISION when writing advertisers

A "WORLD-BEATER"

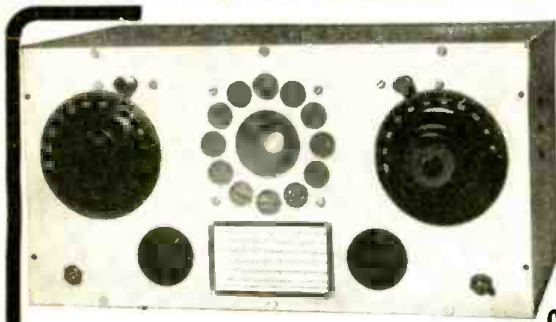

The NEW ACE DO-ALL

DE LUXE SEVEN TUBE HIGH PERFORMANCE COMMUNICATIONS RECEIVER

The ONLY Receiver incorporating ALL of these DESIRABLE FEATURES!

- **TWO TUNED STAGES**
A positive necessity for extreme sensitivity and "split-hair" selectivity.
- **LATEST TUBES**
6K7—Tuned R.F. Amplifier
6K7—Tuned electron coupled regenerative detector.
7B—U.H.F. 2 1/2 to 10 meter super regenerative detector.
7B—6CSG-6L6 HIGH Fidelity three stage audio power Amplifier.
5Y4G—Full wave, high voltage rectifier.
- **HEAD PHONE JACK**
Automatic, complete speaker cut-off—
- **NOISE SUPPRESSOR**
A remarkable development pioneered by Ace Laboratories. Positive switch control suppresses interfering noises, bringing out the foreign stations with tremendous volume.
- **2 1/2 to 3000 METERS**
Your Do-All is never obsolete. It accurately matches for today and tomorrow!
- **BEAM POWER**
New 6L6 Beam Power tube makes available 6 Watts Clear, crisp audio output, and loud speaker volume on all foreign stations.
- **DUAL REGENERATION**
An exclusive Ace featured Semi-Automatic for peak reception. Manual setting control.
- **FULL BANDSPREAD**
Separates those weaker foreign stations!
- **AND—**
Velvet smooth, calibrated controls—Doublet or single antenna input—Self contained, HUMLESS! Power Supply—Metal tubes for lower background level—Dual Panel Illumination. Sensitivity, power, selectivity, quality unsurpassed by none!

FOR COMPLETE DETAILS

DO-ALL DELUXE STANDARD MODEL (9 to 3000 Meters) Six tube Receiver, complete with matched tubes, and cabinet. Nothing else to buy! (Not wired) Laboratory wired and tested, ready for you to attach antenna, plug into socket, and thrill to new and strange programmes! Price.....	\$1975 \$2175
If tubes, cabinet, and 200 to 3000 meter wavelength range are not desired at present you may deduct from the above prices.....	\$500
DO-ALL DELUXE ULTRA MODEL (2 1/2 to 3000 Meters) Seven tube Receiver, complete with matched tubes and cabinet. Ready to be wired. Laboratory wired and tested, ready to operate. The entire world of Radio at your command! Complete	\$2375 \$2625
If tubes, cabinet, and 200 to 3000 meter wavelength range are not desired at present you may deduct from the above prices.....	\$500

SPECIAL: An eight page instruction booklet is included FREE with every DO-ALL! including complete, easy, wiring and operating instructions, as well as useful and essential short wave information; check full of illustrations, diagrams, etc., etc. Booklet available for 25c, postpaid.

BATTERY OPERATION AC-DC FOR VACATION, CAMP, MOBILE THE "UNIVERSAL-SIX" TUBE RECEIVER

IMAGINE! A compact, self contained, sensitive receiver with real SIX TUBE performance that will operate on any AC or DC house line. Simply plug in a cable and—PIRESTO!—a completely battery operated set that you can use in your car, boat, or any other place! The same full toned loud speaker volume—the same thrilling foreign reception—the same ease of operation! No changes in wiring. Really TWO receivers for less than you would expect to pay for only one!



Look at this powerful tube line-up: Screen grid pentode RF stage—high gain regenerative detector—THREE STAGE high quality audio amplification with power pentode output—heater type rectifier and humless power supply. FULL SIX TUBE POWER from two dual "Twin" 6F7 tubes and heavy duty 3B and 1-V tubes!

And these features: Full bandspread 9 1/2 to 625 meters—self contained, good quality loud speaker—New Transmitter type tuning dial with dual speed friction drive—provision for headphones—Indirect panel illumination—Velvet smooth control of regeneration—operates entirely from any AC or DC house socket OR ON BATTERIES. Low current drain means long, economical life of tubes and batteries.

This receiver is easy to build—easy to operate—and it certainly pulls 'em in! Order your Universal Six now! You will be amazed at the full loud speaker volume of distant stations! Every set is fully guaranteed. Buy with safety!

ACE UNIVERSAL-SIX receiver with four tubes, cabinet, all coils, and built-in speaker. COMPLETE. Nothing else to buy. Not wired. Laboratory wired and tested, complete, ready to plug in. **\$1275** **\$14.50**

QUALITY ACE RADIO LABORATORIES VALUE 227 GREENWICH ST., Dept. C-8, NEW YORK CITY

QUALITY recommends

Condensers

by

WET . . . DRY
PAPER
MICA . . . THREMMER

Please Write for Details

SOLAR MFG. CORP. 599-601 Broadway New York City

IMPROVE the sound quality of your telephone receiver to give results of a dynamic speaker by attaching JARNAK'S EARCAP.

Mechanical, Static and Background noises greatly reduced.

Immediate delivery for Western Electric, Cannonball, Trimm, Kellogg, Solid, Globe, Brandes.

Baldwin, Radio Ear and Automatic Electric Co.

Send for illustrated literature giving complete information

Price \$1.75 each Earcap. Discount for quantities.

Paul Jarnak, Inventor and Manufacturer, Dept. S-8
65 West 83rd St., New York City

Elgin Air Roamer III

By Walter Lesnick

● SIMPLICITY of construction, plus the ability to reach out and pull in "DX" are the main characteristics of the Elgin Air Roamer III. Plug-in coils, the most efficient type of tuning system for this type of receiver, are employed.

Examination of the circuit will show that a minimum number of parts are utilized, in conjunction with a very efficient tube setup. A 6F7, combination triode and pentode is used to provide maximum detection and amplification to the 43 output tube. The controls are all located on the front panel of the receiver eliminating any necessity of reaching behind the receiver.

A 20 mmf. variable tuning condenser is used to tune the antenna, which at the same time acts as a vernier regeneration control. For regeneration a 50,000 ohm potentiometer, or a .00014 mf. condenser can be used with equal success.

The rectifier section consists of the conventional 25Z5 tube, using a dual 25 mf. condenser in conjunction with a 300 ohm choke. The panel, base and cabinet are all available commercially.

This article has been prepared from data supplied by courtesy of Try-mo Radio Co.

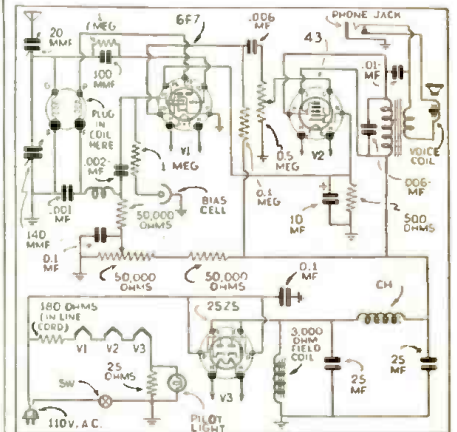

Hook-up of Receiver



Appearance of Elgin Air Roamer III.

Good News from Honolulu

(Continued from page 180)

subjects as A.V.C., Noise Silencer, and Noise Reducing Antennas.

I hope to construct a simple super, taking the diagram from Short Wave & Television.

I have heard quite a few countries such as England, Germany, Italy, France, China, Japan, India, Java, Siam, Australia, Fiji, etc. From this you can judge that your circuits work very well!

RICARDO MURAKAMI, 1014 Guller Ave., Honolulu, Hawaii.

Heard 275 "Ham" Stations and wish that some of you "Fans" or "Hams" would write.

PETER KUSHNER, Box 10, Hampton, Saskatchewan, Canada.

THE NEW R-9 SIGNAL BOOSTER!

GIVES THOSE WEAK DX SIGNALS A TREMENDOUS BOOST AND ACTUALLY REDUCES STATIC and NOISE!



Selectivity increased tremendously!
 Weak stations brought up to loudspeaker volume!
 A bandswitch preamplifier (4 bands—no plug-in coils) which can be used with any receiver. Tunes from 14 to 560 meters with overlaps on each band. If you are interested in long distance reception you need a signal booster regardless of what receiver you are using. The R-9 not only gives you extreme selectivity, preventing interference from other stations, but it gives you, at the same time, maximum regenerative amplification of the station you want *before* it even reaches your receiver.
 In ordering, specify what output tube is used in your receiver. R-9 SIGNAL BOOSTER with 6K7 tube complete in cabinet ready to operate. List price \$18.75.

SPECIAL EXPERIMENTER'S INTRODUCTORY PRICE..... **\$11.25**

R-S-R ⁵ TUBE CLIPPER DX-4 COMMUNICATION

4 TUBE RECEIVER



Beam power output 8 bands with individual coils
 Tremendous bandspread over entire range
 6K7 R.F. amplification on all frequencies
 5" calibrated tuning dial
 Headphone jack cuts out 6" dynamic speaker

A truly revolutionary receiver because never before has this class of set been available at such a price. 2½ to 560 meters—bandswitching—separate tank and bandspread condensers—straight AC operation with high voltage power pack built in—beam power output—dynamic speaker. Uses 2-6J5G, 1-6V6, 1-80 tube.
 The DX-4 is an exceedingly fine long distance receiver on all the short and ultra-short wave bands. There is no band capacity effect and it's great bandspread permits easy tuning and perfect separation of the stations.
 Incidentally, the DX-4 plus the R-9 SIGNAL BOOSTER makes a combination which for downright long distance reception is pretty close to "tops".
 DX-4 Complete with 4 tubes and cabinet, ready to operate from any 110 volt AC line **\$17.85**



5 TUBES, 3-1600 METERS

Tubes are cheap! If six or seven tubes would improve the operation of the CLIPPER we would use them. We do not load our sets with inefficiently operated tubes. When it comes to *real* DX; fewer tubes operated at peak efficiency bring in the signals at least as well and with less noise. The R-S-R CLIPPER has been constantly improved over a two year period by A. J. HAYNES, the designer, and we believe it is today undoubtedly the best bandswitch regenerative receiver obtainable regardless of number of tubes or price. It is our finest set and you will be proud of its performance.
 HAYNES R-S-R CLIPPER complete with 5 tubes and cabinet, ready to operate from 110 v. AC. line..... **\$28.85**

RADIO CONSTRUCTORS LABORATORIES
 Dept. SW-8, 136 LIBERTY ST., NEW YORK, N. Y.



only extends for a relatively short distance from the antenna, and is not important in the usual applications of radio.

When we come to a study of the radiation field as transmitted by waves through what is commonly called the ether, the current induced at a given receiving point falls off inversely as the distance, as we saw before. Also it is very important to remember that the amount of energy picked up by the receiving system located even a few yards from the transmitting antenna, is very small in comparison to the amount of power applied to the tubes in the transmitter. In other words, the transmission efficiency is very low. Added to this fact we have the rapid decrease in the amount of energy picked up as we move the receiving antenna system farther and farther away.

An interesting formula for computing the amount of current picked up in a receiving antenna is given below, and in this formula h_t denotes the height of the transmitting antenna, h_r denotes the height of the receiving antenna; I_t indicates the current flowing in the transmitting antenna; R indicates the resistance of the receiving circuit; W is the wavelength in meters and d is the distance between the two antenna systems (all dimensions are in meters). I_r is the current flowing in the receiving circuit.

Lighting Lamp by S-W Radio

(Continued from page 166)

$$I_r = \frac{188 h_t h_r I_t}{R W d}$$

This formula is a simple basic one for waves passing through free space and does not take into consideration the reduction of wave intensity (or attenuation) by absorption of the radiated energy in the surface over which the wave travels. This absorption effect can be computed approximately by a special formula which is given in many of the textbooks on the subject and is well-known to the advanced radio student.

It is interesting, in passing, to note that if, for example, a field strength of 200 millivolts per meter is established at a distance of one mile from a certain radio transmitting station (a broadcast station, for example), that at a distance of two miles the theoretical field strength would be 100 millivolts. At a distance of 3 miles the field strength would be 66.6 millivolts.

Nikola Tesla has devoted a great part of his life-work to researches in the radio transmission of power, and those interested will do well to look up some books on the subject in their public library, particularly

the book (now out of print) entitled—“Wireless Telegraphy—Its Origin, Developments and Apparatus” by Charles Henry Sevall. Two of Dr. Tesla's patents on “Methods and Apparatus for the Wireless Transmission of Energy,” and copies of which can be obtained at ten cents each from the United States Patent Office, Washington, D. C., bear the following numbers: 645,576, and 649,621.

As pointed out by several eminent radio engineers during the past few years, we still seem to be a long way from solving the radio transmission of power problem and thus there is plenty of research left for the young student just starting out on his radio career.

\$25.00 FOR GOOD 1-TUBE SET

● WE are offering \$25.00 for a good 1-tube set, either in the form of a short-wave receiver or a converter. Please note that there is little use in sending in an ordinary hook-up for a 3-element tube as most of the circuits possible with these tubes have been published.

What the editors want is a *new* circuit, designed around one of the latest type tubes having a multiplicity of grids.

Please mention SHORT WAVE & TELEVISION when writing advertisers

the NEW 1938 Super Sky Rider

5 to 550 Meters



**\$99⁰⁰ Less Speaker
Less Crystal**

- ✓ 5 to 550 Meter Coverage
- ✓ 6 Bands
- ✓ 11 Tubes
- ✓ Wide Range Variable Selectivity
- ✓ 1,000 Electrical Band Spread
- ✓ "5" Meters
- ✓ Air-trimmed RQ Circuit
- ✓ Improved Crystal Filter Control

Here's a receiver that has everything! Complete coverage from 5 to 550 meters, with a 5 meter band that's "hot." A new Band Spread of over 1,000 degrees that really permits you to "spread them out." Wide range variable selectivity (razor-sharpness to true high fidelity) and an overall sensitivity of better than 1 micro-volt. All this in one precision-built receiver at an exceptionally favorable price. Available on Hallicrafters Liberal Time Payments. See this outstanding new receiver today!

Stop in to see it or write for complete information.

HARRISON RADIO CO.

12 West Broadway
NEW YORK CITY

Lorenz Short-Wave Beam Lands Planes Blind!

(Continued from page 164)

then further reduce his altitude and prepare to bring his machine down safely on the field, even when ground visibility is at its worst.

This system is used in many of the European countries with great success. In the recent demonstration at Indianapolis, which was given under the auspices of the International Telephone & Telegraph Corporation, several planes were fitted with special Lorenz receiving apparatus and gave numerous demonstrations of "blind landing." The glass in the pilots' cockpit was coated with lime, and only a small opening was left clear for the emergency (second) pilot, so that if anything should go wrong, he could see the ground and bring the plane down safely in the usual way.

In the ordinary set-up of the Lorenz system, a sufficient number of transmitters are employed to provide landing in either one of two directions—east or west

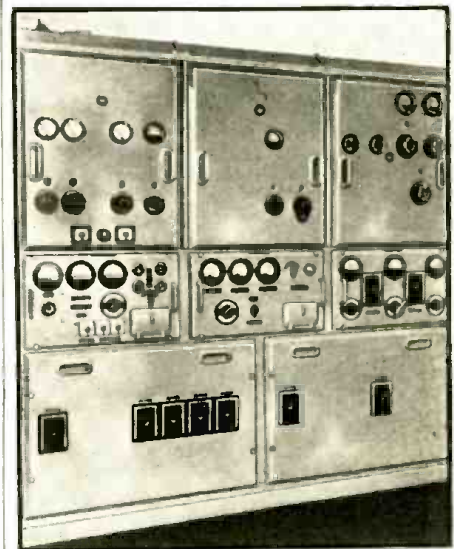

Radio guide beam transmitter installed at Indianapolis airport.

for example. As four choices for landing are common in this country, either a sufficient number of transmitters and also antennas may be employed to take care of this situation, or else a rotating beacon may be arranged, placed under heavy glass in the center of the field.

All of the transmitters are controlled by a push-button placed in the "control station" at the airport.

The general approach to an airport equipped with a short-wave landing beacon is interesting. By means of the tone modulated signals radiated by the main

ON TELEVISION AND SHORT WAVES . . .

TWO GREAT BOOKS

Hundreds of readers of SHORT WAVE AND TELEVISION with long term subscriptions complained to us because we offered the two books, ABC OF TELEVISION and SHORT WAVE GUIDE, only with subscriptions. THEY WERE NEVER SOLD.

In view of the importance of these books to short wave and television fans we have decided to make them available to our readers, at the nominal cost of fifty cents each, only for a very short time. YOU NOW HAVE THE OPPORTUNITY TO BUY THESE BOOKS . . . WE SUGGEST YOU ACT PROMPTLY BECAUSE WE CANNOT GUARANTEE THE OFFER TO BE REPEATED NEXT MONTH. Use the coupon below to order.

ABC OF TELEVISION

This book contains only the latest material available on Television. It is written by a well-known radio authority.

PARTIAL CONTENTS OF ABC OF TELEVISION
The simplest television receiver; how the eye sees—Theory of scanning; the Nipkow disc

and its relation to television; the photo-electric cell; neon lamps; brief description of several modern mechanical systems—Need for a large number of picture elements; need for broad channel widths in transmission of high-fidelity television signals—The use of the cathode-ray tube in television receivers; necessary associated equipment used in cathode-ray systems—How a television station looks and operates—The Iconoscope as used for television transmission in the RCA system—The Farnsworth system of television transmission—The future of television.

64 PAGES—100 ILLUSTRATIONS. STIFF, FLEXIBLE COVERS, 5 1/4 x 8 1/4 INCHES.

50c Postpaid

SHORT WAVE GUIDE

It is an excellent book—recommended by short-wave enthusiasts everywhere.

PARTIAL CONTENTS OF SHORT WAVE GUIDE
SHORT-WAVE QUESTIONS AND ANSWERS—SHORT-WAVE KINKS. Illustrated—HOW TO BUILD A SIMPLE SHORT-WAVE RECEIVER—WHICH IS THE BEST TYPE OF AERIAL TO USE?—A SIMPLE "HAM" TRANSMITTER—All the details, including list of parts, wiring diagrams and constructional details in building a simple "ham" transmitter will be found in this book—PRACTICAL HINTS ON SHORT-WAVE TUNING.

64 PAGES—196 ILLUSTRATIONS STIFF, FLEXIBLE COVERS, 5 1/4 x 8 1/4 INCHES. 50c Postpaid

ADD THESE BOOKS TO YOUR TECHNICAL LIBRARY!

Here are two fine books which the Editors of SHORT WAVE AND TELEVISION have written for you. Each volume brings you new, as well as important developments in each field. Read these books, not just once, but over and over again . . . you'll find them a big help.

SHORT WAVE & TELEVISION
99-S Hudson Street, New York, N. Y.



MAIL COUPON TODAY!

SHORT WAVE & TELEVISION
99-S HUDSON STREET, NEW YORK, N. Y. 8-37

Gentlemen: Enclosed you will find my remittance of \$..... for which please mail to me POSTPAID, the book or books indicated below:

- ABC OF TELEVISION @ 50c
- SHORT WAVE GUIDE @ 50c

Name

Address

City

State

Send remittance in form of check, money order, or unused U. S. postage stamps. (Foreign: International Postal Money Order.) Register letter if you send cash.

EVERY RADIO FAN WANTS TO READ THEM!!

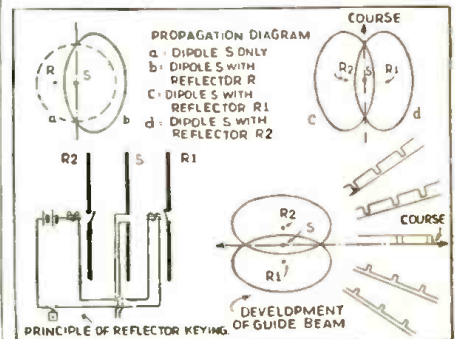

This diagram shows the overlapping wave patterns radiated progressively by the main beam transmitter of the Lorenz landing system.

Please mention SHORT WAVE & TELEVISION when writing advertisers

beacon, the pilot reaches the approach path by means of this beacon. For the reception of the beacon signals an automatically operating receiver is used, which furnishes the pilot with both an aural and visual indication of the position in the horizontal plane of the machine with respect to the guiding beam of the radio beacon. The approach path sector is defined by the intersection of two ra-

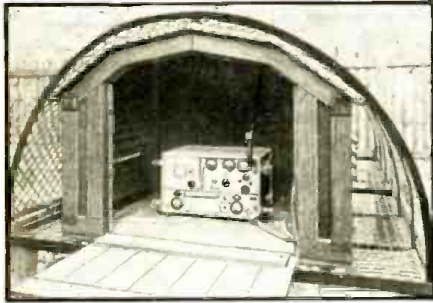

A signal transmitter erected in wooden hut under the reflector arch.

diation patterns produced by the alternate operation of two reflector dipoles.

Should the airplane be outside of this approach path, short dots are heard on the port side, or dashes on the starboard side. Divergencies of the course are again indicated both aurally and visually. By intermittent deflections to left or right of the received signal, the indicating instrument shows the direction in which the pilot should steer his machine in order to reach the approach path in which the (complementary) signals, by merging into one another, become a continuous note. At the moment when the continuous note is reached, the direction indicator comes to rest and indicates to the pilot that he should maintain his course for a safe landing at his destination.

With the Lorenz system, the ground equipment includes a 500 watt guide beam beacon transmitter, together with two or four 5-watt transmitters for the transmission of the signals, according to whether one or two directions of an approach flight are provided for. The frequency of the main beacon transmitter is 33.3 mc.

Sargent Marine Type Receivers



Model 12

Known the world over as a standard Marine communication receiver. Built for 24 hour continuous service. Rugged, sensitive, selective, tunes 15 to 9000 meters, operates directly from ship's power or from emergency batteries. Band spread, break-in connections, every feature demanded in an up-to-date marine installation.



Model 11

The personal receiver of hundreds of radio operators, sailing the seven seas. Universal Model tunes 9.5 to 20,000 meters. Marine Model 9.5 to 3,750. Available for A.C., D.C., 6 volt or 2 volt battery operation. Band spread, coil switching, and all other advanced features. One of the best C.W. receivers ever built,—very good on phone and broadcast also.



Model 100

Write for full data on these receivers

Immediate Delivery

E. M. SARGENT CO.,
212 9th Street, Oakland, Calif.

The marker beacon signal transmitters employ an operating frequency of 38 mc.; the modulation frequency for the "outer marker" beacon is 700 cycles per second and for the "inner marker" beacon is 1,700 cycles per second.

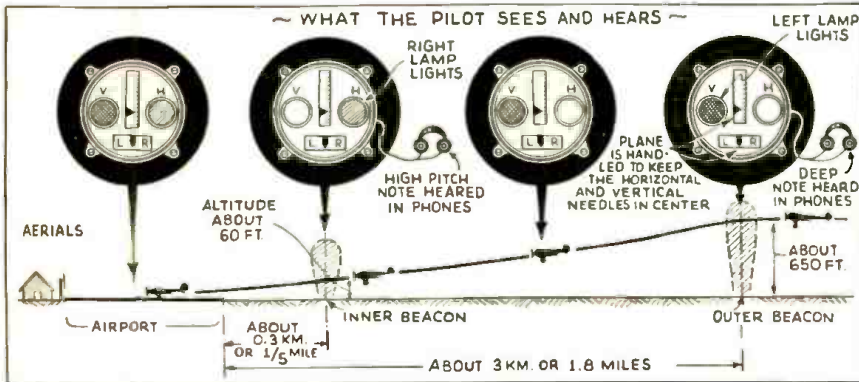

Progressive indications on the special meter mounted before the pilot in the plane's cockpit are shown above. All the pilot has to do is to keep the vertical and horizontal "indicators" in the centers of the respective scales and "fly down the beam" to a landing on the airport.

World S-W Station List

(Continued from page 187)

6.000	TFL	REYKJAVIK, ICELAND, 60 m. Works Europe nighttime irregularly.	4.600	HC2ET	GUAYAQUIL, ECUADOR, 65.22 m., Addr. Apartado 249. Wed. and Sat. 9.15-11 pm.
4.975	GBC	RUGBY, ENG., 60.3 m. Works ships irregularly.	4.272	WOO	OCEAN GATE, N. J., 70.22 m., Addr. A. T. & T. Co. Works ships irregularly.
4.820	GDW	RUGBY, ENG., 62.24 m. Works N.Y.C. nighttime irregularly.	4.250	RV15	KHABAROVSK SIBERIA, U. S. S. R., 70.42 m. 1-10 am.
4.790	VE9BK	VANCOUVER, B. C., CAN., 62.63 m., Addr. Radio Sales Service, Ltd. 780 Beatty St. Except Sun. 11.30-11.45 am., 3-3.15, 8-8.15 pm.	4.107	HCJB	QUITO, ECUADOR, 73 m. Daily 7.30-8.45 am. Daily except Mon. 11.30 am.-2.30 pm., 5-7 pm., 7-10 pm.
4.752	WOO	OCEAN GATE, N. J., 63.1 m., Addr. A. T. & T. Co. Works ships irregularly.	4.098	WND	HIALEAH, FLORIDA, 73.21 m., Addr. A. T. & T. Co. Works Bahamas Irregular.

Please mention SHORT WAVE & TELEVISION when writing advertisers

SEE YOUR JOBBER



PLUG and SOCKET CONNECTOR

SPRING CABLE PROTECTOR

MODEL D-104

Favorite of the Amateur

A quality crystal microphone especially adaptable for voice transmission. Output level —54 DB (conservatively rated). New redesigned case. List Price \$22.50.

Licensed under Brush Development Co. Patents.

ASTATIC Microphone Laboratories, Inc.
Dept. SW YOUNGSTOWN, OHIO

ASTATIC

FREE HAMS SEND FOR YOUR NEW FREE BUYING GUIDE



Crammed with bargains! Everything in ham parts and equipment! It saves time and money. It's got what you need! Write for FREE Catalog No. 66-4 H7.

WHOLESALE RADIO SERVICE CO., INC.
104H SIXTH AVE. NEW YORK, N. Y.

New 1937 Hum Free Power Supply Pack



This pack will supply 2 1/2 or 6.3 filament V (Please specify) up to 8 tubes. Supplies pure rectified 110 volt, 350 Volt at 90 Mils. 6 Ampe. filament. "B" supply tapped at 45, 90, 180, and 250. Well filtered; extra heavy chassis. Complete kit with wiring diagram and drilled chassis. Less tubes wired—50 extra, tube—rectifier tube \$3.95 —40 extra—Shipping weight 27 lbs.

5 BAND ALL WAVE COIL SUPER-HEAT KIT

5 Band All Wave Tuning Assembly 42-000 K.C. to 550 K.C. (7 to 600 meters). Completely assembled and wired. Complete set, an all wave Super-Heat, YA XLEY single knob band switcher. Unit Completely wired with all connections soldered. Can be installed in your present receiver by connecting extra and plates of 2 tubes. Size of unit 8 1/2" x 12 1/4". AD6969—tuning unit assembled and wired. O.U.I. Price—\$4.95. Complete instructions and diagrams. Extra—5c. This unit can be made into a 10 tube set. Kit of parts—10 tube set \$11.96. Kit of tubes \$6.35. Less speaker, chassis and dial. Magic eye tuning unit \$1.00 extra. Magic eye tube 90c extra.

6 Tube 15 Watt Amplifier Kit

This high grade amplifier kit sold to you in a knock-down form at the lowest prices ever sold. A real 2A3—15 Watt amplifier with complete kit of parts. Chassis complete, drilled and ready to put together. Easy to assemble by means of our lattice working blue print. Complete—\$6.95. Tubes—\$2.15. Maltroy 10 mfd.—300 V. filter condensers 15c



Shipping wt 70 Lbs. AD471

BRUNSWICK BREMER-TULLY 6 tube battery console radios: 1 dial, completely shielded radio circuit using 3 stages R.F. Utilizes 201A and 171A tubes. 4 tuning stages, single control. Size of chassis 15 1/2 x 10 x 7. Shipping weight 78 lbs. Complete in console cabinet. Size of Console—21 x 40 x 14 1/2. Brand new factory sealed cases. We suggest freight shipments. AD6669 \$4.95

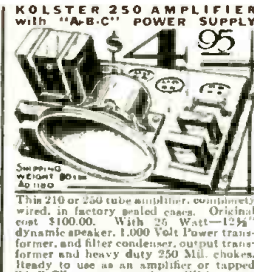

Shipping wt 10 Lbs. AD471

\$1.00 Tube Sale \$1.00 Tube Sale

Table listing various tube types and quantities for sale at \$1.00 each.

KOLSTER 250 AMPLIFIER WITH "A-B-C" POWER SUPPLY

This 210 or 250 tube amplifier, completely wired, in factory sealed case. Original cost \$100.00. With 25 Watt—12 1/2" dynamic speaker, 1,000 Volt Power transformer, and filter condenser, output transformer and heavy duty 250 Mli. chassis. Ready to use as an amplifier or tapped "A-B-C" power supply. With every amplifier, we furnish free, a diagram for converting this into a 15 Watt High Gain P.A. System. Ideal for restaurants, theatres, factory calling systems, etc.

Ultra-Short-Wave Possibilities

By Baron M. von Ardenne (Continued from page 163)

possessed any worth-while knowledge of broadband (aperiodic) R.F. amplifiers. The modulation and demodulation of broad frequency bands was then a novelty. The specific conditions of ultra-short-wave propagation in large cities, their range, and the field strength obtainable in the chaos of buildings and structures had to be tested and, last but not least, co-axial cables were something still to be designed.

The past seven years have changed the situation entirely. The tremendous strides of television have caused a considerable evolution in respect to ultra-short-wave technique, and it pays to reconsider the proposition made seven years ago.

Transmitters with large output powers, which permit radiation of broad frequency bands, are already in operation in a number of large cities. Most of them are utilized during only a small part of the day for image transmission; because of the well-known difficulties of providing suitable program material. Therefore, no tremendous engineering difficulties would be encountered by making experiments with the multiplex modulation.

One needs only to impress upon the terminals of the video (image) amplifier the modulation voltages of a number of "programs," to be provided by studio presentations, or by pickup of DX stations as described above. Finally, another proposal:—when these programs are rebroadcast, with the identical frequencies radiated by the far-flung DX transmitters, one could tune them in on the broadcast receiver at exactly the same spots where these stations would appear on the tuning dial were direct pick-up possible.

Calculations have indicated that about five different programs could be radiated by means of a single ultra-short-wave beam, without incurring the possibility that the energy allotted to each program would become too small.

Also, at the receiving end one need not expect fundamental difficulties. The video (image amplifier) part of a television receiver (but without the output stages) could be used as a converter. Since these sound-broadcast transmissions are to be radiated only at times when there are no image transmissions, no disadvantages need occur because of the utilization of the video-part of the television receiver for this type of sound transmission. This discussion shows that the proposal here made can easily be accomplished with the means at present at our disposal.

Perhaps it is still too early to present this proposal again. It is possible that this idea will be appreciated and consummated five or ten years from now, when television receivers in great numbers will be in use; thus permitting us to utilize ordinary broadcast receivers to hear multiplex sound transmission by means of ultra-short waves.

New CBS Television Station

(Continued from page 168)

likewise from the Farnsworth and Philco transmitters in Philadelphia. The proposed CBS television transmitter will operate with a peak power of 30 kilowatts, which is equal to that of the new transmitter being built for the Eiffel tower television station in Paris. The Columbia station will have an active average radius of 40 miles or cover a circle about 80 miles in diameter. This coverage is equivalent to about 4,800 square miles. The precise operating frequency we are advised by the CBS engineers has not been determined just yet, but it will be in either the 42 to 56, or the 60 to 86 megacycle bands. The image will be broadcast on one frequency and the voice on another, both in the high frequency region.

UNITED RADIO CO., 58 MARKET ST., DEPT. S-8, NEWARK, N. J.

ELGIN AIR ROAMER "3" 3-Tube Receiver. Features: Airplane Dial, Vernier Regeneration Control, 9 1/2-2000 Meters, Earphone Jack. Completely outclasses any receiver of similar design.

Image of the Elgin Air Roamer radio. Chassis only with 3 tubes \$11.70. Matched grey wrinkled cabinet \$1.25.

TRY-MO RADIO CO., INC., 85 Cortlandt St., New York City, N. Y.

AT 10 P. M. KIND NEIGHBORS SHUT OFF LOUDSPEAKER... Cannon-Ball HEADSETS. Favorite Set of "Hams". Heavy bat magnets built into Cannon-Ball Phones greatly increase efficiency—will satisfy you. C. F. CANNON COMPANY SPRINGWATER, N. Y.

New ACR-111 (Continued from page 184) The loudspeaker is a separate unit attached to the chassis by means of a cable with a seven-prong plug-in connection. It is assembled on a small wooden mounting in which holes are provided for fastening to a large baffle when high-quality reproduction is required. This article has been prepared from data supplied by courtesy of RCA Mfg. Co.

New Earphone Cap (Continued from page 184) phragm in certain frequency ranges, which tends to reduce the third harmonic distortion caused by the resonant effects of the diaphragm. The inventor also claims that, due to this effect, the lower frequencies and fundamental frequencies of the various sounds imposed upon the diaphragm are brought out much clearer. Tests with a pair of these caps attached to a standard brand of earphones proved that there was a substantial increase in fidelity, the reproduction being more natural and distinct. These earphones are made in various sizes to fit all standard brands of earphones. This article has been prepared from data supplied by courtesy of Paul Jarnak.

STOPPANI COMPASS A Precision Instrument Made in Belgium. Purchased by the U. S. Government at more than \$30.00 each. Ideal for Radio Experimenters Laboratory, also may be used as a Galvanometer for detecting electric currents in radio circuits. Ruby jeweled, solid bronze, 4 inches square, fitted in a hardwood case. Also used by hunters and surveyors. Our price prepaid \$4.50 each. GOLD SHIELD PRODUCTS 99 Hudson St., 11th Floor New York City

Please mention SHORT WAVE & TELEVISION when writing advertisers

The S.W.&T. Communications Receiver

(Continued from page 173)

portion between 315 and 390. The entire 40 meter band is spread from 250 to 420, and the 20 meter phone band from 260 to 330. The 10 meter band, as well as the 20 meter CW portion, is also spread out in a similar fashion; one division is approximately 1/4 inch.

Regeneration

In order to obtain regeneration in the first detector circuit, a small winding must be added to the FB-7 detector coils. If care is exercised in taking the padder out of the coil, the job is really easy and can be done in short order. Merely place a hot soldering iron against the two prongs to which this padder is connected and it can be easily removed. This small cathode coil is wound just below the "B" minus end of the grid coil. In some coils there is space enough on the large portion of the form and on others this regeneration coil will have to be wound in the narrow slot at the bottom of the form. Complete data as to the number of turns is contained in the coil table. This coil should be wound in the direction opposite to that of the grid coil. Fortunately, there was a prong in the FB-7 detector coil, only five prongs were originally used. The blank prong is used for the cathode terminal, the other end of the coil is soldered into the prong used for the "B" negative side of the grid coil. An additional hole has to be drilled in the back of the mounting shields, that is, the shield can which supports the coil socket, in order to bring out this cathode lead. There already are five holes in the can corresponding to the five prongs used for the coil.

Selectivity

Naturally, with the extreme selectivity obtained at the regenerative detector stage, a panel trimmer will be needed. This condenser should have a maximum capacity of from 10 to 15 mmf. The lower the capacity used, the better because its adjustment is really critical. A change of two or three degrees will nearly eliminate an R-7 signal. This condenser will require a slight re-adjustment when changing from one end of a given band to the other; however, the circuits "track" excellently, and once an optimum setting is found, it need not be touched unless an extremely weak signal is being dealt with. Likewise, an optimum setting of the regeneration control for any given band will easily be found and this also will need no adjustment except on extremely weak signals.

Antenna

The detector coil has a separate antenna winding both terminals of which are available for connection to a doublet. Best results, were obtained with a 50 mmf. condenser in series, with one leg of this coil connected to a single wire antenna with the other side grounded. The antenna which works satisfactorily for all amateur bands is a 66 ft. flat-top, tapped some 9 ft. off center, employing a single-wire feeder.

Of course, the oscillator coil needs no changing. A conventional 6J7 metal tube is used in the oscillator circuit. The use of an acorn tube here would not provide a noticeable improvement, inasmuch as the stability of this oscillator, even on 10 meters, is almost perfect. The method of injecting the oscillator voltage into the detector is a result of much experimenting. With the values shown this method provided a lower background level than any other of the several methods tried, with the result that the gain control can be run "wide open" with the receiver remaining absolutely quiet, insofar as receiver noise is concerned.

Incidentally, the secret of success in a receiver of this type is low receiver noise-level, and this receiver really has an extremely low background noise level. The urge may be felt to deviate from some of

the values shown, and even to employ different tubes and slight modifications of circuits; however, we strongly advise against this, because this receiver is really a perfect working job and we don't recommend changes. That is, if the performance of the original one is to be duplicated. If the builder desires a higher degree of selectivity a conventional quartz crystal of course, may be incorporated.

Reference to the photographs will give an idea of the layout used. In the bottom view you will notice a dotted circle and a shield can at the bottom of the chassis; an explanation may be necessary. After the receiver was finished the I.F. showed a tendency to go into oscillation with the AVC switch in the off position and the sensitivity control wide open. This was traced to the H.F. oscillator stage. Due to the wiring arrangement, the by-pass condensers and resistors for the oscillator stage were mounted beneath the chassis directly under the 6J7 tube. It seems that there was sufficient radiation from these parts to throw the I.F. stages into oscillation with the gain control full on. Placing a small shield can over all of these parts, (the by-pass condensers and the plate and screen resistors) cured the trouble. Then there was absolutely no sign of instability at maximum gain setting. With a slightly different arrangement in wiring employed in a duplicate of this receiver, of course, the results would be entirely different and there may be no tendency toward feedback. However, we mention this to show what a slight amount of oscillator radiation can do to a very high gain I.F. amplifier. In an effort to eliminate R.F. in the filament circuit one side of each heater in the tube is connected to ground, and this proved to be entirely adequate. However, in some cases it may be found necessary to by-pass the other leg of the heater circuit right at the first detector and oscillator sockets.

So far as instability in the high-frequency portion is concerned, this set leaves practically nothing to be desired. The regeneration control in the first detector circuit does not affect the tuning, of either the oscillator or first detector. Also the detector trimmer does not pull the oscillator. The entire high frequency portion is absolutely stable in all respects.

As for the sensitivity of the receiver, no measurements were taken and we will not attempt to estimate its sensitivity in microvolts. We will say this—from actual experience and comparison with other sets, it is not found wanting. During its operation we have not found a single signal that could not be brought up to an R-7 value, and we experienced no cases where we could hear signals but too weak to be copied. This is undoubtedly due to the low noise-level of the receiver, for anyone experienced with receivers will recall hearing stations, and many at that, which are too weak to be brought in. We found that if they can be heard at all on this receiver, they can be copied solid, providing there is no QRN or QRM.

Aside from being an efficient receiver, its appearance is also modern and business-like, especially with the National HRO dial and the HRO crackle finished cabinet.

Coil Data for "S.W.&T." Receiver

Band	Grid Turns	Cath. Tap	Osc. Coils			Wire
			B.S. Tap	Length	Winding	
80	34	7	13	1 1/2"	No. 24 enam.	
40	9	3	3 1/4"	5/8"	No. 24 enam.	
20	4	2	1 1/2"	1/2"	No. 24 enam.	
10	2 1/2	1 1/2	3/4"	1/4" space between turns	No. 22 enam.	

Band	Grid Turns	+ Cath. Coil	Det. Coils			Wire
			B.S. Tap	*Ant. Coil	Length Winding	
80	35	1 1/2	15	7	1 1/2"	No. 24 enam.
40	17	1	4 3/4"	3	1 1/2"	No. 24 enam.
20	8	1	1 1/2"	1 1/2"	1"	No. 24 enam.
10	2 1/2	1	series cond. used (35 mf.)	1 1/2"	1/4" space between turns	No. 22 enam.

*Interwound with B— end of grid coil. No. 30 d.c.e. wire.
+Wound in opposite direction to grid coil at B— end. No. 30 d.c.e. wire. (See next page—center col.)

Please mention SHORT WAVE & TELEVISION when writing advertisers

The Best "BUYS" Are Made For Cash!



● It costs a distributor or a dealer at least 5% to sell and handle tubes on any of the "no investment" finance plans. You, the dealer, have to pay this 5% or more... The depression is over and depression methods of doing business are rapidly becoming obsolete. That is why increasing thousands of dealers and service men are saving money and getting the highest quality tube by buying RAYTHEONS on regular terms.



ASK YOUR RAYTHEON JOBBER



445 Lake Shore Drive, Chicago, Illinois
555 Howard Street, San Francisco, Cal.
420 Lexington Avenue, New York, N. Y.
55 Chapel Street, Newton, Massachusetts
415 Peachtree Street, N. E., Atlanta, Ga.

RADIO INSTRUCTION

be a SKILLED Radio Operator!



CANDLER TRAINED T. R. McElroy, World's Official Champion. Speed 69 w.p.m. Champion McElroy says:

"The CANDLER SYSTEM is the only training I had for my championship code contests. It taught me to read code by sound as easily as I read print, and to put it down on my 'mill' by touch, as fast as it comes—without thinking of each code letter. Co-ordination and Concentration are necessary to the handling of code at all speeds. The CANDLER system in this respect is exclusive and scientific. I recommend it to those wanting to learn code right, as they'll be using it over the air, and to those who want speed."

You Will Be AMAZED at Your Speed and Technique after a Few Weeks of

CANDLER TRAINING

Code is easy to learn when you are taught the right way. The Famous Candler System always succeeds because it teaches you to read code by sound just as you read print by sight. It is the system through which the speed champions like McElroy and thousands of amateur and commercial experts have attained their marvelous proficiency. Your progress will be amazingly rapid with the Candler System—and surprisingly inexpensive. You'll actually enjoy your easy practice lessons—especially when you see such rapid development. In just a few weeks, Candler will have you pounding brass like the best of them.

THREE FAMOUS CANDLER COURSES Recommended by ALL CODE EXPERTS

SCIENTIFIC CODE COURSE for beginners. Teaches all the necessary code fundamentals scientifically

HIGH SPEED PROFESSIONAL TRAINING for operators who want to prepare themselves for the commercial radio field.

TELEGRAPH TOUCH-TYPE WRITING for those who want to become expert in the use of the "mill" in receiving fast stuff by touch!

FREE!

Book of Facts. Explains this amazingly simple system of learning code and developing speed quickly!



CANDLER SYSTEM CO.

Department S-8

Asheville, North Carolina, U.S.A.

What Modulator Power Should We Use?

(Continued from page 170)

peaks but reproduced the lower-level high-frequency tones with sufficient power to modulate our transmitter, we should have better intelligibility for the simple reason that our average level would have been raised, though actually they are reproduced even with 25% audio power. If our maximum peaks are reproduced for 100% modulation, we can see that our intelligibility is transmitted with an actual modulation percentage of somewhere around 25 to 50%. To us it would seem better to eliminate the peaks and raise the over-all articulation. Of course, when we eliminate these peaks we do change the character of the voice in that it loses some of its roundness or naturalness, but, on the other hand, today the amateur operating in crowded bands is more concerned with being understood and conveying the thought rather than obtaining broadcast quality and not being understood.

To illustrate the importance of the higher frequency low-level components, a filter was employed to eliminate all frequencies above 1,500 cycles per second, the articulation was reduced 35%, while the energy reduction was only 10%. To further illustrate this, we only have to recall what happens to the voice of an amateur station when a crystal filter is used in the receiver; it becomes very "drummy" and is in most cases very difficult to understand simply because most of the high-frequency low-level components have been eliminated and we are working with the high level low frequency peaks. A reversal of this receiving condition would seem to be in order, and it might be interesting to note in passing, that at the present time we are working on just such type reception and hope to have something interesting on it in the near future.

Getting back to our tube problem—competent tube engineers agree that the average vacuum tube employed in a class "B" amplifier, will reproduce these instantaneous peaks which are illustrated in fig. 1, without damage to the tube and with little danger of serious distortion. Overloading a tube in the class "B" amplifier will cause transients which in turn will create a rasping, rattling sound; however, the average amateur transmitter will not reproduce sounds much over 3,000 cycles, and therefore these transients will be of little consequence insofar as annoying sounds are concerned.

From what has been explained and illustrated previously, the reader will probably see the reason why many amateur phones are overmodulated. Despite modern equipment and modern operating technique, there are thousands of stations operating with modulation peaks greatly in excess of 100% modulation. Undoubtedly it is for the simple reason that the tube manufacturer states that a class "B" audio amplifier will deliver 100 watts with a plate current reading of 130 ma., as shown with a D.C. milliammeter, but does not mention the wave form. If the amplifier delivers 100 watts and modulates a 200 watt carrier input 100% with a sine wave and the average meter reading is 130 ma. and then we speak into the microphone and maintain that same average current reading on the meter, we are overmodulating to a very serious degree.

The writer clearly recalls working an amateur station who was doing this very thing; he could not understand why he was receiving complaints when he was "only pushing the plate current up to the rated value as specified by the manufacturer." As soon as he was informed as to the difference in the average values between the sine and the complex wave forms, the light appeared and no more overmodula-

\$100 for a RADIO KEY!!?

WORTH IT—but I only charge \$9.50

This semi-automatic key makes it easy to send! Dot stabilizer equipped. Selected metal spring. Martellite finish base stays put. Chromium metal parts. Proper height for tireless, rhythmic sending. New 1938 Mac Key only \$9.50—Order today! Also New Mac Straight Key—best ever—only \$2.49. Write for complete details on other Mac items of tremendous help to radio ops.

T. R. McELROY—175 Congress St., Boston, Mass. WORLD'S CHAMPION TELEGRAPHER

LEARN TO SEND AND RECEIVE CODE



Learn to send and receive code signals, like operators on ships at sea and at commercial and amateur land stations. Intercept distress signals, news flashes, bulletins, and dozens of other kinds of interesting radio communications.

TELEPLEX teaches you to receive code

exactly the way the world's best operators do—by sound. A heavy waxed paper tape, running through a machine, operates an automatic key which sends messages to you, at any speed you desire. As you improve in speed, the machine sends faster, gradually preparing you for top-speed amateur and commercial signals. With the new All Electric MASTER TELEPLEX you learn to send by sending, and the signals you send are repeated back to you, exactly as you send them, thus enabling you to correct your own errors. We furnish a complete course, lend you the All Electric MASTER TELEPLEX and give you personal instruction with a MONEY BACK GUARANTEE. Send for our new Teleplex Folder NS today. IT'S FREE!

TELEPLEX CO., 72-76 Cortlandt St., New York

RADIO ENGINEERING

TRI-STATE COLLEGE

DEGREE IN 2 YEARS.

Complete Radio Engineering Course in 96 weeks. Bachelor of Science Degree. Radio (television, talking pictures and the vast electronic field) offers unusual opportunities for trained radio engineers. Courses also in Civil, Electrical, Mechanical, Chemical, Aeronautical Engineering; Business Administration and Accounting. Low tuition, low living costs. World famous for technical two-year courses. Those who lack high school may make up work. Students from all parts of the world. Enter September, January, March, June. Write for catalog. 2587 College Ave., Angola, Ind.

The 10 meter detector coil is not tapped for handspread; a 35 mmf. padder is connected in series with tuning condenser; this padder is also inside of coil form as well as the 50 mmf. parallel padder. The small Padder (35 mmf.) is mounted with stiff wire, so that it can be adjusted through the hole in bottom of coil form.

Parts List for "S.W.&T." Super

- SPRAGUE**
- 18—.01 mf. high frequency condensers
 - 3—.0001 mf. mica condensers
 - 1—.005 mf. mica condenser
 - 1—.006 mica condenser
 - 2—10 mf. low voltage electrolytics
- I.R.C.**
- 4—50,000 ohm 1/2-watt resistors
 - 1—1,500 ohm 1/2-watt resistor
 - 5—10,000 ohm 1/2-watt resistors
 - 2—300 ohm 1/2-watt resistors
 - 1—1,000 ohm 1/2-watt resistor
 - 5—1/4 meg. ohm 1/2-watt resistors
 - 1—.1 meg. ohm 1/2-watt resistor
 - 2—.5 meg. ohm 1/2-watt resistors
 - 2—.1 meg. ohm 1/2-watt resistors
 - 1—500 ohm 1-watt resistor
 - 1—10,000 ohm 10-watt resistor
 - 1—50,000 ohm 10-watt resistor
 - 1—3,000 ohm 20-watt resistor
 - 1—20,000 ohm 20-watt resistor
 - 2—20,000 ohm potentiometers (one with switch)
 - 1—5,000 ohm potentiometer (with switch)
 - 1—50,000 ohm potentiometer
 - 1—250,000 ohm potentiometer
 - 1—500,000 ohm potentiometer
- NATIONAL**
- 1—PW-2 150 mmf. tuning assembly, with micrometer dial
 - 1—set each 80, 40, 20 and 10 meter FB-7 coils
 - 2—Octal tube sockets
 - 1—Acorn tube socket
 - 2—shield and socket assemblies for plug-in coils
 - 3—465 kc. iron core I.F. transformers
 - 1—beat oscillator assembly 465 kc.
 - 1—HRO cabinet
 - 1—15 mmf. midget trimmer
 - 1—50 mmf. midget trimmer
- RCA**
- 1—954 acorn tube
- RAYTHEON**
- 1—6J7 tube (isolantite)
 - 2—6L7 tubes (isolantite)
 - 1—6H6
 - 1—6N7
 - 1—6F6
- BRUSH**
- 1—Transfilter 465 kc.
- TRIPLETT**
- 1—small bakelite case meter 0-5 ma.
- MISCELLANEOUS**
- 5—Octal sockets (one hole mounting type)
 - 1—toggle switch

Please mention SHORT WAVE & TELEVISION when writing advertisers

RADIO INSTRUCTION

LEARN CODE RIGHT

Tapes for Every Need—Even Airways—Send you Typical Messages by INSTRUCTOGRAPH.
It's easy and practical to learn or improve your Radio or Morse Code, any speed. Senior Model with 10 Tapes and Junior Model with 5 Tapes and Book of Instructions—\$12.00 (Not mailed). Complete oscillator equipment, less battery, \$5.20. Send for details today to—



INSTRUCTOGRAPH CO., Dept. SW-8
912 Lakeside Place
Chicago,
Ill.

Canadian Representative: Radio College of Canada, 863 Bay St., Toronto.
WE ALSO HANDLE: HALLICRAFTER and R.M.E. SHORT-WAVE RECEIVERS—MICROPHONES—VI-BROPLEXES—TAYLOR TUBES. CASH OR TERMS.

tion occurred. This same condition also undoubtedly accounts for the 25% versus 50% argument. Amateurs have found that if they drive the plate current of the class "B" stage, to the manufacturers specifications, they can easily modulate twice as much carrier input as the modulating amplifier was normally intended to work with.

Of course, if we change from voice forms to sine wave forms and maintain the same average current in the plate circuit of our class "B" amplifier, we can only modulate this carrier input 70.7%.

We trust that this article will greatly clear up the modulation situation and explain why we can satisfactorily modulate 100 watts carrier input with an amplifier which is rated at 25 watts output with sine wave excitation.

Universal Receiver for the Trailer, Boat or Home

(Continued from page 186)

a motor-generator set, wind-charger, etc., or even taken from the automobile, constitutes the only necessary means of power supply.

The receiver consists of a 6-tube, 2-band superheterodyne receiver, of latest design. The band switching arrangement consists of a tapped coil arrangement in both the antenna and oscillator circuits, utilizing a two-circuit shorting switch, which shorts the broad-band section of the coils, reducing the inductance of same for tuning on short wave.

Field excitation for the speakers is obtained from a permanent magnet constructed of the new highly magnetized alloy specially designed for this purpose. The speaker cone suspension is of the full floating type exactly as used in A.C. receivers. The filament circuit of the receiver is so designed that for 110 volt A.C. operation, the filaments are automatically connected in series while switching over to the 6 volt D.C. position automatically connects all the filaments in parallel. The automatic volume control circuit is of the positive action type.

The power supply for a 6-volt operation consists of a plug-in type synchronous vibrator of the low current-drain variety, which is rubber mounted as an integral part of the power supply unit housing the vibrator transformer, condenser and chokes. When operated on 110 volt A.C. the 2525 half-wave rectifier tube acts as a voltage doubler and supplies approximately the same voltage to the receiver as does the 6 volt vibrator unit. Filament voltage control is accomplished in the receiver through use of a L49C ballast tube, which is necessary to prevent damage to the tubes due to the universal feature of the receiver.

The bands covered by the receiver are 16 to 58 and 193 to 550 meters.

This article has been prepared from data supplied by courtesy of Wholesale Radio Service Co.

New Portable "Duplex"

(Continued from page 186)

detector circuit is used, which sets new standards of selectivity and control.

Two high-gain stages of audio amplification are used to insure consistent loud-speaker operation. These are 1-6J7, first stage and 1-6F6, power output stage, which delivers 4 watts to the built-in dynamic speaker.

The A.C. power-supply is made up of a rugged power transformer and large filter chokes. A 500 volt paper condenser block is used for filtration. The rectifier is a 5Z3.

For 6 volt operation the power-supply is a 350 volt, 150 mil (M.A.) filtered generator.

This article has been prepared from data supplied by courtesy of Ultra High Frequency Products Co.



Amazingly Easy Way to Get into ELECTRICITY

Send Today for Details of

"Pay-After-Graduation" Plan

Don't spend your life never sure of a job. Let us prepare you for your start in a good paying field. Let us teach you how to prepare for positions that lead to good salaries in Electricity—NOT by correspondence, but by an amazing way we teach right here in the great Coyne Shops. You get a practical training in 90 days. Mail the coupon below. If you are short of money I'll send you all details of my "pay-after-graduation plan" where many get my training first and start paying for it 5 months after they start school and then have 18 months to complete their payments.

LEARN BY DOING—IN 90 DAYS BY ACTUAL WORK IN THE GREAT COYNE SHOPS

I don't care if you don't know an armature from an air brake—I don't expect you to! Coyne training is practical "learn-by-doing" training. Don't let lack of money hold you back from getting all details of my amazing plan.

MANY EARN WHILE LEARNING

If you need part time work to help pay your expenses, we may be able to help you as we have hundreds of others. When you graduate we'll give you lifetime employment service. And, in 12 brief weeks, in the great shops of Coyne, we train you as you never dreamed you could be trained . . . on one of the greatest outlays of electrical apparatus ever assembled . . . real dynamos, engines, power plants, autos, switchboards, housewiring, armature winding and many other branches of Electricity.

Electric Refrigeration Air Conditioning

Right now we are including additional instruction in Electric Refrigeration and Air Conditioning without extra cost so that your training will be complete and you can get into this marvelous, rapidly expanding field.

GET THE FACTS Coyne is your great chance to get into Electricity. This school is 38 years old—Coyne training is tested. You can find out everything absolutely free. Simply mail the coupon and let us send you the big, free Coyne book with photographs . . . facts . . . opportunities. Tells you how many earn expenses while training and how we assist our graduates in the field. No obligation to you. So act at once. Just mail coupon.

BIG FREE BOOK

Send for my big book containing photographs and telling the complete story—absolutely FREE.



COYNE ELECTRICAL SCHOOL

500 S. PAULINA ST., Dept. C7-83, CHICAGO, ILL.

H. C. Lewis, Pres., COYNE ELECTRICAL SCHOOL
500 S. Paulina Street, Dept. C7-83, Chicago, Ill.
Dear Mr. Lewis: Without obligation send me your big, free catalog with facts about Coyne Training and details of your "Pay-Tuition-After-Graduation" Plan.
Name Age.....
Address.....
City..... State.....

Get into RADIO REAL JOBS REAL PAY
RADIO AND TELEVISION INSTITUTE, Inc.
2130 Lawrence Ave., Dept. 21-C, CHICAGO, ILL.

Earn While Learning at Home!
TELEVISION, PHOTO ELECTRIC CELLS, PUBLIC ADDRESS PHILCO CROSLEY ZENITH GRUNOW and 48 other mfrs.
Many R-T-1 Trained Men make up to \$75 a week and more in full-time radio jobs—\$5-\$15 in spare time alone. More trained men needed. Learn at home by quick, easy, R-T-1, WAY. Endorsed by 50 big concerns. Write for big Opportunity Book, FREE. R-T-1

Learn SOUND RECORDING TALKING PICTURE PROJECTION TELEVISION-RADIO

Master training courses qualify you for good jobs. Practical, easy to learn. Newest equipment. Established 1905. Earn room and board while learning. Coach it. R. fare allowed to L. A. Write for FREE BOOK. Address Dept. S-SWC, 4000 S. Figueroa St.
NATIONAL SCHOOLS—Los Angeles

LEARN RADIO TELEVISION MIDLAND'S

Color-Coded Extension Training fits you for better radio jobs—prepares for future television opportunities. Backed by 5000-watt Columbia basic network broadcasting station, KMBC. Graduates qualified to take Government operator's license exams. Lifetime employment service. All necessary equipment for "home laboratory" experiments furnished. 90 illustrated lessons, 10 laboratory manuals. After "home training" bus ticket to Kansas City for 4 weeks intensive training in laboratories. Get facts—write for free catalog.
MIDLAND TELEVISION, Inc., Power & Light Bldg., 112 W. 14th St., Kansas City, Mo.

BE A RADIO SERVICE EXPERT

Modern receivers require men with modern training for service work
LEARN AT HOME
Our home instruction method and service equipment offer starts you earning money almost at once. Up to \$3 an hour easy in a short time. Write for free book.
Radio Training Ass'n of America
Dept. SWT-78
4525 Ravenswood Ave., Chicago

RADIO ENGINEERING

RCA Institutes offer an intensive course of high standard embracing all phases of Radio. Practical training with modern equipment at New York and Chicago schools. Also specialized courses and Home Study Courses under "No obligation" plan. Catalog Dept. SW-37.
RCA INSTITUTES, Inc.
75 Varick St., New York. 1154 Merchandise Mart, Chicago
Recognized Standard in Radio Instruction Since 1909

RADIO ENGINEERING,

broadcasting, aviation and police radio, servicing, marine radio, telegraphy and telephony, Morse telegraphy and railway accounting taught thoroughly. Engineering course of nine months' duration equivalent to three years of college radio work. All expenses low. Catalog free. School established 1874.
Dodge's Institute, Turner St., Valparaiso, Ind.

6 BACK NUMBERS 70c
SHORT WAVE & TELEVISION
MAILED PREPAID
For a limited time only, and as long as they last, we will send you six back numbers of SHORT WAVE & TELEVISION and SHORT WAVE CRAFT assorted, your choice, for 70 cents.
We accept U.S. stamps, U.S. coin, or money order. Rush your order today.
SHORT WAVE & TELEVISION
99-101 Hudson Street New York, N. Y.

Please mention SHORT WAVE & TELEVISION when writing advertisers

**Here's RADIO'S
"MONTHS-AHEAD"
CATALOG!**

**ALLIED'S 156-PAGE 1937
CATALOG SCOOPS RADIO FIELD!**

Here's a new book—a complete book—a book that makes all other catalogs obsolete! Packed with Everything in Radio that's months-ahead, it includes the latest Amateur transmitters, receivers and transceivers; dozens of Build-Your-Own kits; more than 10,000 exact duplicate and replacement parts; 53 new Super-Value Knight Radios; test instruments; Sound Systems; radio books, tools, etc. See what's new—see what's important in Radio!—Send coupon for this great book today!

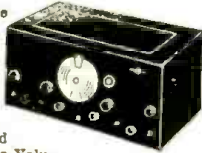

FASTER SERVICE—LOWER PRICES!

You save more—get more—profit more—when you order from ALLIED! Our complete stocks, central location, efficient buying and selling methods, and speedy shipping department mean faster service, lower prices and greater values for you. Make ALLIED—Radio's Leading Supply House—your single dependable source for high-grade radio supplies!

FREE Catalog



ALLIED RADIO Corp.

833 West Jackson Blvd., Dept. 3-H,
Chicago, Illinois.

Send me your new 1937 Catalog.

Name _____

Address _____

City _____

SPORT BINOCULARS



THESE Temple-Type Sport Glasses are the lowest-priced Binoculars ever offered. Something new for the Sportsman, Rancher, Traveler, Theatregoer, Sightseer. Ideal for Prize fights, Baseball games, Horse races, Football games, events, Tournaments, Arenas, Movies, Music Halls, Theatres, Operas, etc.

CAN BE WORN LIKE SPECTACLES!

Great for Indoor or Outdoor Sports, Vacation trips, Hunting, Fishing, Exploring, Aviation, Seashore, Ocean Travel, Mountain Climbing, Yachting, Boating, Hiking, Motoring, Camping, etc.

Very clear and powerful in defining distant objects. Handsome in appearance. High grade 3-power objective lenses of good optical quality with wide field of vision.

Individual focusing eyepieces adjustable for eyes of unequal vision. Best mechanical construction. The frame is of durable black composition; comfortable fitting lightweight temples and nose bridge.

STOCK NUMBER: S200. \$249
SPORTS BINOCULARS, Your Price

Sent postpaid anywhere in U. S. A.
Money back Guarantee.

WELLWORTH TRADING CO.
Dept. SWT-837
560 W. WASHINGTON BLVD., Chicago, Ill.

RADIOS..SAVE UP TO 50%

DEAL DIRECT...FACTORY PRICES! Many models to select from: AC-DC; All-Wave; Farm sets that operate like city radios! Your name and address on postcard brings you a NEW Bargain Catalog—colors FREE. Get details of 30-DAY TRIAL plan and appreciate proposition!

GOLDENTONE RADIO CO.
DEPT. C8, DEARBORN, MICHIGAN

Free Catalog

30 DAY TRIAL \$6.98 UP

BLILEY CRYSTALS

20-40-80-160 Meter Bands
\$3.95 up.
Bliley Electric Co., Erie, Pa.

SHORT WAVE LEAGUE



HONORARY MEMBERS

- Dr. Lee de Forest
 - John L. Reinartz
 - D. E. Replogle
 - Hollis Baird
 - E. T. Somerset
 - Baron Manfred von Ardenne
 - Hugo Gernsback
- Executive Secretary*

WHEN TO LISTEN IN

by M. Harvey Gernsback

(All Schedules in Eastern Standard Time)
ANENT "B.B.C." VERIS

● DUE to a misunderstanding we announced in the June issue, that Daventry now verifies and as proof, reproduced a veri card which purported to be from the British Broadcasting Corp. Since that time we have been informed that the Daventry station still does not verify.

What actually happened is this: Mr. Carroll H. Weyrich of 4310 Evans Chapel Road, Baltimore, Md., several months ago undertook to check each Daventry transmission several times each month and keep a complete "log" of its programs during a certain fixed period. Anyone picking up Daventry during these periods was to send his "log" to Mr. Weyrich; if the log checked with Mr. Weyrich's he would issue a confirmation card for any given frequency employed by Daventry. A charge of five cents was to be made for each frequency checked. These confirmation cards were printed at Mr. Weyrich's own expense and were not issued by the B.B.C. The service was originated as a courtesy to DXers. The card reproduced in the article on getting veries (page 73, *Short Wave & Television*, June, 1937) was actually one of Mr. Weyrich's. It was sent in to us and we believed it to be a real verification from the offices of the British Broadcasting Corp. This matter was called to our attention by Mr. Weyrich who regrets that any confusion was created.

HONGKONG

The Hongkong short-wave station, ZBW, announces that it no longer verifies.

U. S. S. R.

All U.S.S.R. telephone stations have discontinued verifying. The broadcasting stations will continue to issue verifications however.

CUBA

A newcomer to the air waves is COGF at Matanzas, operating on about 11.790 mc. This station has been testing at various times relaying CMGF. The station's signals are very strong and clear. Address is Box 51.

CO9JQ on 8.665 mc. has been heard testing and employing the call COJK.

PERU

Two additional Peruvian stations are reported by a Buenos Aires listener. OAX4Z at Lima on 6.092 mc. is supposed to be on daily from 7-11 pm. OAX4P at Huancayo on 6.122 mc. is supposed to operate daily from 8 pm. on.

DOMINICAN REPUBLIC

H11X, Ciudad Trujillo, 6.340 mc. operates on Sun. 7:40-10:40 am. Tues. and Fri. 12:10-1:10 pm. and 8:10-10:10 pm. Rest of week 12:10-1:10 pm.

H12X, Ciudad Trujillo, 11.960 mc. operates on Tues. and Fri. 8:10-10:10 pm.

H18X, Ciudad Trujillo, 15.280 mc. operates on Sun. 7:40-10:40 a.m. Balance of week 12:10-1:10 pm.

Here's Your Button

The illustration here-with shows the beautiful design of the "Official" Short Wave League button, which is available to everyone who becomes a member of the Short Wave League.



The requirements for joining the League are explained in a booklet, copies of which will be mailed upon request. The button measures 3/4 inch in diameter and is inlaid in enamel—3 colors—red, white, and blue.

Please note that you can order your button AT ONCE—SHORT WAVE LEAGUE supplies it at cost, the price, including the mailing, being 35 cents. A solid gold button is furnished for \$2.00 prepaid. Address all communications to SHORT WAVE LEAGUE, 99-101 Hudson St., New York.

AWATEA

ZMBJ, the station aboard the ship *Awatea*, in service across the Tasman Sea between Australia and New Zealand no longer broadcasts. It is used only for telephone service now. Scrambling equipment is used. Our thanks to Jas D. Watson of Palmerston North, New Zealand, for this information.

NEW YORK

W2XE of the Columbia broadcasting System has raised its power to 40 kw.



Short Wave League

At a Directors Meeting held in New York City, New York, in the United States of America, the Short Wave League has elected

John F. Müller

a member of this League.

In Witness whereof, this certificate has been officially signed and presented to the above.

H. Winfield Secor
Club Secretary

This is the handsome certificate that is presented FREE to all members of the SHORT WAVE LEAGUE. The full size is 7/4"x9 1/2". (See page 202.)

Please mention SHORT WAVE & TELEVISION when writing advertisers

For the S-W Beginner A Novel "Regen." 2-Tuber

(Continued from page 171)

iron and resin-core solder. All lead holes in the chassis, especially the grid and screen-grid lead holes, must be large— $\frac{3}{8}$ inch at the least. Do not use the metal chassis as a common "ground" return; connect all of the negative terminals together by means of a single piece of insulated wire and solder this to the chassis at one point only. This eliminates the poorly soldered connections and high-resistance returns which might result if this precaution is not observed.

Operation Hints

The operation of the set is simple. Connect the heater and "B" supply voltages, as shown in Fig. 1, and an antenna and ground to their respective leads. The antenna should be short for best results—25 or 30 feet being a convenient length. Set the tuning dial at about 50 and rotate the band-setting condenser until the desired band is heard. Adjust the band-setter to the center of the band and tune in the stations with the dial in the usual manner. The exact amount of "spread" obtained will depend somewhat upon the band in use and the adjustment of the band-setting condenser. On the 19, 25 and 31 meter broadcast bands and the 20 meter amateur band, the spreading is about twenty to forty degrees on the 270 degree dial; the 49 meter broadcast and the 40, 80 and 160 meter amateur bands are spread the full 270 degrees.

Although the 6.3 volt tubes are shown in connection with the set, it is not absolutely necessary to use these. The tubes in the 2.5 volt series or battery-operated tubes can be used with equally as good results. The parts values remain the same in either case.

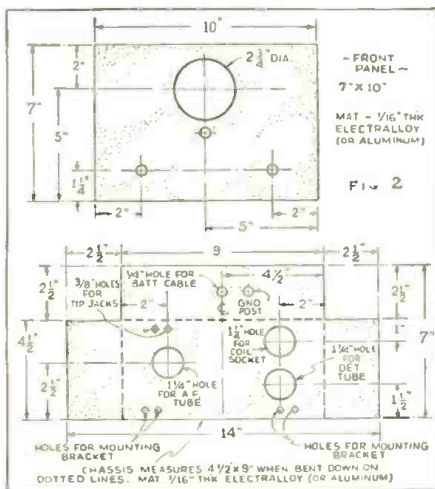

Panel and Sub-Panel Layouts.

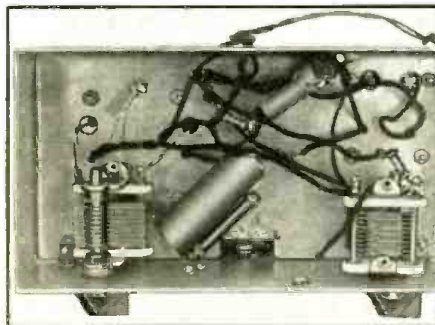

Bottom View of Receiver.

Please mention SHORT WAVE & TELEVISION when writing advertisers

20 Instruments in One



The Allmeter is the Season's Biggest Sensation!

Price is **\$10⁴⁰**
Only

The Allmeter, a 1,000-ohms-per-volt d'Arsonval instrument, instead of being just a volt-ohm-ammeter, is such an instrument plus a.c. readings for voltages and currents, also accurately measuring very low resistance, from below one ohm, also high resistance, capacity, henries and decibels, comprising twenty instruments in one. For a.c.-d.c. use.

0-15-150-750-volts and milliamperes, a.c. and d.c.

-12 to +30 decibels .03-500 ohms
500-500,000 ohms 5-1,000 henries
.01-50 mfd. Continuity Tester

Incomparable Signal Generator

Our new generator has the following features:

1. Direct reading in frequencies, 100 kc—22 mc, in five bands, all fundamentals, by front-panel switching. Ultra band by harmonics to 105 mc, also direct-reading.
2. Direct reading in frequencies, 25-10,000 cycles, in three bands, all fundamentals, by front-panel switching.
3. R.F. and A.F. outputs independently obtainable alone, or with A.F. (any frequency) modulating R.F.
4. Output meter.
5. R.F. attenuation.
6. Condenser and other leakages to 100 megohms.
7. Main dial protracted on $7\frac{1}{2}$ " diameter, precision pointer 4-to-1 vernier planetary drive.
8. All services on 90-130 volts a.c. or d.c.

\$14⁴⁰
PRICE



Send for our Free Catalogue PV in colors!

SUPERIOR INSTRUMENTS COMPANY 136 LIBERTY STREET
Dept. SW-8, New York, N. Y.

- List of Parts—2-Tube Set**
HAMMARLUND MFG. CO.
One 140 mmf. tuning condenser
One 20 mmf. tuning condenser
One 250 mmf. tuning condenser
One set four or six prong XP-53 plug-in coils
One 35 mmf. trimmer condenser
One isolantite socket, metal-tube 8-prong type
One isolantite socket, 4 or 6 prong type (for coils)
One R.F. choke, 2.5 mh. Midget type
- CORNELL-DUBILIER**
One mica condenser, 0.0001 mf.
One mica condenser, 0.001 mf.
One mica condenser, 0.006 mf.
One paper condenser, 0.01 mf., 400 w.v.
One electrolytic condenser, 10 mf., 50 w.v.
- AEROVOX**
One 3 meg. resistor, carbon, $\frac{1}{4}$ watt
One 0.5 meg. resistor, carbon, $\frac{1}{4}$ watt
One 0.25 meg. resistor, carbon, 1 watt
One 0.1 meg. resistor, carbon, 1 watt
One 500 ohm resistor, carbon or wire-wound, 2 watts or larger.

- CHASSIS**
One 7x10 inch electralloy panel
One $4\frac{1}{2}$ x9 inch chassis (see text)
One bakelite socket, metal-tube 8-prong type
Two head-phone tip-jacks

- DIAL, Etc.**
One 270 degree airplane dial, counter-clockwise, $\frac{1}{4}$ inch shaft
Two "Change-O-Name" dial plates, 180 degree calibration
Two pointer type knobs

COIL DATA

Range Meters	Grid Turns	Tickler	Primary—Spacing Wire
135-270	82	16	47 $1\frac{1}{4}$ " No. 28
66-150	38	11	25 $1\frac{1}{2}$ " No. 26
33-75	18	6	11 $1\frac{1}{2}$ " No. 24
17-41	9	5	6 $1\frac{1}{2}$ " No. 16
9-20	$3\frac{1}{2}$	3	2 $1\frac{1}{2}$ " No. 14

All coils wound on $1\frac{1}{2}$ " ribbed forms. Space between grid coil and tickler $\frac{1}{4}$ ". Spacing is length of winding. Primary is wound between turns of grid coil. All ticklers wound with No. 30 D.S.C. wire.



Used by U. S. Government—
Airways—Broadcasting Stations
—Radio Engineers and Amateurs
the World Over.

World's Largest Makers of Antenna Systems

L. S. BRACH Mfg. Corp.

Newark, N. J.  Est. 1906

CHASSIS—CABINETS PANELS & CANS

STANDARD SIZES ON HAND
SPECIAL SIZES MADE TO ORDER
KORROL RADIO PRODUCTS CO.

Dept. S-8
232 Greenwich St., New York City

THEN



NOW

C-D DYKANOL CAPACITORS

With the development of Dykanol in the laboratories of Cornell - Dubilier, previous manufacturing concepts of oil capacitors were completely changed. Not only was it possible through the use of this impregnating medium to reduce the weight and size of these capacitors by fully 60%, but also, to considerably increase the already high quality standard of C-D oil capacitors. For complete dependability standardize on C-D Dykanol capacitors. Utilized by leading manufacturers of radio equipment; U. S. Army, Navy, Signal Corps, and other government divisions; and wherever uninterrupted operation is essential. Today! Ask your local C-D authorized distributor to show you the salient features of these capacitors. Catalog No. 137A free on request.



CORNELL-DUBILIER
CORNELL-DUBILIER CORP.
1002 HAMILTON BOULEVARD - 30, PLAINFIELD, NEW JERSEY

AT LAST!

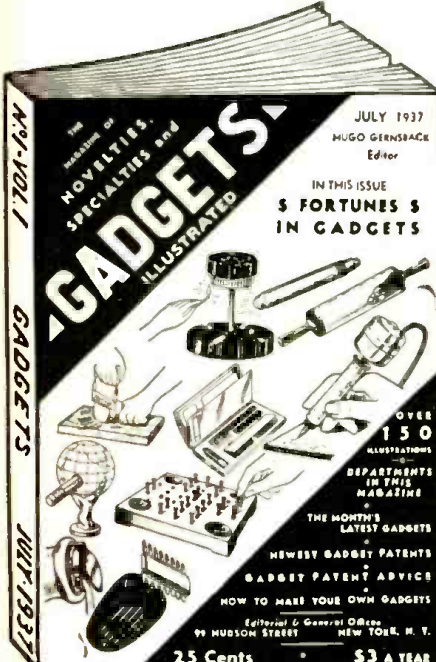

GADGETS

JULY 1937
MUGO GERNSBACK
Editor

IN THIS ISSUE
5 FORTUNES IN GADGETS

OVER 150 ILLUSTRATIONS

DEPARTMENTS IN THIS MAGAZINE

THE MONTH'S LATEST GADGETS

NEWEST GADGET PATENTS

GADGET PATENT ADVICE

HOW TO MAKE YOUR OWN GADGETS

25 Cents • \$3 A YEAR

Editorial & General Office
99 HUDSON STREET
NEW YORK, N. Y.

The world's only magazine on this subject. Contains 150 illustrations of the latest and best gadgets, novelties, and specialties. A veritable gold mine of information which you can not get in any other way.

Every month GADGETS ransacks not only America but the entire world for the newest, most useful articles of this type. Including the latest gadget and novelty patents.

Don't fail to read the article FORTUNES IN GADGETS! Learn how inventors become rich in inventing or devising simple gadgets!

If your newsdealer cannot supply GADGETS MAGAZINE send 25c to

GADGETS Magazine
99-S Hudson Street, New York City

Let's "Listen In" With Joe Miller

(Continued from page 178)

fication, made on or near the half-hour; the station ordinarily rings 2 or 3 dozen chimes in varying sequence. Sked is: Beginning at 4:30, 5, 5:30 or 6 a.m., from which time a Chinese program is presented until 7:30 a.m., following this French recordings are heard till 9:30 a.m., close down. At present the station is using 11.72 mc. where it interferes with CR7BH at 9:30 a.m., and on 5.985 mc. it is in the midst of a mess of code stations.

ALGERIA

The station located at Alger and operating on 12.12 mc. and 8.96 mc. has replied to George Sholin, also in San Francisco, and has informed George that the call letters of their station are as follows: TPZ-12.12 mc. TPZ2-8.96 mc. Thanks, George, that's news! TPZ2 continues to be heard phoning (side-band secrecy) with TYA2, 9.03 mc. Paris, usually between 4:30-6 p.m., and 1-2 a.m. Always a strong signal here.

SOUTH AFRICA

Overseas Communications of South Africa, Ltd., was heard recently by Ashley Walcott testing a new station at Capetown on a freq. of 8900 kc. or 8.90 mc., asking that reports be sent to the Chief Engineer, P. O. Box 962, Capetown. Programs were relayed from the Capetown broadcasting station from 9 to 10:45 a.m., fade out. This time is too late for the Eastern DXers to be able to hear this new station. The company mentioned also operates ZSS and ZSR, Capetown commercial phones.

BELGIAN CONGO

OPM, the commercial phone at Leopoldville, Belgian Congo, has verified to several of our DX friends, including Dave Styles and Ed Goss, and gives the following sked: OPL, 20.04 mc. from 4:30-11:30 a.m., OPM, 10.14 mc., 2-3:30 p.m., these times for phoning Belgium. Right now OPL is the most active and may be heard best between 9:30-11:30 a.m.

CHINA

The Chinese commercials seem to come through despite summer conditions, and with the higher frequency Japanese commercials may be depended on to supply us with some "Asiaties" to hunt for during the summer months.

XTV, 9.495 mc., Canton, is often heard phoning XTR, 9.36 mc., Swatow, best 5:45-6 a.m., both strong signals with the typical Asiatic rapid fading signal.

XOJ, 15.795 mc., Shanghai, has been heard often near 6 a.m. of late, and Ashley Walcott now hears XOJ phoning KWU 15.35 mc., Dixon, daily except Sunday, from 9:30 to 11:30 a.m., with an R9 signal. XOJ replaces XGW. XTB, 11.415 mc., is sometimes used instead of XOJ.

Other Chinese heard are: XTS, 11.47 mc., Swatow—XTU, 12.07 mc., Canton—XTK, 9.08 mc., Hankow.

XTS or XTR phones XTU or XTV and sometimes XTB, from 2-9:30 a.m., almost every day. XTB replaces XTC on all internal telephone service.

XTK is still used to phone XTB and XTV between 4-9:30 a.m.

Have you DXing OMs got all these verified yet? QRA is given in previous issues.

INDIA

"The Government Radio Station," Rangoon, Burma, is still heard on West Coast from 9-9:35 a.m., daily, reports Ashley Walcott. This station changes frequency about every 2 or 3 weeks, and last heard on 6005 kc. (announced). The first half of the program consists of European concert music, the latter half, Burmese music. Rangoon will not be good DX till the arrival of Fall.

ASIATIC REVIEW

ZGB, Kuala Lumpur, Federated Malay States, was logged once at 9 a.m., by Ashley Walcott, concluding a test on an announced frequency of 13.643 mc., after a contact with Bandoeng, Java.

ZHJ, at Penang, Straits Settlements, has been on 6.055 mc. for the last two months.

VPB, Colombo, Ceylon, has changed to approx. 6.115 mc., and is audible on West Coast from 7-9:30 a.m., daily. This rare catch for the East Coast may be heard this coming Fall and Winter. So keep it in mind, all you Eastern DX boys!

HS8PJ, Bangkok, Siam, now has a new sked: Mondays, 8-10 a.m., on 9.35 mc. Saturdays, 1-2:30 p.m., on 9.35 mc. The 19.02 frequency has been discontinued.

A new telephone station at Palembang, Sumatra, on 7.87 mc., phones PLQ, 10.68 mc., Bandoeng, between 5:30-6 a.m., also from 7-8:30 a.m., irregularly. No call known, although of course, it begins with letters YB, the prefix used by Sumatran phones.

CQN, Macao, Portuguese China, has again moved, now from 9.94 mc., to 10.135 mc., and heard in West lately with good volume but poor quality.

TDE, 10.065 mc., Shinkyo, Manchukuo, phones JVO, 10.37 mc., throughout the morning, both last heard with fine signals at 6:20 a.m. If these two are on, and they are on daily, you can "log" them, despite conditions. They are so reliable.

YDB, Soerbaja, Java, is still being well heard on 9.55 mc., where they moved a month ago, from 9.65 mc., and it seems to be a permanent frequency.

JIB, 10.53 mc., Taihoku, Formosa, heard well at 5:55 a.m., phoning.

Bill Harriman of San Pedro, Calif., reports KPM, on an announced frequency of 10.91 mc., testing and calling KWU, Dixon, Calif. KPM is in the Philippines.

ZGE, at Kuala Lumpur, Federated Malay States, has been reported by a West Australian DXer to announce as follows: "This is Kuala Lumpur calling. Station ZGE, on 48.92 meters and 48.10 meters."

This station is reported on the 48.10 meter wave, which corresponds to approximately 6.235 mc., by Ashley Walcott and George Sholin. ZGE does not use both waves simultaneously. Oddly, everyone who hears ZGE on the higher frequency, 6.235 mc., reports ZGE much stronger than on the other wave and believes that their power is increased.

AFRICAN REVIEW

Congrats to Ashley Walcott for his "landing" VQ7LO, 6.085 mc., Nairobi, KENYA COLONY! He heard it "signing off" at 9:20 a.m., with positive identification. We have yet to cross 7LO off our "GET" list.

A letter from M. Wasserzug of 48 Eckstein St., Mountain View, Johannesburg, South Africa, states that station ZUD, at Pretoria, operates irregularly on 60 and 34.5 meters, or 5.00 and 8.695 mc., and that it may soon be in regular operation. Power is 10 kw., and reports should go to G. P. O., Pretoria, South Africa.

Ted Bottema writes to tell us he has verified IUG, 15.45 mc., for 3 a.m. reception.

George Dent of ZS6AM says ZNB, Mafeking, Bechuanaland Protectorate, is on daily 1-2:30 p.m., on 5.90 mc., using a Collins XMTR with 210 watts input and is heard R9 in Johannesburg. Also adds that CR7AA and CR7BH use 1 kw. input.

"VAC"

Mr. Gernsback has promised to have the "VAC" certificate ready for either this or the next issue, so we hope to be able to offer it to you soon. Regarding VAC, it should be made known that we will soon adopt the new standard regarding continental divisions. Both the ARRL, and the IARU, world-wide amateur organizations, are now listing the Philippines, and all of the Netherland East Indies (Java), as parts of Australasia, so that all Javanese veris will now be listed with the Australian stations, no longer as Asiatics.

So, fellow DXers, change your VAC records accordingly, and let us have your revised VAC standing at once! Due now to the greater difficulty of logging and verifying Asiatics, we will begin to list all those with 3 or more VAC, beginning with the next issue. Yes, OMs, we also lose, having to drop 13 VAC with the adoption of this ruling.

Please mention SHORT WAVE & TELEVISION when writing advertisers

★ ★ ★ HAM STARDUST ★ ★ ★

The Africans have been coming in better and Asiatics poorer. Australians are strangely unlike last Spring, when most mornings brought the VKs forth in dozen lots, whereas now, we find them rather scarce, though at least a few may be heard any morning. We feel that by July and August, the VKs will be in full swing, best between 12:30-2 a.m., and 5-6:30 a.m. Please give frequencies and time heard in E.S.T., of every "ham" heard.

AFRICANS

OQ5AA, near 14050, Belgian Congo, seems to lead the handwagon, with an R99 signal here from 4:45 to 5:30 p.m., heard several times.

EA9AH 14010, at Tetuan, Spanish Morocco, was heard with an R9 signal several times near 4:30-5:30 p.m. Announced as "Aqui la estacion ay-ah-nueve-ah-achee. Marruecas Espanol." A prompt veri awaits reports to Apartado 124, Tetuan, Sp. Morocco. This is a "rebel" station.

ZS6AM, George Dent sends a vy FB letter and fotos, but no QSL! Our luck again, very bad, as George sez he's out of QSL's but veris anyway. George really has achieved a distinction for a 21-year-old ham, having WAC on CW and phone, 20 and 40 meters, using 20 watts input!!! George also has WBE on phone and CW. Look for George next Oct. or Nov. around 11:30 p.m., on 20 meters. He'll be there. Have seen his QSL, vy FB. He'll QSL all reports.

Mr. Wasserzug of Johannesburg, S. Africa, sends a list of new So. African 20 meter phones to look for next Fall, mostly between 14,000 and 14,150. They are ZT1M, ZT2L, ZT6A, ZT6T, ZS1B, ZS1AX, ZS3F, ZS6AA, ZS6Q. Tnx, OM.

Tony Holthausen of ZT6N wants DXers to look for him from May to Sept. on 75 meter phone! That would be a catch!

Chris Jaffé of Virginia reports hearing SUIAS, SUIRO, SUIKG, SUICH, and SU4AG. SUI5G has informed us that SUIAS is a pirate, unknown in Egypt. Chris also heard EA9AH and CR7AW, Mozambique on 40 meter phone. And FA8III, Algeria on 75 meter phone. Nice going, Chris!

W. S. Wade of Portland, Oregon, has logged ZS6AJ, ZS6AA, ZU6J, ZS2X, South Africa, VQ2EWA, Northern Rhodesia; CN8MA, Morocco. Also reports just receiving a QSL from EL1A in Liberia, which should quell reports that he is a pirate station. That's news!!

George Sholin, Calif., reports ZS2X, 14040; ZS2N, 14030; ZS2S, 14340; ZT2G, 14255; ZS1AX, 14060 and 14340; ZS1B, 14070; ZS4U, 14140; EL1A, 14290; and a ZS217, 14040. All these heard in recent months. Harry Kentzel, N. Y., reports FT4AA, 14300, 1:20 a.m., also J. O. Faris, Jr., at 12:30 a.m. Clarence Hartzell also received FT4AA at 1:30 a.m.

EA9AH, 7.18 mc., logged working Venezuela at 9:45 p.m. by Manuel Betances, Santurce, Porto Rico. Also EABAS, 7.175 mc., Canary Is., QSOing 9AH same time.

AUSTRALASIANS

Many report KAs in Philippines. PKs in Java, as ASIA, but no more will they count as Asiatics, even though the map shows parts of Java nearer Asia than Australia, etc.

Ashley Walcott reports PK1SK, 14050; PK1JR, Japan-Radio, 14300; PK4VR, Victoria-Radio, 14370, besides the "regulars" given in previous issues. Only new ones here are PK3RW, 14050, and we thought he said VK3RW, until he began "This is the Dutch station." That cleared up things, hi! Also PK6CI, on a new wave, 14265; this catch in the Moluccas Islands, Java.

In the Philippines, Ashley Walcott reports KA1HS, 14080; KA1JR, 14250; KA1MM, 14065; KA1RB has a schedule every other day with KA9WB, Zamboanga, also in Philippines, at 4 a.m.

ASIA

Leading Jap phones are J2KJ, 14260; J2MI, 14270; "Mexico, India," both heard 3-4 a.m., and 9-10 a.m., West Coast.

Chinese phones are XU8HW, 14100, 14230; XU8JR, 14240 and XU8MT.

In Hongkong, we have VS6AB, 14040, 9-10:30 a.m., and VS6AG, America-Germany, 14075, Sundays 9-10 a.m.

Malay States: VS2AK, now on 14260, also 14120. VS2AO, 14200-14270.

In India: VU7FY, VU7KH. Best time to try for above is near 6 a.m., in East.

MISCELLANEOUS "DX"

SP1HH, "Havana-Havana," heard several times, once at 8:45 p.m., and also at 5:30 p.m., on 14100: He is in Poland, R8 to 9 signal.

OZ7KG, Denmark, 14080, "Kilowatt, Germany," heard at 8:34 p.m., R8. Also heard by Russ Ballard at 8:15 p.m., and by Harry Kentzel, 7:45 p.m.

EA2BH, "Baltimore, Honolulu," in Spain broadcasting "war news" from the trenches heard on 14020, signing off at 6:50 p.m., announcing he would be on again at 11:30 GMT next day.

Russ Leader, San Francisco, reports K7-FST 14090 at 1:15 a.m.

Harry Kentzel reports I1KS, Italy, 14290 at 2:15 a.m.; HB9J, Switzerland, 14380; at 3 a.m. SVIKE, 14080-14260, 8-9 p.m.; SM7YA, Sweden, 14030-14070, 2 a.m.; SM5SV, 14326, 8:30 p.m.

Chris Jaffé reports, HA8A, Hungary, on 75 meter phone.

W10XDA, S. S. Morrissey, on the Bartlett Expedition to Greenland, at last QSLd report of last August, and much to our delight was at Greenland at time heard, so at last we have Greenland verified, as NX2Z.

Harold W. Tidman, Auckland, New Zealand, regarding the recent Amateur DX Contest says "outstanding were the lady operators. CE1AH with an R7 consistently, also W21XY and W4AGB, both with nice strength and excellent quality."

The "Steerable" Antenna - How It Works

(Continued from page 169)

good path can be found; the third circuit would be set for it. This circuit is not connected directly to the telephone line, but there is included an adjustable delay circuit through which it takes some time for the signal to pass. When this delay is adjusted correctly, it compensates almost exactly for the fact that the two different signals coming in at different angles have traveled different paths, one longer and one shorter. Adding delay to the shorter path signal makes them of equal length before they are combined in the telephone line.

In an ordinary short-wave receiver with essentially non-directive antenna, all the signal components from different angles come into the receiver circuits together and combine, without their delays being adjusted. This is what causes the severe selective fading and distortion characteristic of simple short-wave receivers on long distance signals. The new system not only obviates this difficulty, but on account of its sharp directivity still further reduces noise as compared with good previous practice.

W. S. Paley Makes First Amateur Award

(Continued from page 177)

dian Department of Marine; the Hon. Anning S. Prall; Dr. J. H. Dellinger, chief of the Radio Section of the U. S. Bureau of Standards; and Professor A. E. Kennelly, professor emeritus of electrical engineering at Harvard University.

The award is to be presented each year to that individual who, in the opinion of an impartial board of awards, has contributed most usefully to the American people and is to be open to all amateur radio operators in the United States and Canada.

YOU BUFFALO AMATEURS
make the
DYMAC RADIO CO.
216 E. Genesee Street

your source
for



"NO BACK TALK"

TRANSFORMERS and ADD-A-UNIT TRANSMITTER KITS

Use a transformer that's really engineered—that does not overheat and that won't feed back. Utah Transformers are electrically and mechanically sound, with uniformly wound coils, ample insulation and careful impregnation. They'll give you better performance and longer life. A complete line is available, write for Catalog for complete specifications.

UTAH ADD-A-UNIT KIT
80 Watt Input
Only **\$49.75**

Build your own powerful transmitter, simply and easily, with the Utah Add-a-Unit Kit, at a fraction of the cost of a factory assembled job, with Utah built and tested parts. Additional Unit Kits available, that plug in to your first one, so that in time you can have a complete 400 Watt phone transmitter. See your local jobber, or write Dept. SW8 for complete information.

UTAH RADIO PRODUCTS CO.
CHICAGO, U. S. A.
TORONTO ONTARIO, CANADA (UCOA RADIO PRODUCTS CO.)
BUENOS AIRES
"16 YEARS OF LEADERSHIP"

SEE PAGE 206 FOR THE 6 BEST BOOKS ON SHORT WAVES

TR-6A6 TRANSMITTER - RECEIVER
FOR 5-METER BAND
DUPLEX OPERATION

A complete 5-Meter Station, including a Receiver and Transmitter for DUPLEX break-in operation. Both units housed in a sturdy black crystalline cabinet, with separate tuning dials and speaker.

AMATEUR PRICE \$39.75 NET LESS TUBES
Also A Crystal Controlled Model

Write for new 1937 catalog

CAMERADIO

963 LIBERTY AVE. PITTSBURGH, PA. ● 30 TWELFTH ST. WHEELING, W. VA.
Established 1919

Please mention SHORT WAVE & TELEVISION when writing advertisers

H. G. CISIN'S All-Wave Air Scout Jr. Radios **THREE-TUBE \$3.20** ALL ELECTRIC ALL WAVE SET MODEL 3A-E

A powerful sensitive all-wave set. Holds wonderful records for foreign reception. Also brings in police calls, amateur, code, transatlantic phone and broadcast entertainment. Excellent volume. Works from any A.C. or D.C. house current. Easiest set to build. Employs newest metal ballast tube. Speaker mounts on attractive panel. Range 915 to 610 meters or to 1500 meters with special long wave coil. Complete kit includes: Earphone, broadcast coil, 70 to 200 meter coil, panel (two styles available, pointed or rectangular top). Chassis, High Grade Variable Condenser, Potentiometer, Antenna Trimmer, Dial, Sockets, Knobs, Wire, Resistors, Condensers, and all other required parts including instructions and diagrams. **Use in ONLY.**

ONE-TUBE BATTERY SET—Model 1B Satisfied owners report MARVELOUS FOREIGN RECEPTION. Also can be used for S.W. and broadcast reception same as model 3A-E. Earphone reception. Complete kit includes parts listed above plus 30 tube and filament rheostat. **Use in ONLY.**
\$3.20 With Tube and batteries.
TWO-TUBE BATTERY SET—Model 2B Complete kit including all parts in the 1-tube model plus parts for extra audio stage including power tube.
\$2.95 With Two Tubes & batteries.
THREE-TUBE DE LUXE BATTERY SET—Model 3B Complete kit including all parts in the 1-tube model plus parts for two extra audio stages including 30-type tubes and 33. **\$3.45** With Three Tubes power output tube.
Following Auxiliary Parts are available: 915 to 610 meter coil 25c; 15 to 45 meter coil (foreign) 25c; 40 to 80 meter coil (foreign) 25c; 22.5 volt "B" battery 75c; Two flashlight "A" batteries 10c each; 3" Find-All Loud Speaker \$1; Complete Antenna Kit 50c; Wood Screw Kit 10c. Tubes for Model 3A-E, each 45c. Long Wave Unit and coil for any model \$1. Double Earphones \$1.30. Any model with extra 75c.
NOTE: If you already have earphones, two extra foreign coils may be substituted in any model.
H. G. CISIN, Chief Eng., ALLIED ENG. INSTITUTE
98 Park Place Dept S-38 New York, N. Y.

Short Wave Scouts

(Continued from page 176)

- Europe
- CT2AJ, 4000 kc., Ponta Delgada, Azores. English calls and programs.
 - EJ4J3, 28-90 mtrs., Radio Club Tenerife, Canary Isles.
 - CT1AA, 9650 kc., Estacao Radio CT1AA, Radio Colonial, Lisbon, Portugal.
 - EAQ, 9860 kc., La Voz de Espana, P. O. Box 951, Madrid, Spain.
 - ORK, 10330 kc., Radio Ruysselede, West Flanders, Belgium.
 - TPA2, 15245 kc., Radio Coloniale, Paris, France.
 - TPA3, 11980 kc., Radio Coloniale, Paris, France.
 - TPA4, 11715 kc., Radio Coloniale, Paris, France.
 - PHI, 11730 kc., Hilversum, Holland.
 - HVJ, 15120 kc., Radio Vatican, Vatican.
 - HBP, 7797 kc., Radionations, League of Nations, Geneva, Switzerland.
 - TFJ, 12235 kc., Reykjavik, Iceland.
 - RNE, 12000 kc., Radio Centre, Moscow, U.S.S.R.
 - RAN, 9600 kc., Radio Centre, Moscow, U.S.S.R.
 - 2RO3, 9635 kc., Rome Short Wave Radio Station 2RO, Rome, Italy.
 - 2RO4, 11810 kc., Rome Short Wave Radio Station 2RO, Rome, Italy.
 - IAC, 17699 kc., Centro Di Coltano Radio, Pisa, Italy.
 - HAS3, 15370 kc., Radiolabor, Budapest, Hungary.
 - HAT4, 9125 kc., Radiolabor, Budapest, Hungary.
 - DJA 9560 kc.
 - DJC 6020 kc.
 - DJD 11770 kc.
 - DJN 9540 kc.
 - DJO 11795 kc.
 - DJR 15340 kc.
 - DJG 15360 kc.
 - DAP 17265 kc., Norddeich, Germany.
- Asia
- JVN, 10660 kc., Tokyo, Japan.
 - JZI, 9535 kc., Broadcasting Corporation of Japan, Tokyo, Japan.
 - FO8AA, 7100 kc., Radio Club Oceanic, Papeete, Tahiti.

Accessories for Members of the SHORT WAVE LEAGUE

Every member of the SHORT WAVE LEAGUE wants to identify himself in some way. For your convenience the League directors have prepared suitable letterheads, lapel buttons, stickers, etc. In addition there are many short-wave accessories, such as maps, globes, etc., which the League offers only to members at special prices. Take your choice from this advertisement. THESE ESSENTIALS ARE SOLD ONLY TO LEAGUE MEMBERS.

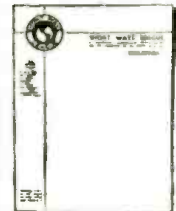

LEAGUE LETTERHEADS
A beautiful, official letterhead has been designed for members' correspondence. The letterhead is invaluable when it becomes necessary to deal with the radio industry, mail order houses and radio manufacturers, as many houses offer members of the LEAGUE preferential discount. The letterhead is also absolutely essential when writing for verification to radio stations either here or abroad. It automatically gives you a professional standing.

A—SHORT WAVE LEAGUE letterheads. **50c** per 100

A—50c per 100

WORLD GLOBE

This important essential is an ornament for every den or study. It is a globe, 6 in. in diameter, printed in fifteen colors, glazed in such a way that it can be washed. This globe helps you to intelligently locate foreign stations. The base is of solid walnut, and the semi-meridian of a nickel-like metal. Entire device substantially made, and will give an attractive appearance to every station, emphasizing the importance of the work of the operator.



D—Globe of the World **89c** Prepaid

D—89c each

SHORT WAVE MAP OF THE WORLD

This beautiful map, measuring 18x26 in. and printed in 18 colors is indispensable when hung in sight or pinned "under the glass" on the table or wall of the short wave enthusiast. It contains a wealth of information such as distances to all parts of the world, political nature of the country in which a broadcast station is located, etc., and from the manner in which the map is block-off gives the time in different parts of the world at a glance.



F—SHORT WAVE Map of the World. **25c** Prepaid

WORLD RADIO MAP AND STATION FINDER

The finest device of its kind published. The world's map on heavy board is divided into 33 sections, while the rotary disc shows you immediately the exact time in any foreign country. Invaluable in logging foreign stations. Also gives call letters assigned to all nations. Size 11"x22".

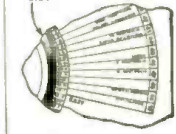

G—Radio Map of the World and Station Finder. **25c** Prepaid

LEAGUE LAPEL BUTTON



E—35c each

This beautiful button is made in hard enamel in four colors, red, white, blue and gold. It measures three quarters of an inch in diameter. By wearing this button, other members will recognize you and it will give you a professional air. Made in bronze, gold filled, not plated. Must be seen to be appreciated.

E—SHORT WAVE LEAGUE lapel button **35c** Prepaid

EE—SHORT WAVE LEAGUE lapel button, like the one described above but in solid gold. **\$2.00** Prepaid

SHORT WAVE LEAGUE
99-101 Hudson St., New York, N. Y.

LEAGUE SEALS



G—15c for 25
These seals or stickers are executed in three colors and measure 1 1/4 in. in diameter, and are gummed on one side. They are used by members to mark stationery, letterheads, envelopes, postal cards and the like. The seal signifies that you are a member of the SHORT WAVE LEAGUE. Sold in 25 lots or multiples only.

SHORT WAVE LEAGUE seals, per 25. **15c** Prepaid

SHORT WAVE LEAGUE

99-101 Hudson Street, New York, N. Y.

I am a member in the SHORT WAVE LEAGUE. Please send me application for membership in the SHORT WAVE LEAGUE.

Please send me the following short wave essentials as listed in this advertisement:

for which I enclose \$..... herewith.
Name _____
Address _____
City and State _____
Country _____
(The LEAGUE accepts money order, cash or new U. S. Stamps in any denomination. Register cash and stamps.)

DATAPRINTS!

20 ELECTRIC LODGE & PARTY TRICKS. Fun Galore!
"How to Do 'Em" Data 50c

RADIO CONTROL for MODEL BOATS, etc. Circuit data.....50c
More DATAPRINTS You Need!
50c each Prepaid.....Any 3 prints for \$1.00

- 100 Mechanical Movements
 - Water Turbines
 - Water Wheels
 - Motor Circuits (20)
 - Telephone Hook-ups (20)
 - Polarized Relay, Ultra-sensitive
 - Shocking coil
 - 20 Simple Bell Hook-ups
 - Electric Chime Ring fits any clock
 - Induction Balance (Telautograph)
 - Einhoven String Galvanometer
 - Electric Fan Motor
 - Induction PIPE & ORE LOCATOR
 - Construction Data.....50c
- The **DATAPRINT Co.**
Lock Box 322 RAMSEY, N. J.

MICROPHONE and RECEIVER

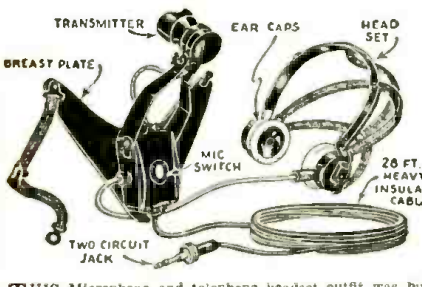

THIS Microphone and telephone headset outfit was built especially for the U. S. Navy Aviation Corps. The Holtzer-Casot Electric Company constructed the outfit to Government specifications. It consists of a low-impedance carbon microphone (transmitter), fastened to a metal breast-plate, and a set of heavy-duty, low-impedance earphones. A switch on the back of the breastplate controls the microphone circuit. The earphones are U. S. N. Utah type, attached to adjustable headband. Twenty-eight feet of heavy weather and waterproof conductor cable furnished. **\$4.96** Current of not more than 10 volts should be used. The shipping weight is 9 lbs.

We will forward Shipments by Express Collect if sufficient postage is not included.

WELLWORTH TRADING CO.
560 W. Washington Blvd., Dept. SWT-837, Chicago, Ill.

Notice To Trophy Contestants

The closing date for the Asia contest announced in the May issue, has been advanced from June 25th to August 25th, in order to provide sufficient time for the veris to reach the contestants from Asiatic stations. Note: We are also including in the Asia group, short-wave stations in the Philippines and the East Indies. The group for which entries must be in the Editor's hands by September 25th are Australia, Africa and Oceania. The group in which entries must be in our hands by October 25th, includes the veris from European short-wave stations, including Iceland. For entries to be in the Editor's hands by November 25th, North America (including Central America, West Indies, Canada and Mexico) veris are to be in by that time. For entries to be in our hands by December 24th, South American stations are the objective.

Please mention SHORT WAVE & TELEVISION when writing advertisers

The 5-40-400 Transmitter

(Continued from page 175)

is provided by using a pair of National No. 12 Grid Grips which just fit the rods. One end of these has been flattened out and a hole has been drilled so that a nut and bolt can be used in connection with the Mica condensers, which are employed to keep the D.C. out of the antenna circuit. By arranging the binding posts at the other extremity of the condensers in such a way that the tops of the posts come together at the center, short-circuits in the transmission line, where it joins the plate rods, are eliminated and the bakelite cases of the condensers themselves form very satisfactory handles for sliding the clips up and down. This should never be attempted when the power is on. Flexibility and high insulation in the lead from the high voltage power-supply to the plate-shortening-bar is provided by using the two conductors in a short piece of Giant-Killer Cable in parallel. Similarly, Giant-Killer Cable has been used for feeding the antenna, as shown in the various illustrations.

Tuning the Transmitter

The procedure for tuning this transmitter, except for the final stage, is identical to the tuning of any other standard arrangement and resonance in the final stage is found by the simple expedient of disconnecting the antenna and running the plate-shortening-bar up and down the plate rods until minimum plate current is indicated, with the right-hand plug inserted in the jack at the extreme right of the front chassis. This operation should be performed by turning off the plate power when adjustments are made. Never lose sight of the fact that we are dealing with sufficient power to kill! Our first mistake will be our last. The frequency at which our own transmitter is operating is approximately 58 megacycles, and the coupling between the plate-shortening-bar and the two connections for the antenna shown are correct for the low-impedance transmission line that we are using.

The selection of a suitable antenna for operation on five meters is a subject which may well be considered in a separate article, and for the time being we might consider it sufficient to say that very satisfactory results have been obtained by the use of a simple antenna, comprising two half-waves in phase with a quarter-wave matching section. The mechanical details of this antenna are worth mentioning because the antenna itself is so simple and so easy to erect that others may desire to duplicate it. Furthermore, it is an unobtrusive affair and is very unlikely to cause any uprisings with apartment house superintendents or any of the village officials even in communities where restrictions are rather severe. Full details for this antenna are shown in one of the diagrams.

The Parts List

- IRC**
 R-1—100,000 ohms, 1 watt
 R-2—15,000 ohms, 10 watts.
 R-3—5,000 ohms, 10 watts.
 R-4—100,000 ohms, 1 watt.
 R-5—250 ohms, 2 watts.
 R-6—5,000 ohms, 10 watts.
 R-7—10,000 ohms, 75 watts.
 R-8—5,000 ohms, 50 watts.

- TRANSFORMERS**
 T-1—Filament Transformers—
 T-2—Filament Transformers—
 T-3—Filament Transformers—

- CORNELL-DUBILIER**
 C-1—.01 mf., 400 volts.
 C-2—.01 mf., 400 volts.
 C-3—.01 mf., 400 volts.

C-4 (Represents the two variable condensers—supplied with the National FXTB units connected in parallel.)

- C-5—.001, 500 volts Mica.
 C-6, C-7, C-8 and C-9—.01, 600 volts.

C-10—(One of the two condensers supplied with the National FXTB Unit—the other condensers supplied with this unit are not used in this particular assembly.)

- C-11—.00005 mf. 500 volt Mica
 C-12 and 13—.002 mf. 1000 volt Mica.
 C-14—.002 mf. 2000 volt Mica.
 C-18 and 19—.002 mf. 1000 volt Mica.
 C-20 and 21—.002 mf. 2500 volt Mica.

- C-22—.002 mf. 5000 volt Mica.
 C-23—.01 mf. 400 volt Mica.
NATIONAL
 C-15—National Type TMC-100-D Variable Condenser.
 C-16 and 17—National Type NC-800 Neutralizing Condensers.

Sockets and Insulators

- 3—5 prong Isolantite Receiving Sockets
 2—Octal Sockets
 3—Type XM-10 sockets
 3—Type SX-1 Feed-Through Insulators
 5—Type GS-1 Stand-off Insulators
 4—Type GS3 stand-off insulators
 RFC—1, 2, 3, 4 and 5 are National Type R-100 chokes (2.5 mh.)
 1—National type "0" Dials.

TUBES—RAYTHEON

- 616—Oscillator
 616—Doublers
 RK-37—Doublers
 RK-38—Push-pull in the final stage.
 J-1, J-2, J-3, J-4 and J-5 and single closed-circuit jacks.

COIL DATA

L-1 is made of 11 turns of No. 22 Enameled Copper Wire bound into a coil one inch long on the RK-39 coil form supplied with the National FXTB Fixed Tuned Exciter Tank Assemblies.

L-2 is made of five turns of No. 22 Enameled Wire wound into a coil $\frac{3}{8}$ " long on the RK-39 coil form supplied with the National FXTB Fixed Tuned Exciter Tank Assemblies.

L-3 is made of four turns of No. 12 Enameled Copper Wire, wound into $1\frac{1}{4}$ " diameter with $\frac{3}{8}$ " spacing between the turns and center tapped as shown in figure.

L-4 is made up of four turns of No. 12 Enameled Copper wire $\frac{7}{8}$ " in diameter and spaced a quarter of an inch between turns.

L-3 and L-4 are mounted on a National type PB-5 plug, which in turn is mounted on a National type XB-5 socket.

L-4 it will be observed is centered inside the winding L-3.

L-5 represents the rods in the plate circuit and their dimensions are given in figure.

(Ten meter rods are made in an entirely different form and they will be fully described in a future article.)

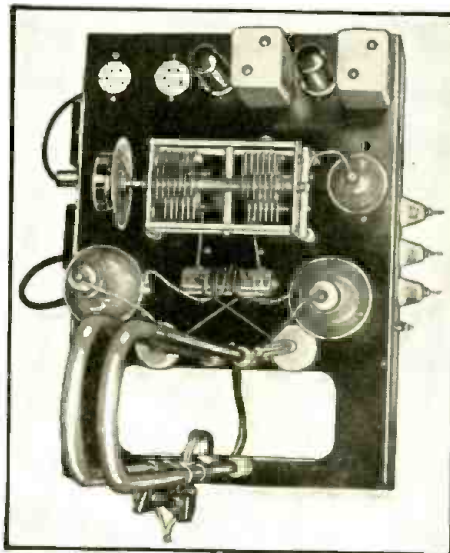

Top View of R.F. Unit.

"CQ"

● W3GGM called CQ on 20 meters and was answered by W8IWS. He mentioned this was his first W8 QSO on 20. 8IWS came back and said he was on ten meters and was copying 3GGM on ten!—Ted Supplee, W3GGM.

Several foreign "Hams" with whom I have been exchanging stamps have asked me to turn "Ham" stamp exchange. Our QSO's are something more substantial than RST & W reports. Will be glad to hear from any stamp collecting "Ham."—W7GEQ.

Here's a CQ for you. My regeneration set is like a train—it whistles for every station!—Russell Sommerlot.

Please mention SHORT WAVE & TELEVISION when writing advertisers



*"A GRAND RECEIVER"

"SAYS William Greer, chief engineer of WNEU. He adds, "Super-Pro" . . . only set able to use for re-broadcasting . . . "Super-Pro" not susceptible to the high noise level . . . Found possible to receive United States stations with a field intensity of a few micro-volts, and frequency separated from WNEU's by only a few kilocycles."

MAIL COUPON FOR DETAILS!

HAMMARLUND MFG. CO., Inc.
 424-438 W. 33rd St., N. Y. City

Please Mail me new "Super-Pro" bulletin.

Name

Address

City State



HAMMARLUND

Two Way Communication

Inter-phones, office to office, factory, shipping depts., house to garage and hundreds of other uses. Positive in operation. Simple to install. Modern in appearance. Any number of phones on same line. Dealers and jobbers write for discounts.

Microphone Division
UNIVERSAL MICROPHONE CO. LTD.
 Box 299 Inglewood, Calif., U. S. A.

GOOD RESULTS Demand GOOD INSTRUMENTS



Model 326
 D. C. Milliammeter

TRIPLETT manufactures a complete line of measuring instruments for radio, electrical and general industrial purposes both standard and custom built . . . For better short-wave work, write for catalogue.

Triplet Electrical Instrument Co.
 288 Harmon Ave.
 Bluffton, Ohio



On broadcast as well as shortwave frequencies, in any location, you can eliminate "man-made" static with

NOISE-MASTER

ALL-WAVE ANTENNA

Send for complete literature.
 CORMISH WIRE CO., 39 CHURCH STREET, NEW YORK CITY



BRINGS YOU ANY ONE OF THESE 4 FAMOUS RADIO BOOKS

RADIO FANS! Help yourselves to a radio education for the price of 10c per book. These books give you a good foundation towards the study of radio. You'll be amazed at the wealth of information contained in them. They are especially written for beginners but are useful review and reference books for all.

Each book contains 32 pages, profusely illustrated with clear, self-explanatory diagrams. They contain over 15,000 words of clear legible type. They are an education in themselves and lay the groundwork for a complete study of radio and electricity.

HOW TO BUILD FOUR DOERLE SHORT-WAVE SETS

Due to a special arrangement with the publishers of SHORT WAVE CRAFT, we present in this book complete details for building the Doerle sets, also an excellent power pack if you plan to electrify any of the sets. Contains EVERYTHING that has ever been printed on these famous receivers. These are the famous sets that appeared in SHORT WAVE CRAFT: "A 2-Tube Receiver that Reaches the 12,500 Mile Mark," by Walter C. Doerle, "A 3-Tube 'Signal Gripper,'" by Walter C. Doerle, "The Doerle

HOW TO MAKE THE MOST POPULAR ALL-WAVE 1- AND 2-TUBE RECEIVERS

This book contains a number of excellent 1- and 2-tube sets, some of which have appeared in past issues of RADIO-CRAFT. These sets are not toys, but have been carefully engineered. They are not expensive, but mention only a few of the sets the following will give you an idea. The Megadyne 1-Tube Pentode Loudspeaker Set, by Hugo Gernsback—Electrifying The Megadyne—How to Make a 1-Tube Loudspeaker Set, by W. P. Cheney—How to Make a Simple 1-Tube All-Wave Electric Set, by F. W. Haris—How To Build A Four-in-Two All-Wave Electric Set, by J. T. Bernsey, and others. Each set is fully described in simple language so that anyone can build with limited means and with practically no experience a worthwhile all-wave radio set. Has 30 illustrations. 10c postpaid

ALTERNATING CURRENT FOR BEGINNERS

This book gives the beginner a foothold in electricity and radio. Electric circuits are explained. This includes Ohm's Law, alternating current, sine waves, volts, amperes, watts, condensers, transformers, motors and generators, A.C. instruments, house-wiring systems, electrical appliances and electric lamps. Here are some of the practical experiments which you can perform. Simple tests for differentiating between A.C. and D.C.; how to light a lamp by induction; making a simple electric horn; demagnetizing a watch; testing motor armatures; charging storage batteries from A.C. outlet; testing condensers with A.C.; making A.C. electromagnets; trying eggs on a cake of iron; making simple A.C. motors and many others. Has 42 illustrations. 10c postpaid

ALL ABOUT AERIALS

In simple, understandable language this book explains the theory underlying the various types of aerials: the inverted "L," the Doublet, the Double Doublet, etc. It explains how noise-free reception can be obtained, how low-impedance transmission lines work; why transposed lead-ins are used. It gives in detail the construction of aerials suitable for long-wave broadcast receivers, for

A Real De Luxe "Ham" Station

(Continued from page 168)

ferent power, and, within certain limitations, the plug-in coils allow the use of any transmitter on several bands. From left to right, facing the racks, the first rack contains the low-powered, ten meter transmitter. The final stage is in the top unit with the monitor and frequency meter in the next. The oscillator, doubler and amplifier are on the next level. The protective cover houses twenty of the flat-type telephone relays, which are used for remote control switching, for the telephone switch-board and for the transmitters.

This medium-power ten meter transmitter utilizes a 6L6 crystal oscillator operating with regeneration doubling in the plate circuit from a forty meter crystal to twenty meters. A single 807 is used for doubler to ten, driving a single 35T as an amplifier. The final amplifier is a pair of 35T's in push-pull. This transmitter is modulated by a pair of 35T's in Class B.

The next rack, or second from the readers left, contains the 2 1/2 meter transmitter together with four overlapping ultra-high frequency receivers. The four receivers have, together, continuous band-spread from two to eleven meters.

The third rack, besides containing the telephone switchboard, also mounts a "stand-by" receiver and several speech and bridging amplifiers associated with the switchboard.

The next three racks to the right, including the 24" rack in the center, contain the large transmitter which is used on all bands from 160 to 5 meters. All equipment with the exception of one receiver and one speech-amplifier was entirely designed and constructed by the owner.

The fourth rack contains the 6L6 crystal oscillator, 807 buffer or doubler, 35T first amplifier, and a pair of 50T's in the second amplifier, together with their power supplies and protective equipment. The bias supplies for these stages can also be found in this rack. Each stage is metered in its plate circuit and grid circuit when necessary. All filament supplies are metered. Just above the housing on the fourth rack is the "Variac" voltage control panel.

The center rack holds a pair of 500T's in the final class C plate modulated amplifier. The two meters in the top panel are the antenna meters. The grid tank for this stage is located below the strip of five meters with the power supply at the bottom. The sixth rack holds the modulators which, as can be seen behind the plate glass window, are four Eimac 150T's in push-pull parallel class AB.

The seventh rack, or third from the right, contains speech, and control equipment. The large second panel is the rather new Western Electric 10A high-fidelity broadcast receiver.

The next rack, or second from the right hand end, houses a complete 75 and 160 meter transmitter. This transmitter uses a pair of 10's in push-pull in the final, driven by a 10 buffer and a 47 crystal oscillator. The final is modulated by a pair of 10's in Class B audio.

The relay rack on the far right contains the complete five-meter transmitter. This transmitter uses three 50T's, one as t.p.t.g. oscillator and the remaining pair as a push-pull amplifier. The input to this amplifier is 300 watts and this stage works at quite high efficiency.

All transmitters are controlled from the operating desk, which is located out four feet from the center rack but was moved aside for the photographer. The receivers, oscilloscope and control equipment are located on the desk.

W6TH was awarded the first W.A.C. on 20 meter 'phone in the Sixth District and the 6th certificate in the country. In addition the station holds the first W.A.S. certificate on 'phone and has a W.B.E. certificate.

A well informed radio amateur must include Short Wave & Television on his mailing list as all the articles are up-to-date and very timely, especially those regarding the ultra high frequencies.

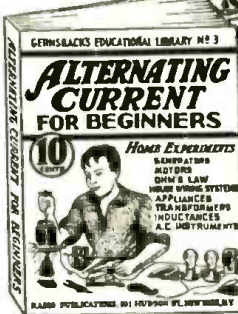
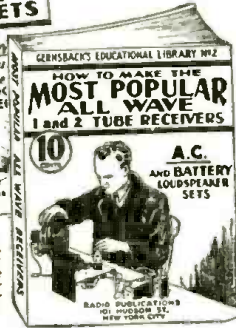
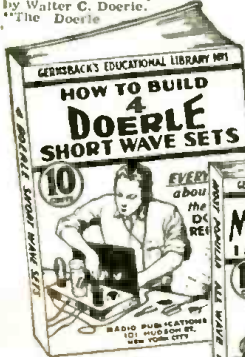

RADIO PUBLICATIONS
101 Hudson Street, New York, N. Y. SWT-837

Please send immediately POSTPAID the books checked:

No. 1—How to Build 4 Doerle Short Wave Sets.....10c
 No. 2—How to Make the Most Popular All-Wave 1- and 2-Tube Receivers.....10c
 No. 3—Alternating Current for Beginners.....10c
 No. 4—All About Aerials.....10c

I am enclosing.....c; the price of each book is 10c
 Send me FREE circular listing 48 new 10c publications

Name

Address

City State

(U. S. Coin or U. S. Stamps acceptable.) Books are sent postpaid.

Remember that each book has 32 pages and contains over 15,000 words. Each book has from 30 to 66 fine illustrations. POSITIVELY THE GREATEST 10c VALUE IN RADIO BOOKS EVER OFFERED TO THE PUBLIC.

If you do not think that these books are worth the money asked for them, return them within 24 hours and your money will be instantly refunded.

Send for our FREE circular listing 48 new 10c Publications

RADIO PUBLICATIONS
101 Hudson St., New York, N. Y.

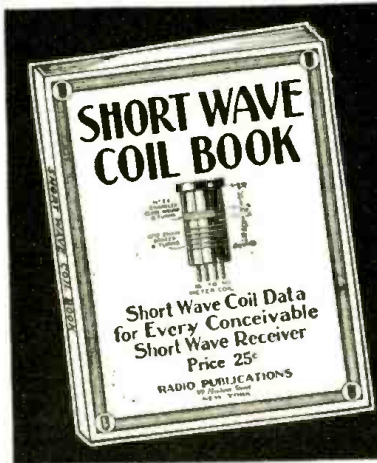

Over 35,000 Set Builders Use This SHORT WAVE COIL BOOK

Every experimenter who has ever tried to build a short wave set knows only too well by experience, that the difference between a good and a poor receiver is usually found in the short wave coils. Very often you have to hunt through copies of magazines, books, etc., to find the information you require about coil winding. Between the two covers of this book you now find every possible bit of information on coil winding that has appeared in print during the past two years. Illustrations show, giving full instructions how to wind coils, dimensions, sizes of wire, curves, how to plot them, by means of which any coil for any particular short wave set can be figured in advance, as to number of turns, size of wire, spacing, etc. There has never been such data published in such easy accessible form as this.

PRICE 25c PREPAID
For a copy of this handy book, send 25c U. S. coin or unused U. S. Postage Stamps to
RADIO PUBLICATIONS
87 HUDSON STREET NEW YORK, N. Y.

Please mention SHORT WAVE & TELEVISION when writing advertisers

Getting Best Results from Your Set

(Continued from page 167)

maximum activity or reception range for a doublet aerial, is at right-angles to the arms of the doublet as shown in Fig. 2. This is important where the maximum receiving range is desired. Some listeners experience difficulty in poor selectivity and here, providing the receiver has a fairly large number of tubes and satisfactory amplification, the length of the aerial may be reduced, and in fact stations several thousands of miles away can be picked up on an aerial but a few feet in length, on a good receiver of the modern super-het type. First, the experiment may be tried of connecting a small fixed condenser of about .001 mf. in series with the aerial, where it connects onto the antenna post on the set. Some prefer to connect a small variable condenser of about 30 to 50 mmf. in series with the antenna, so that the degree of selectivity may be changed. If interfering stations still bother you after cutting down the length of the antenna, try disconnecting the ground connection. This will sharpen up the selectivity considerably.

Eliminating "Code" Interference

In some locations trouble is experienced with code interference. One of the remedies for this is to connect a filter or trap circuit in series with the receiving set as shown in Fig. 3, and several different makes of these code eliminator receivers are available on the market. They usually consisted of an I.F. transformer of about 465 kc. rating arranged as a wave trap.

Pre-Amplifiers to Boost "Weak" Signals

Diagram Fig. 4, shows the principle of connecting a pre-amplifier. The pre-amplifier picks up the weak signals from the antenna circuit and amplifies or strength-

ens them before they are fed into the receiving set proper, where they are rectified.

To Hear 5 and 10 Meter "Sigs"

The real DX "Fan" will therefore be interested in the 10 meter band, and a simple way to hear the stations on this region is to connect a 10 meter converter ahead of the ordinary S-W receiver which does not tune this low. A very good 10-meter converter is described, with photographs and diagrams for its construction, in the May, 1936, issue, page 12. A 5-meter converter was described at length, with full working details, in the October, 1936, issue, page 339. Connection is same as Fig. 4.

Headphones—How to Connect

The short-wave listener frequently desires to operate head-phones from a loud-speaker set, and one method of doing this is shown in the diagram Fig. 5. The phones (or phone jack) are connected in series with a 0.1 mf. condenser (600 volts, v. v.), across from plate to B minus. A switch "S" in the secondary of the output transformer is used to open the loud-speaker circuit when the phones are used. The phones can also be connected in series with the 0.1 mf. condenser, across from plate to B—in the first audio stage.

One of the latest antennas used by a leading short-wave listener, who counts practically the whole world as his own, is the Rhombic antenna. This aerial was described with dimensions and also its characteristics in the Oct.-Nov. issue of *Short Wave Listener*; a very valuable article describing different types of aerials, including the inverted "V" or "half-Rhombic" appeared in the October, 1934, issue of *Short Wave Craft*, with data for constructing it.

A New Television System

(Continued from page 169)

components, e.g., of 24 and 7200 cycles, are generated by the disks and photo-cells of 7a and one part of 8a, which, in principle, is a mechanic-electrical method of generating interlocked saw-tooth impulses. These generated voltages having a saw-tooth wave shape are applied to the deflecting plate-pairs 7 and 8 of the cathode ray tube for the purpose of sweeping the cathode beam 12 back and forth and up and down. Since the disks are driven by a common shaft the voltages are interlocked in such a way that it is impossible for them to get out of phase.

The second rotating disk of 8a and its photo-cell arrangement is used for the purpose of providing secret transmission, if such feature is desired. This disk may have any design of transparency (see for instance, the shaded portions of the disk in Fig. 2) such that its output will be of any pre-arranged frequency, shape and amplitude. The output of this "chopper" disk will be superposed, as indicated in Fig. 1, upon one of the scanning components, suitably amplified with it (through 8b) and introduced to one pair of deflecting plates (8) while the other component (7a) after amplification (7b) has been introduced to the other pair of deflecting plates, 7.

The cathode beam 12, originating at filament 5, passing through anode 6 and being simultaneously deflected by 7 and 8 will, when it reaches the coated emissive surface 3, scan the entire image of the subject or object which is being constantly focused upon surface 3 by the lens arrangement 1 and the mirrors 2a and 2b. The output picture signals appearing across 11, therefore, will be at any given instant, proportional to the lights and shadows of that portion of the image which is being scanned at a given time. At the same time the incoming and amplified signals from the other station, which reach the front separated portion of the tube through 15, will cause ionization emissions between 9a and 9b. These emissions are proportional to the input at any given instant and occur at that place of the tube's cross-section which happens

to be stimulated by the cathode beam 12. The thin wall 4 which separates the narrow front receiving portion of the tube from its rear sending portion is so constructed that the light beams focused on surface 3 do not blur the view of the received image.

The simultaneous scanning of output and input images by a single cathode beam 12 is made possible by a special light sensitive surface 3 and the construction of wall 4, which dissipates (by dispersion) the slantily arriving light rays being focused on surface 3. Also the tube is used in such manner that the cathode beam 12 and its Lendar-Ray extension serve as conductive paths to complete circuits within the tube, the beam itself being assisted to penetrate through the grid-like contractions of 3 and 9. Thus the one cathode-beam 12 not only scans the sending surface 3, but also scans the cross-section of the front receiving portion of the tube, causing spot-like ionizations in the proper scanning sequence wherever it happens to be and in proportion to the signal energies received between 9, 9a and 9b from 15 through 15b and 15a.

Depending upon the design of the "chopper" or "scrambling" disc (Fig. 2), scanning in one of the two directions will take place in an irregular way, in forward and backward jumps, this "irregularity" being governed by the scrambler design. By this device the reception of the image at the other station will be possible only if the receiving station is equipped with an identical scrambling device.

A "2-way" telephone-television is sketched in Fig. 3, three stations of the system being shown with a single, centrally located scanning and synchronizing frequency-generat-

The California Television Society, an experimenting group formed by the author's university and the advanced Television Class at Manual Arts Evening High School are keenly interested in carrying out extensive experiments, as far as means will permit, with this new type cathode ray tube.

The preceding article, the results of explanations by the author and notes taken from the original manuscript, was written by John A. Adams, member of the Radio-Television Technical Staff, National Schools, Los Angeles, California.

COMPLETE

STANCOR KIT



- 4 OSCILLATORS
- Straight Pentode
- Tritet
- Jones
- Bi-Push
- 2 BUFFER DOUBLERS
- Triode
- Dual Triode
- 4 AMPLIFIERS
- Single Triode (T20 or Type 10)
- Push-Pull Triode (T20 or Type 10)
- Single Pentode (RK-39 etc.)
- Push-Pull Pentode (Bi-Push) Forty-Eight Combinations

48 CIRCUIT
COMBINATIONS

FOR \$49⁹⁵

Here's a natural for the medium-power amateur. 4 Oscillators . . . 2 Buffer-Doublers . . . and 4 Amplifiers . . . \$5 to 120 watts input . . . ALL FROM A SINGLE KIT. The kit includes circuits on the most recently released tubes . . . and circuits on older types of tubes that you probably have in your shack. The new Stancor "48-C" Kit contains all the parts you need FOR EVERY CIRCUIT — less crystal, tubes and meter.

COMPLETE SCHEMATIC BLUE PRINTS FREE WITH EVERY KIT

STANDARD TRANSFORMER CORPORATION

850 BLACKHAWK STREET • CHICAGO

WORLD WIDE
ALL WAVE ~ RADIO

SPECIAL!!

For a Limited
Time Longer!



The sensational "Ace Dace" Two Tube receiver for only \$2.25! Thousands sold at regular \$3.00 price. THIS MONTH ONLY—for \$2.25 we send you, postpaid, the complete kit containing an attractive metal chassis, panel, and every part needed to build this powerful all electric short and long wave receiver, unwired, less tubes and phones. No batteries needed! Just plug into any house current socket. AMAZING VALUE! Can actually bring in foreign stations from all parts of the world, police calls, airplanes, amateurs, etc., as well as your local stations! Ace radios give GUARANTEED RESULTS! Our clear diagrams make it simple to hook-up. Free Circuit.

ONE TUBE Battery operated receiver. Complete kit of parts, unwired, less tube, batteries, and phones. \$1.25

TWO TUBE Battery receiver. For most excellent beginner's receiver! Complete kit—unwired. \$2.00

Any kit laboratory wired and tested 75c extra. First Grade tubes—75c each. Double headphones—\$1.15. REMEMBER! We pay the postage. Saves you up to 50c. ENJOY NEW THRILLS!! SEND FOR YOUR ACE RADIO TODAY!

ACE RADIO LABORATORIES

70 Barclay St. Dept. C-8 New York City

MILADY

The Woman Magazine Sensation

MILADY (combined with WDMAN'S DIGEST) is the magazine of by and about women—it brings you inside facts on many popular subjects. There's tips on fashions, beauty secrets, child problems, recipes and the home. Monthly cash prizes too. There are sparkling short stories and best reviews from the world's press. MILADY has a beautiful three-color cover and complete 9x9 1/2" full-page illustrations. For your mother, your sister, sweetheart or wife. On all good newsstands at 25c a copy, or Send \$1.00 to publishers for the next five months' issues. New York, N.Y.

MILADY, 99-5W Hudson St., New York, N.Y.

COMPLETE ELECTRIC PLANTS



ONAN ALTERNATING CURRENT PLANTS furnish same as city current anywhere. Operate on gasoline. Run Radio, Water System, Refrigerator, all Appliances. Complete, ready to run. **SIZES 350 WATTS UP**

Easy to install. Available from stock. For Farms, Camps, Commercial use. Sizes for any purpose. Write for details. D. W. ONAN & SONS

558 Royalston Ave. Minneapolis, Minn

Please mention SHORT WAVE & TELEVISION when writing advertisers

SHORT-WAVE BOOKS with a WORLD-WIDE REPUTATION!

101 SHORT-WAVE HOOK-UPS
 Here is a worthwhile book that every short-wave listener, every short-wave fan, and every amateur needs. It gives you the 101 best short-wave hook-ups which have appeared heretofore.
 100 Illustrations
50c



HOW TO GET THE BEST SHORT-WAVE RECEPTION
 This book tells you everything you have ever wanted to know about short-wave reception. The author, a professional radio listener and radio fan for many years, gives you his long-experiences in radio.
 40 Illustrations
50c



THE SHORT-WAVE BEGINNER'S BOOK
 Here is a book that solves your short wave problems—leading you in easy stages from the simplest fundamentals to the present stage of the most advanced known long-wave and short-wave for the beginner.
 40 Pages
25c



TEN MOST POPULAR SHORT-WAVE RECEIVERS
 —HOW TO MAKE AND WORK THEM
 The editors of SHORT WAVE AND TELEVISION describe, each receiver is fully illustrated with a complete layout, pictorial representation, photographs of the set complete, hook-up and all worth-while specifications.
 75 Illustrations, 40 Pages
25c

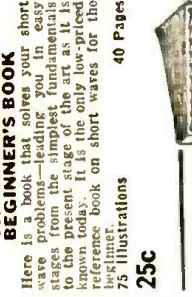

HOW TO BUILD AND OPERATE SHORT-WAVE RECEIVERS
 This is the most up-to-date book on the subject—edited and prepared by the editors of SHORT WAVE AND TELEVISION on the building and operation, not only of typical short-wave receivers, but short-wave converters as well.
 150 Illustrations
 72 Pages
50c

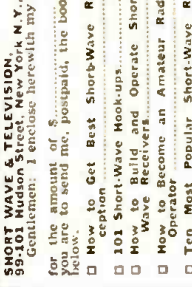

HOW TO BECOME AN AMATEUR RADIO OPERATOR
 By Lieut. Raymond A. Hays, whose experience in this line. If you intend to become a licensed amateur radio operator, if you wish to take up phone work eventually—this is the book you must get.
 150 Illustrations
 72 Pages
50c

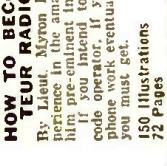

HOW TO MAKE AND WORK THEM
 The editors of SHORT WAVE AND TELEVISION describe, each receiver is fully illustrated with a complete layout, pictorial representation, photographs of the set complete, hook-up and all worth-while specifications.
 75 Illustrations, 40 Pages
25c



THE SHORT-WAVE BEGINNER'S BOOK
 Here is a book that solves your short wave problems—leading you in easy stages from the simplest fundamentals to the present stage of the most advanced known long-wave and short-wave for the beginner.
 40 Pages
25c

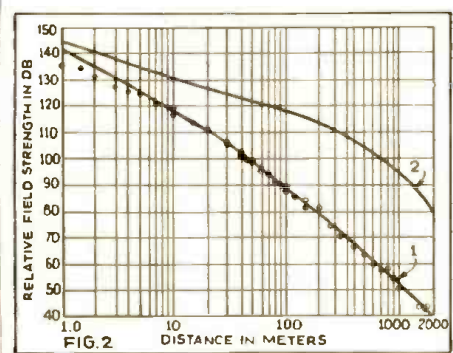

Fig. 2—Experimental points show the actual field strength. They agree with Curve 1, which applies if there is no "surface wave." Curve 2 gives calculated values of what the field strength would be if there were a surface wave.

It would attenuate rapidly with height above the earth's surface, and it would not diminish in intensity as quickly with distance as an unguided wave. Calculations from the two conflicting formulae indicate that at a distance of 1 km. (.6 mile) over Seneca Lake the received field strength, on a wave length of 2 meters, should be 44 db greater with a surface wave than without it, and that raising the receiving antenna 25 meters above the water would diminish the field 3 db with a surface wave, whereas this added antenna height would increase the field 17 db, if no surface wave were present.

To determine the variation of the field strength with distance from the transmitter the experimental arrangement shown in Figure 1 was used. The receiver was installed in a small motor boat and the transmitter towed slowly behind in a row boat, at distances from one to 150 meters. The antennas consisted of two copper rods each ten inches long placed end to end and connected by a coil. The solid circles of Figure 2 are a plot of the experimental data so obtained.

For distances greater than 150 meters it was necessary to change the experimental procedure slightly. In this case the receiver was located at the end of a pier and the transmitter carried in the motor boat. The distance from the receiver to the moving motor boat was measured by three independent methods. First, the motor boat was driven at a constant speed and in a fixed direction across the lake between two points a known distance apart. Second, the

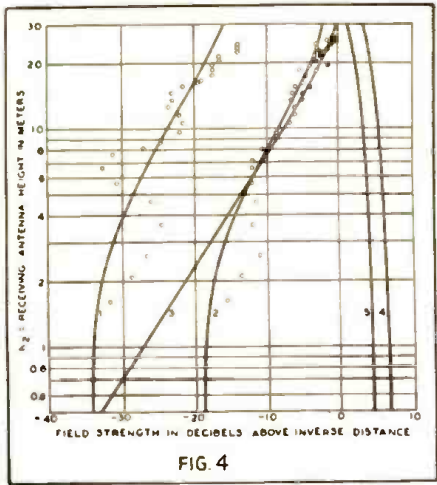

Fig. 4—Calculated and experimental values of the field strength for antennas at different heights when the transmitter was 1,800 meters distant. The circles show the experimental results.

distance to a stadia rod erected on the motor boat was measured by a transit located on the receiving pier. And third, the distance was found by determining with a sextant the angle subtended at the boat by two poles on the shore a known distance apart one at, and the other near, the receiver. The angle between the line joining the two poles and the direction to the boat was also determined by means of the transit. The open circles shown in Figure 2 represent a plot of the variation of relative field strength with distance from the transmitter as found in these experiments.

The smooth curves 1 and 2 shown in this figure were calculated with the value of the dielectric constant determined from measurements on the temperature of the water and that of the conductivity as measured by L. A. Wooten of our Chemical Laboratories on samples of the lake water. Curve 1 which is plotted from Weyl's formula is in agreement with the experimental data. As has been stated his formula contains no term corresponding to the surface wave. At distances less than 5 meters (2½ wavelengths) the experimental points lie slightly below the theoretical curve and show a tendency toward oscillation. This presumably results from the antennas not being short compared with a wavelength or from their not being exactly at the surface of the water. These oscillations may be a

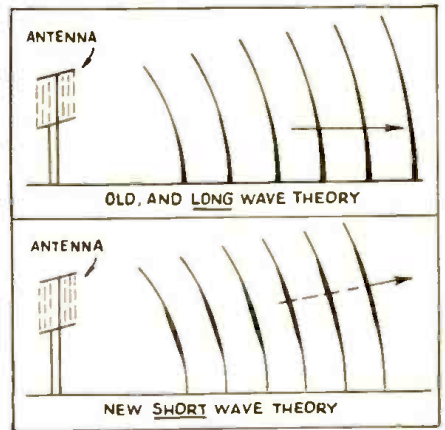

Diagram showing by thickness of line and the arrows, direction of propagation of short waves according to old and new theories.

vestige of the pronounced interference pattern that extends to greater distances with higher antennas. The experimental points lie far below curve 2, which is plotted from Sommerfeld's formula and includes the surface wave. This shows that no such surface wave was present.

To determine the variation of the field strength with the height of the antenna above the water, portable masts 25 meters high were erected at opposite sides of the lake, 1,800 meters apart. Figure 3 shows the location of the transmitter. With vertical transmitting antennas located 2.5 and 24.8 meters above the water the field strength was determined as a function of the receiving antenna height. These experimental results are compared with theory in Figure 4 which shows how the field strength varies with the height of the receiving antenna above the water, when separated 1,800 meters from the transmitter. Curves 1 and 2 give values of the field strength which would be expected from transmitting antennas 2.5 and 24.8 meters above the water, if both transmitting and receiving antennas were vertical and assuming no surface wave was present. Curve 3 shows the variation of the field strength which calculations indicate would be received with a sending antenna 24.8 meters above the water if both antennas were horizontal. Curves 4 and 5 give the magnitude of Sommerfeld's surface wave for transmitting antennas at heights of 2.5 and 24.8 meters respectively. The two sets of open circles show experimental values for sending antennas 2.5 and 24.8 meters above the water and the solid circles represent experimental data taken with

a sending antenna at an elevation of 24.8 meters when both antennas were horizontal. Again the evidence is against the existence of a surface wave. Indeed, the measured value of field strength actually decreased as the height of the receiving antenna decreased. The oscillations in the experimental points are presumably due to reflections from the cliffs and trees behind the receiving antenna.

Since we know definitely that no surface wave exists for transmission with horizontal antennas, measurements made with them may be used to calibrate the measuring equipment. This is done in Figure 4 by fitting curve (3) to the solid circles. The position of all the other smooth curves is thus fixed and they show that the absolute magnitude of the received field strength is of the order of one one-hundredth of that which would be expected from the formula which includes a surface wave.

Taken together with Rice's recent review of the work of Sommerfeld and Weyl, which has brought the two in agreement and established the fact that the prediction of a surface wave was due to a mathematical error, these tests prove conclusively that simple antennas do not generate a surface wave and that this time-honored concept must be given up, at least in the sense that radio engineers have customarily used it.

World-wide Identification List

Continued from July Issue—
Time E.S.T.

● This Station List is intended to aid DXers in identifying unknown stations. It will be run serially, in 4 or 5 Sections, the first section having already appeared in July Issue. Comments are welcomed concerning List.

B—Broadcast: C—Commercial Stations
Part Two

Freq.	Station	Mc.	Call	Type—Location—Service
15.95	RRR	C		Khbarovsk, U.S.S.R. Phones early mornings, clear speech, Russian.
15.88	FTK	C		St. Assise, France. Phones Saigon, calling "Allo, Saigon, ici Paree." Also phones So. America.
15.86	JVD	C		Nazaki, Japan. See JVF, 15.62.
15.86	CEC	C		Santiago, Chile. Phones Peru.
15.795	XOJ	C		Shanghai, China. Call given in English at beginning and end of Xmission, inverted used, clear speech rare. QRA: See XGW, 10.42.
15.74	JYT	C		Kemikawa-Cho, Japan. Call given in Japanese, irreg.
15.66	JVE	C		Nazaki, Japan. Call in English at beginning and end of Xmissions. Inverted used.
15.625	OCJ	C		Lima, Peru. Phones Chile.
15.62	JVF	C		Nazaki, Japan. Call in English at beginning and end of Xmissions. Inverted used.
15.53	HSG2	C		Bangkok, Siam. Phones Tokyo, Sked for tests, Sun, 11 p.m., Fri. 4 a.m. Rec'd direct from Bangkok.
15.45	IUG	C		Addis Abeba, Ethiopia. Call heard at beginning and irreg. thru Xmission. "Pronto Radio Collano, da Addis Abeba."
15.44	XEBMB-XEBL	C		Mazatlan, Sinaloa, Mexico. Relays both calls given together. QRA, P. O. Box 50, Mazatlan.
15.37	HASS	B		Budapest, Hungary. See IAT4, 9.125 mc.
15.29	LRU	B		Buenos Aires, Argentina English annts. at beginning and end of Xmissions. Special selection begins and ends broadcast.
15.252	RIM	C		Tashkent, U.S.S.R. Calls Moscow—"Allo, Moskva," clear speech always used, heard ams.
15.23	OLR5AB	B		Praha, Czechoslovakia. See OLR6A, 21.45 mc.
15.22	PCJ	B		Hilversum, Holland. See PCJ, 9.59 mc.
15.19	ZBW4	B		Hongkong, China. See ZBW3, 9.525 mc.
15.16	ZJK	B		Nazaki, Japan. See JZI, 9.535 mc.
15.15	YDC	B		Bandoeng, Java. 3 kw. Announcement at beginning of Xmission and afterwards at changes of program, NIROM is mentioned, together with name of city program originates from. Signs off with "End of a Perfect Day." QRA: NIROM, Koningsplein West 3, Batavia C., Java.
15.12	HVJ	B		Vatican City, Rome, Italy. Ann't—"Stazione Radio HVJ, Radio Vaticano." Tick-tock of a metronome heard for about 5

AMERICA'S MOST POPULAR RADIO BOOKS

We herewith present a selected collection of recent important radio books. We have selected these volumes because they represent the foremost radio books of their kind in print today. We publish no catalog. Order direct from this page. Prompt shipments will be made to you. Remit by money order or certified check. Register all letters containing cash.

SHORT WAVES, 284 pages, 258 illus. \$.69	FUNDAMENTALS OF RADIO, 426 pages, illustrated. Prepaid. \$3.46
PRACTICAL TELEVISION, 223 pages, 127 illus. \$3.69	ELECTRICITY AT HIGH PRESSURES AND FREQUENCIES, 248 pages, 141 illus. Prepaid. \$1.89
ELEMENTS OF RADIO COMMUNICATION, 286 pages, 241 illus. \$2.98	RADIO CONSTRUCTION AND REPAIRING, 434 pages, illustrated. \$2.50
RADIO PHYSICS COURSE, 992 pages, 510 illus. \$4.00	THEORY OF VACUUM TUBE CIRCUITS, 226 pages, 226 illus. \$3.00
THE RADIO AMATEUR'S HANDBOOK, 448 pages, 126 illus. \$1.97	PRINCIPLES OF RADIO COMMUNICATION, 998 pages, profusely illus. \$7.35
RADIO THEORY AND OPERATING, 1,000 pages; over 800 illus. \$4.38	RADIO ENGINEERING, 688 pages, 418 illus. \$5.00
MODERN RADIO ESSENTIALS, over 200 pages, and over 100 illus. \$1.95	EXPERIMENTAL RADIO ENGINEERING, 346 pages, 250 illus. \$3.46
FOUNDATIONS OF RADIO, 246 pages, 145 illus. \$2.47	RADIO OPERATING QUESTIONS AND ANSWERS, 427 pages, 106 illus. \$2.50
PHOTOCELLS AND THEIR APPLICATION, 332 pages, 180 illus. \$2.88	OFFICIAL RADIO SERVICE HANDBOOK, over 1,000 pages, over 1,000 illus. Prepaid. \$3.95
ELECTRONICS, 134 pages, 45 illus. \$1.95	OFFICIAL SHORT-WAVE RADIO MANUAL, 240 pages, many illustrations. Vol. 1 (1934) Prepaid. \$2.00
SHORT WAVE RADIO HANDBOOK, 128 pages, 150 illus. \$1.00	Vol. 2 (1935) Prepaid. \$2.50
PRINCIPLES OF RADIO, 478 pages, 308 illus. \$3.46	OFFICIAL RADIO SERVICE MANUAL, Volume 4, 2,000 illus., over 400 pages. Prepaid. \$3.00
EXPERIMENTAL RADIO, 256 pages, 168 illus. Prepaid. \$2.69	OFFICIAL RADIO SERVICE MANUAL, Volume 5, over 3,000 illus., over 1,000 pages. Prepaid. \$5.86
MODERN RADIO SERVICING, 1300 pages, over 700 illus. \$4.00	OFFICIAL RADIO SERVICE MANUAL, Volume 6, over 1,200 pages, over 2,500 illus. Prepaid. \$7.00
DRAKE'S CYCLOPEDIA OF RADIO AND ELECTRONICS, 1050 pages, 1178 illus. \$4.88	

15 HANDY—POCKET-SIZE RADIO BOOKS

Here are 15 up-to-date books on radio and air conditioning. Modern in every sense. ALL BOOKS UNIFORM (from 64 to 72 pages; 50 to 120 illustrations. All books written by well-known authors. Order by Number.

- 1 RADIO SET ANALYZERS
- 2 MODERN RADIO VACUUM TUBES
- 3 THE SUPERHETERODYNE BOOK
- 4 MODERN RADIO HOOKUPS, By R. D. Washburne
- 5 HOW TO BECOME A RADIO SERVICE MAN
- 6 BRINGING ELECTRIC (RADIO) SETS UP TO DATE, by C. E. Denton
- 7 RADIO KINKS & WRINKLES (for Experimenters)
- 8 RADIO QUESTIONS & ANSWERS, by R. D. Washburne
- 9 AUTOMOBILE RADIO & SERVICING
- 10 HOME RECORDING AND ALL ABOUT IT, by Geo. J. Saliba
- 11 POINT-TO-POINT RESISTANCE MEASUREMENTS by C. E. Denton
- 12 PUBLIC ADDRESS INSTALLATION AND SERVICE
- 13 ABC OF AIR CONDITIONING, by Paul D. Harrigan
- 14 POCKET RADIO GUIDE, by N. H. Lessen.
- 15 ABC OF REFRIGERATION PRICE PREPAID EACH BOOK 45c

HOW TO ORDER

No. C.O.D. orders. Our prices are net, as shown. Some of the books sent prepaid (in U.S. only). Those that are not thus listed are shipped collect if sufficient postage is not sent. Add 7% of price for postage.

RADIO PUBLICATIONS, 97 HUDSON ST., NEW YORK, N. Y.

CLASSIFIED

Advertisements are inserted at 5c per word to strictly amateurs, or 10c a word to manufacturers or dealers. Each word in a name and address is counted. Cash should accompany all orders. Copy for the September issue should reach us not later than July 6.

<p>AGENTS WANTED</p> <p>GOLD LETTERS FOR STORE Windows. 500% Profit. Free Samples. Metallite Co., 433-R N. Clark, Chicago.</p> <p>"HAM" OFFERS AND WANTS</p> <p>WANTED: AMATEUR IN NEW YORK CITY or vicinity with recording equipment to make high quality recordings on acetate. 16 inch 33 1/3 R.P.M. of radio broadcast music of Guy Lombardo and Royal Canadians; at nominal cost. Whitney Freeland, 3103 N.E. 15 Ave., Portland, Oregon.</p> <p>EILEN SIX, HANDSWITCH NEW. Ready to operate. \$18.00. William Diehl, 340 Lincoln Avenue, Scranton, Pennsylvania.</p> <p>WANTED GOOD USED MASTER Teleplex. Stanley Stone, Sussex, Wisc.</p> <p>SELL FIVE TUBE SUPERHET A-1 parts, performance. Handsread, heat oscillator, power. For ham. SWL Complete—\$20. W9VZ1, West Allis, Wisconsin.</p>	<p>MISCELLANEOUS</p> <p>WE ORIGINALLY HAD FIVE thousand Stoupan Compasses for which the U.S. Government paid over \$30.00 each. We sold all but a very few. We cannot obtain more to sell at three times our present price. Send in your order before they are all sold at \$4.50 each, postage paid. Gold Shield Products, Room 14, Eleventh floor, 99 Hudson St., New York City.</p> <p>COIL, INDUCTANCE CHARTS—complete set for any size coil; accurate; \$2.15 prepaid. Slide Rules—4 inch circular type \$2.00; 8" dia., 20" scale, \$5.00 prepaid. Dataprint Co., Box 322, Ramsey, N.J.</p> <p>PATENT ATTORNEYS</p> <p>INVENTORS. ALL PATENT AND trademark cases submitted given personal attention by members of the firm. Form "Evidence of Conception" and instructions free. Lancaster, Allyn & Tommel, 436 Haven Building, Washington, D. C.</p> <p>QSL—CARDS—SWL</p> <p>100 NEAT SWL CARDS PRINTED with your name and address sent post-paid for \$1. Bundle of samples and RST chart for five cent stamp. WVBEP, 16 Stockbridge, Lowell, Mass.</p>	<p>SHORT WAVE LISTENER'S DIRECTORY. New Issue 15c. (one year list-ricity in SWL Directory with 8 1/2 "x15" certificate. 25c. SWL-Directory, Sta. H, Box 116, Toledo, Ohio.)</p> <p>SENSATIONAL, NEW DESIGNED reply Getting Short Wave Listener's and Amateur QSL cards. Samples (Stamps). W-8-E-S-N, 1827 Conco, Toledo, Ohio.</p> <p>QSL SWL CARDS, NEAT, ATTRACTIVE, reasonably priced, samples free. Miller, Printer, Ambler, Pa.</p> <p>SHORT WAVE RECEIVERS</p> <p>SELL: NATIONAL ACSW3s \$9.00, ACSW5s \$10.00. Skyriders \$17.50. Browning 35 \$25.00. Sky Chiefs \$29.00. Super Skyriders \$29.00. Silver 5BXs \$31.00. ACW-136s \$39.00. all other sets. Robert Henry, Butler, Missouri.</p> <p>MAKE CRYSTAL SETS WITH H Loudspeaker Volume, also Pocket Radios. Information. P. Boer, Santa Ana, Calif.</p> <p>WIND ELECTRIC PLANTS</p> <p>BUILD WIND LIGHT PLANT from automobile generator. Plans 10c. 50 other generator changes. LeJay Manufacturing, 1417 Lake, Minneapolis, Minn.</p>
---	--	--

More and More Radio Men Are Reading RADIO-CRAFT!

RADIO-CRAFT is devoted to all phases of radio, to servicing, and to the advanced set builder. Brings you shortcuts that show you the way out of difficult problems. Latest Radio Equipment is illustrated and described. Then there's the International Radio Review, Service Data Sheets, New Tubes, Radio Month in Review, Set Construction, Television, operating Notes, and other interesting departments. Edited by Hugo Gernsback. Over 175 Illustrations in each issue.

8 Months \$1 for 1

RADIO-CRAFT, 99 C Hudson Street, New York, N. Y.

NOW THEY CAN BE BOUGHT! SEE PAGE 192 FOR DETAILS ON TWO BOOKS ON SHORT WAVES AND TELEVISION

Please mention SHORT WAVE & TELEVISION when writing advertisers

the AMPERITE VELOCITY

with NEW DESK STAND

Ideal for desk, pulpit, footlights, banquets. Leaf spring suspension acts as shock absorber. STAND ONLY . . . LIST \$4.00 NAME PLATE with call letters . . . LIST \$2.00

MICROPHONES: Model RBHn (High Imped.) or RBMa (200 ohms) with cable connector & switch . . . LIST \$42.00 Models RBSn, RSHn, with switch only . . . LIST \$32.00

NEW "HAM MIKE"

No Peaks! No Splashing! Real Broadcast Quality! RF Choke Circuit included in microphone. Output—68 db. Operates directly into grid. MODEL HAM (High Imped.) or MODEL HAL (200 ohms) . . . Gunmetal. LIST \$22.00. Chrome LIST \$23.00. Price includes Ham Desk Stand. Call Letters, and 6 feet of cable.

MODEL RAL \$22.00 LIST

A popular Amperite Velocity of very high excellence. Used for both speech and music. No peaks. Flat response over audible range. Output—68 db. Triple shielded. Shock absorber, swivel bracket. MODEL RAL (200 ohms); or MODEL RAH (2000 ohms) high impedance . . .

FREE: Window Decal & Window Display

AMPERITE Co. 561 BROADWAY, N. Y.

AMPERITE Velocity MICROPHONE

KENYON



EFFICIENT

RELIABLE

MODERN

KEN-O-TAP
The Practical Solution to the Modulation Problem

KEN-O-DRIVE
The Modern Answer to Critical Driver Operation

KEN-O-DYNE
The Precision Method of Matching Output Tubes to Speakers

KEN-O-LINE
The Efficient Coupling Device from Universal Line

Ask Your Dealer For Our 16 Page "T" Line Catalog Which Contains A Large Selection Of Modern Audio Circuits.

Kenyon Transformer Co., Inc.
840 Barry St. New York, N. Y.
Export Dept. Cable Address: 25 Warren St. Simontronic, N. Y.

- minutes before broadcast. Opens BC with Bells of St. Peter. Begins and ends with phrase "Laudetur Jesus Christus." Uses different language each day of week.
- 15.06 WNC C—Ifialeah, Florida. Calls and phones the following: in daytime, all on 14,485 mc. YSJ, HRL5, TIU, YNA, HFF, HRF, TGF and YSJ on 13.41 mc.
 - 15.04 RKI C—Moscow, U.S.S.R. Calls various Soviet stations, using Russian in clear speech. Man or woman calls.
 - 14.935PSE C—Rio de Janeiro, Brazil. Phones South America and New York. Heard calling "Hello, New York. This is PSE calling." Contacts in clear speech, then uses inverted.
 - 14.92 LZA B—Sofia, Bulgaria. Slogan: "Radio Sofia." Opens, closes program with native compositions. Male, female announcers used.
 - 14.79 ROU C—Omsk, Siberia, U.S.S.R. Phones Moscow mornings, "Allo Moskva." Speaks Russian, clear speech always used. Also phones other Soviet stations.
 - 14.73 IQA C—Rome, Italy. Phones Asmara, mornings, saying "Pronto Asmara da Roma." Clear speech heard throughout xmission, using Italian.
 - 14.653GBL C—Rugby, England. Phones JVIL, Tokyo, early a.m.s, calling "Hello, JVIL, hello Tokyo, GBL calling." Contacts in clear speech, switches to inverted.
 - 14.60 JVH C—Nagasaki, Japan. Phones London, giving call in English at beginning and end of xmission.
 - 14.535HBJ C—Geneva Switzerland. Occasionally relays "League of Nations" programs to New York, calling at beginning "Hello, New York, HBJ, Geneva, calling." Usually on week end afternoons.
 - 14.485IBS C—Rome, Italy. Call "Radio San Paolo," used at beginning, when calling Italian Colonial Stations and irregularly throughout.
 - 13.82 SUZ C—Cairo, Egypt. Calls "Hello, London, SUZ, Cairo calling you." Contacts in clear, switches to inverted speech. Phones GBB, 13.58 mc.
 - 13.635SPW B—Warsaw, Poland. Announces in English, "The Polish Short Wave Station SPW."
 - 13.58 GBB C—Rugby, England. Calls SUZ, "Hello, Cairo, London is calling you." Contacts in clear, then switches to inverted for commercial traffic. Daily 11 a.m.
 - 13.38 IDU C—Asmara, Eritrea. Calls Rome, Addis Abeba, and Mogadiscio—"Pronto—da Radio Asmara." Italian, clear speech used. Man or woman may talk.
 - 13.34 VLZ C—Sydney, Australia. Call VK2ME used on experimental broadcasts, especially to Shenectady. VLK used in phone work with London; VLZ used with Wellington, New Zealand and Bandoeng, Java. Call given at beginning and end of xmission. Inverted used when phoning commercial.
 - 13.30 ZMBJ C—"SS Awatea", N. Z. Phones Australia, gives call.
 - 13.30 JFZC C—NYK Liner "Chichibu Maru." See JFZC, 17.70 mc.
 - 13.22 IRJ C—Rome, Italy. Phones Cairo daytime, calling "Pronto Cairo, Iqua Roma." Plays music between calls. Phones clear speech. Occasionally phones Tokyo.
 - 12.865IAC C—Coltano, Italy. Calls Italian ships and Italian Colonies. "Pronto—da Coltano" heard when calling.
 - 12.83 CNR C—Rabat, Morocco. Rarely used on special broadcasts. Usually heard phoning; side-band secrecy; voice heard poorly on either edge of carrier wave.
 - 12.795IAC C—Coltano, Italy. See 12.865 mc.
 - 12.30 CB615 B—Santiago, Chile. Slogan "Radio Service."
 - 12.235TFJ B—Reykjavik, Iceland. Uses slogan "The Icelandic Broadcasting Station." Gives location.
 - 12.215TYA C—Paris, France. Phones TPZ, Algiers, using side-band secrecy.
 - 12.12 TPZ C—Alger, Algeria. Phones TYA, using side-band secrecy.
 - 12.00 RNE B—Moscow, U.S.S.R. Announces "This is Moscow calling, RNE, on 25 Meters." Plays "Internationale" at beginning and close of xmission. Occasionally phones Siberia in clear speech.
 - 11.99 FZS C—Saigon, Indo-China. Phones Paris mornings, calling "Allo, Parez, ici Saigon," in clear speech. French.
 - 11.956IUC C—Addis Abeba, Ethiopia. Calls Rome, Italian colonies, "Pronto—da Addis Abeba."
 - 11.94 FTA C—St. Assise, France. Calls Saigon early a.m.s, irregularly "Allo, Saigon, ici Parez." French used.

Index to Advertisers

A	
Ace Radio Laboratories.....	190, 205
Allied Engineering Institute.....	202
Allied Radio Corp.....	198
Amperite Company.....	208
Astatic Microphone Laboratory, Inc.....	193
B	
Bliley Electric Co.....	198
Brach, L. S., Mfg. Corp.....	199
C	
Cameradio Co.....	201
Candler System Co.....	196
Cannon, C. F., Company.....	194
Classified Advertisements.....	207
Cornell-Dubilier Corp.....	200
Cornish Wire Co.....	203
Coyne Electrical School.....	197
D	
Dataprint Company.....	202
Dodge's Institute.....	197
E	
Eilen Radio Laboratories.....	189
G	
Gadgets Magazine.....	200
Gold Shield Products Co.....	194
Goldentone Radio Co.....	198
H	
Hallcrafters, Inc.....	Back Cover
Hammarlund Manufacturing Co., Inc.....	203
Harrison Radio Company.....	192
I	
Instructograph Company.....	197
J	
Jarnak, Paul.....	190
K	
Kenyon Transformer Co., Inc.....	208
Korrol Radio Products Co.....	199
M	
McElroy, T. R.....	196
Midland Television, Inc.....	197
Milady.....	205
N	
National Company, Inc.....	Inside Back Cover
National Radio Institute.....	161
National Schools.....	197
O	
Onan, D. W., & Sons.....	205
R	
Radio & Television Institute.....	197
Radio Constructors Laboratories.....	191
Radio Craft.....	207
Radio Publications.....	204, 207
Radio Training Assn. of America.....	197
Raytheon Production Corporation.....	195
RCA Institute, Inc.....	197
S	
Sargent, E. M., Co.....	193
Short Wave Coil Book.....	204
Short Wave League.....	202
Solar Mfg. Corp.....	190
Standard Transformer Corporation.....	205
Superior Instruments Company.....	199
T	
Teleplex Co.....	196
Triplet Electrical Instrument Co.....	203
Tri-State College.....	196
Try-Mo Radio Co., Inc.....	194
U	
Ultra High Frequency Products Co.....	Inside Front Cover
United Radio Company.....	194
Universal Microphone Co., Ltd.....	203
Utah Radio Products Co.....	201
W	
Wellworth Trading Company.....	198, 202
Wholesale Radio Service Co., Inc.....	193

(While every precaution is taken to insure accuracy, we cannot guarantee against the possibility of an occasional change or omission in the preparation of this index.)

Please mention SHORT WAVE & TELEVISION when writing advertisers

KABLE BROS. CO., PRINTERS

PERFORMANCE PLUS:



Built for *extra* performance, the twelve tube NC-100 Receiver includes every refinement for difficult short wave work. Among its many unusual features is the unique Movable Coil Tuning Unit which combines the high electrical efficiency of plug-in coils with the convenience of the coil switch. Tuning from 540 KC to 30 MC is covered in five ranges, so that stations are well spread out. Each of the fifteen high frequency coils is shielded in its own compartment of cast aluminum. The turn of a knob on the front panel brings the desired range into position and plugs it in. Idle coils are isolated, leads are short, and calibration is exact. There are no dead spots in the NC-100 Receiver.

Fully worthy of the advanced performance of the Tuning Unit are other details of the superheterodyne circuit. Thorough use of low loss insulation and of air-dielectric condensers, together with carefully designed high-Q coils, results in exceptionally high signal-to-noise ratio and high usable sensitivity. The advanced design of the (optional) Crystal Filter provides unusual effectiveness when QRM is severe.

Panel controls are complete, and include separate switches for B-supply, Filaments, CW Oscillator, and AVC; as well as dials for Audio Gain, RF Gain, Tone Control, and CW Oscillator Tuning. Crystal Filter controls include Phasing and Selectivity. The precision Micrometer Dial, direct reading to one part in five hundred, provides exceptional ease of tuning together with great accuracy in logging.

These are but a few of the features that combine to make the NC-100's performance so outstanding, and its low price so remarkable. An illustrated folder will be mailed on request if you mention Dept. S-8.

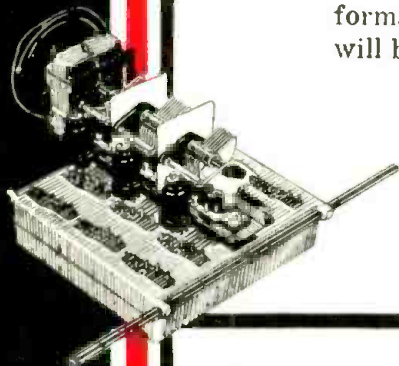

NATIONAL COMPANY, INC., MALDEN, MASS.

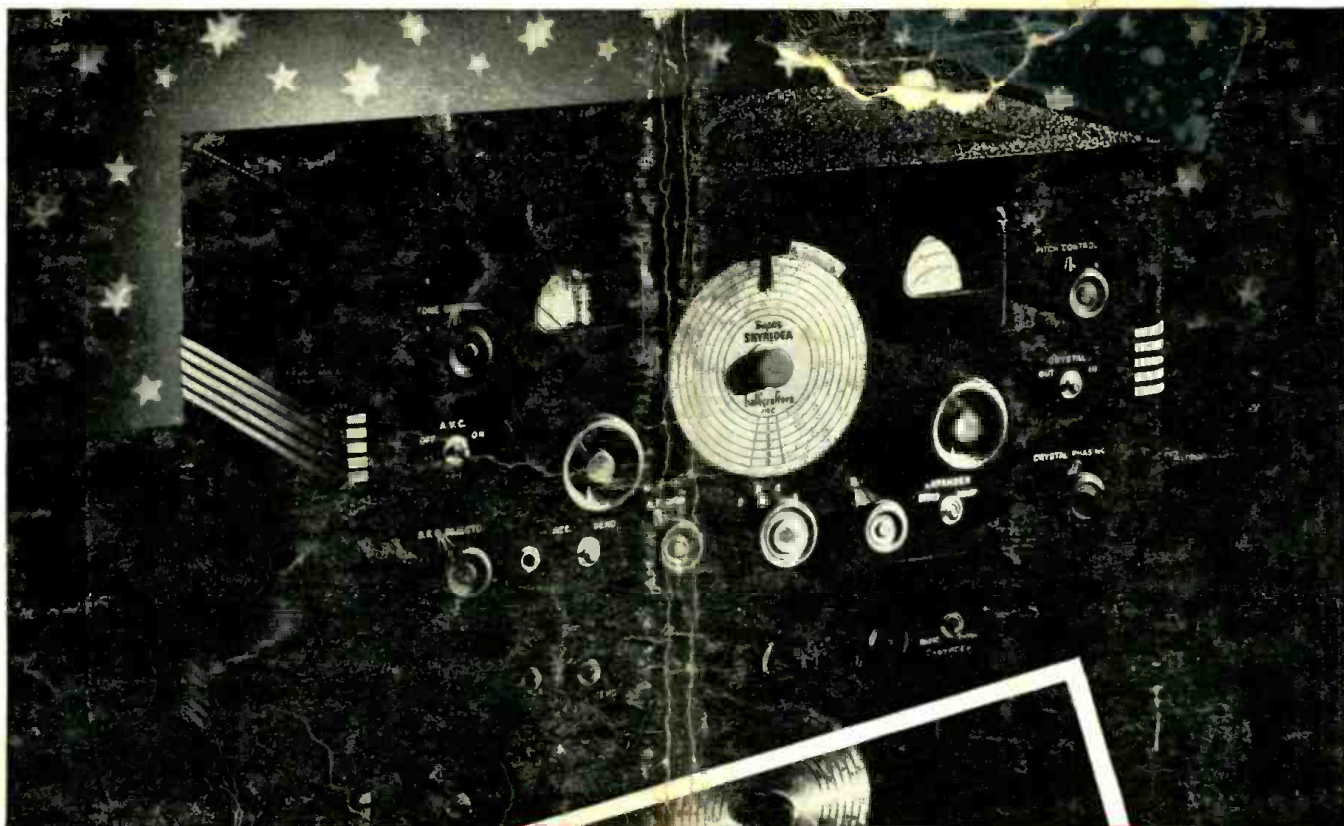

WHAT IS A *Communications Receiver?*

It's more than just a "short wave" receiver! A communications receiver is primarily designed for efficient "high frequency" reception—a rugged, "scientific", precision-built job designed to operate at high efficiency under adverse conditions and in emergencies.

Who can design such receivers? Obviously the engineers who use them as their own hobby—and *know* what they should be.

Such men predominate in the Hallicrafters' organization. Here is a group of engineers who have been actively interested in radio since the days of spark transmitters and crystal detectors.

Today they are building fine communications receivers, putting into them all the enthusiasm and craftsmanship they lavish upon their personal equipment.

Because of their extensive, intimate experience with radio problems, and because of their unequalled research and experimental equipment, the Hallicrafters can build a receiver like the New 1938 Super Sky Rider, providing this unexcelled short wave performance but also with complete coverage from 5 to 550 Meters, with more than ample sensitivity for communications work, *plus* wide range variable selectivity that offers true high fidelity, and marvelous tone quality for broadcast reception.

Hallicrafters receivers are fully licensed, thus placing at the disposal of the Hallicrafters staff the developments of a whole generation of leading radio engineers.

When you purchase a Hallicrafters receiver you are not only buying a fine precision-built instrument, but the product of a group of engineers whose pride and life work are represented in that receiver.

ASK YOUR DEALER ABOUT THE HALLICRAFTERS TIME PAYMENT PLAN

**SEND FOR ILLUSTRATED BOOKLET
COMPLETELY DESCRIBING THE
NEW 1938 SUPER SKY RIDER**

the hallicrafters inc.

2601 Indiana Ave., Chicago, U. S. A.
Cable Address, "Hallicraft" Chicago

"AMERICA'S LEADING MANUFACTURER OF COMMUNICATIONS RECEIVERS"